











Hoval Indoor Climate Systems TopVent®

Recirculation units and supply air units with efficient air distribution
for heating and cooling with central heat and cold generation
TopVent® TH | TC | THC | MH | MC | MHC

Design handbook

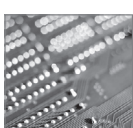

Hoval

	<p>Hoval Indoor Climate Systems 3</p> <p>Efficient. Flexible. Reliable.</p>	A
	<p>TopVent® TH 7</p> <p>Recirculation units for heating spaces up to 25 m in height with central heat supply</p>	B
	<p>TopVent® TC 19</p> <p>Recirculation units for heating and cooling spaces up to 25 m in height with central heat and cold supply (2-pipe-system)</p>	C
	<p>TopVent® THC 33</p> <p>Recirculation units for heating and cooling spaces up to 25 m in height with central heat and cold supply (4-pipe-system)</p>	D
	<p>TopVent® MH 45</p> <p>Supply air units for ventilating and heating spaces up to 25 m in height with central heat supply</p>	E
	<p>TopVent® MC 57</p> <p>Supply air units for ventilating, heating and cooling spaces up to 25 m in height with central heat and cold supply (2-pipe-system)</p>	F
	<p>TopVent® MHC 71</p> <p>Supply air units for ventilating, heating and cooling spaces up to 25 m in height with central heat and cold supply (4-pipe-system)</p>	G
	<p>Options 85</p>	H
	<p>Transport and installation 99</p>	I
	<p>System design 109</p>	J
	<p>Control systems</p> <p>Hoval TopTronic® C</p> <p>→ see 'Control Systems for Hoval Indoor Climate Systems' manual</p>	



Hoval Indoor Climate Systems

Efficient. Flexible. Reliable.

A





Efficient. Flexible. Reliable.

Hoval indoor climate systems are decentralised systems for heating, cooling and ventilating halls for industrial, commercial and leisure applications. The systems have a modular structure. One system comprises several ventilation units which are spread around the room. These units are equipped with reversible heat pumps and gas-fired appliances for decentralised heat and cold generation, or they heat and cool with a connection to a central energy supply. Tailored control systems complete the system and ensure the effective combination and optimal use of all resources.

Diverse range of units ensures flexibility

Different types of ventilation units can be combined to create the perfect system for the project in question:

- RoofVent® supply and extract air handling units
- TopVent® supply air units
- TopVent® recirculation units

The number of supply and extract air handling units depends on how much fresh air is required in order to create a comfortable atmosphere for people in the building. Recirculation units cover additional heat or cool demand as required. A broad range of unit types and sizes with heating and cooling coils in various output levels means that the overall output of the system can be scaled to whatever level is required.

Specially designed unit versions are also available for halls with particularly humid or oily extract air.

Furthermore, there is a range of units available which have been expressly developed for very specific purposes. ProcessVent units, for example, are coupled with extract air purification systems in industrial halls and recover heat from process air.

Draught-free air distribution

A key feature of Hoval indoor climate units is the patented vortex air distributor, known as the Air-Injector. It is controlled automatically and changes the blowing angle of the air continuously between vertical and horizontal. The highly efficient air supply system has many advantages:

- It provides a high level of comfort during heating and cooling. No draughts develop in the hall.
- The efficient and even air distribution ensures that the indoor climate units cover a large area.
- The Air-Injector keeps the temperature stratification in the room low, thus minimising heat loss through the roof.

Control with specialist expertise

The TopTronic® C control system, which was specifically developed for Hoval indoor climate systems, regulates the separate units individually and controls them based on zones. This enables optimal adjustment to the local requirements of the different usage areas in the building. The patented control algorithm optimises energy use and ensures maximum comfort and hygiene levels. Clear interfaces make it easy to connect the system to the building management system.

Simpler control systems are also available for units that are only used for supply air or air recirculation.

Competent and reliable

Hoval will support you and provide expert knowledge throughout all project phases. You can rely on comprehensive technical advice when it comes to planning Hoval indoor climate systems and on the skills of the Hoval technicians during the installation, commissioning and maintenance of the system.

System with decentralised heat and cold generation with heat pump

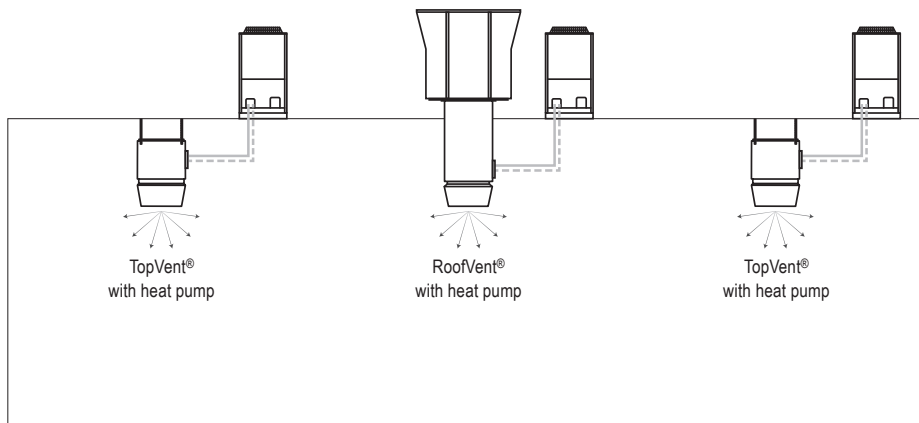

System with central heat and cold generation

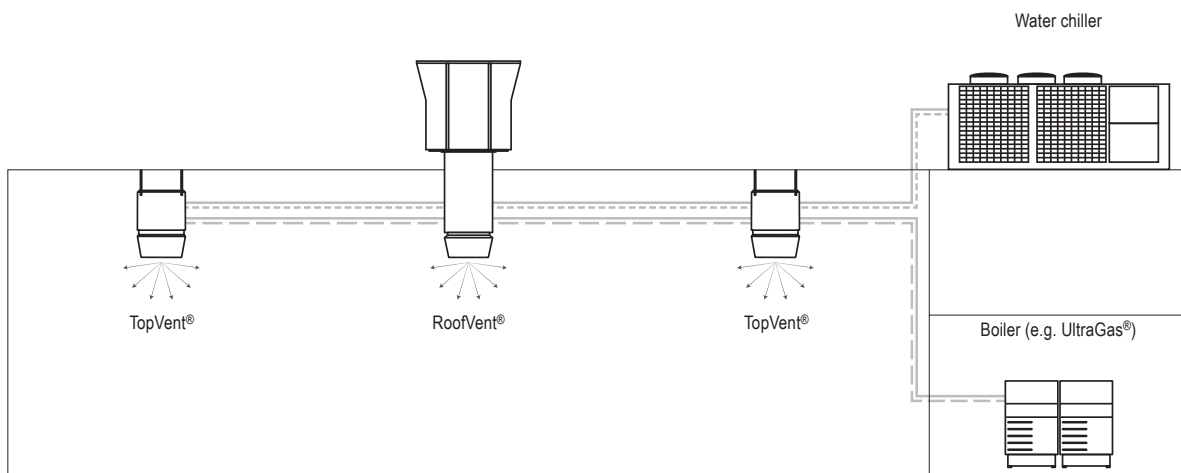

System with decentralised, gas-fired heat generation

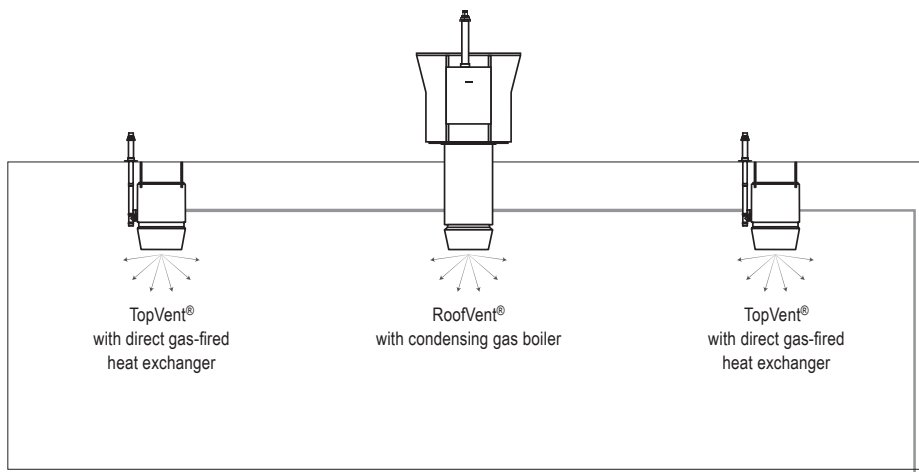



TopVent® TH

Recirculation units for heating spaces up to 25 m in height with central heat supply

1 Use8
2 Construction and operation8
3 Technical data11
4 Specification texts14

B

1 Use

1.1 Intended use

TopVent® TH units are recirculation units for heating spaces up to 25 m in height with central heat supply. They have the following functions:

- Heating (with connection to a hot water supply)
- Recirculation operation
- Air distribution and destratification with adjustable Air-Injector
- Air filtration (option)

TopVent® TH units comply with all the requirements of the Ecodesign Directive 2009/125/EC relating to environmentally friendly design of energy-related products. It is a system of the 'fan coil unit' type.

The Hoval TopTronic® C integrated control system ensures energy-efficient, demand-based operation of Hoval indoor climate systems.

Intended use also includes compliance with the operating instructions. Any usage over and above this use is considered to be not as intended. The manufacturer can accept no liability for damage resulting from improper use.

1.2 User group

The units are only allowed to be installed, operated and maintained by authorised and instructed personnel who are well acquainted with the units and are informed about possible dangers.

The operating instructions are for operating engineers as well as specialists in building, heating and ventilation technology.

2 Construction and operation

2.1 Construction

The TopVent® TH unit consists of the following components:

- Fan unit:
Axial fan with energy-saving EC motor, maintenance-free and infinitely variable
- Heating section:
Contains the heating coil for heating the supply air with hot water
- Air-Injector:
The Air-Injector is a patented, infinitely variable vortex air distributor for the draught-free introduction of air into the hall under changing operating conditions.

As part of the TopTronic® C control system, the unit control box is an integral component.

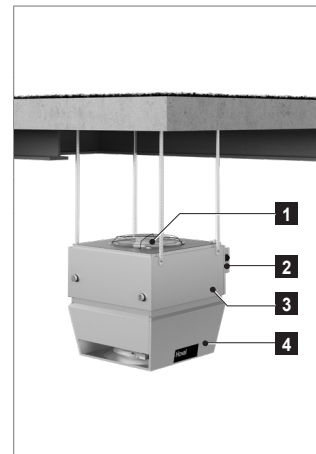

- | | |
|---|------------------|
| 1 | Fan unit |
| 2 | Unit control box |
| 3 | Heating section |
| 4 | Air-Injector |

Fig. B1: TopVent® TH components

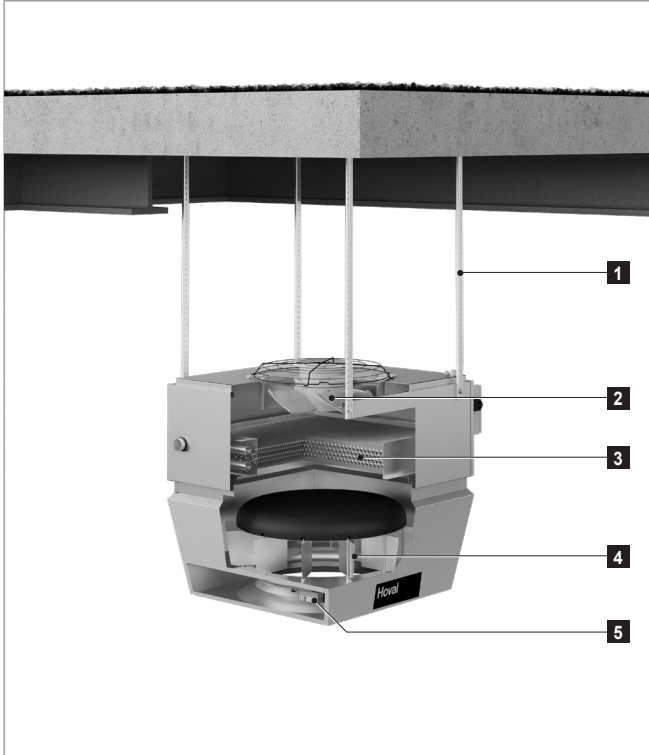

- 1 Suspension set
- 2 Fan
- 3 Heating coil
- 4 Air-Injector
- 5 Actuator Air-Injector

Fig. B2: TopVent® TH construction

2.2 Function diagram

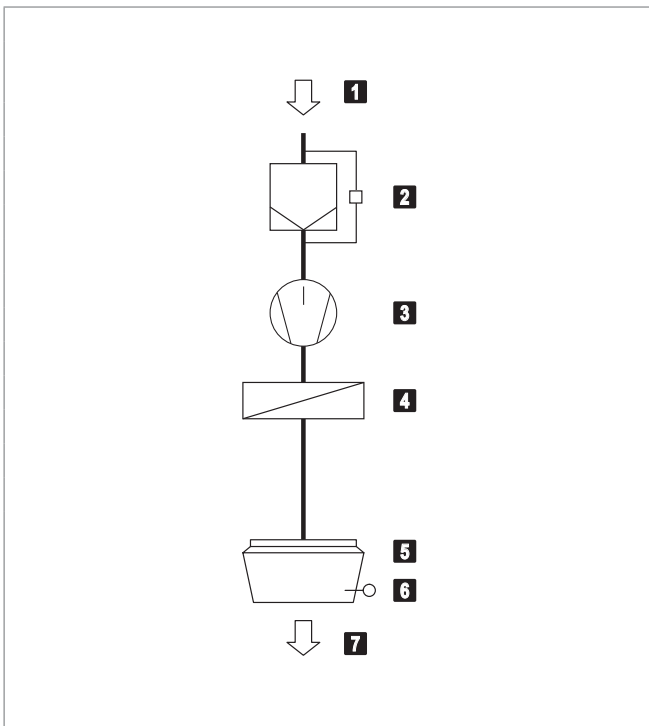

- 1 Extract air
- 2 Air filter with differential pressure switch (option)
- 3 Fan
- 4 Heating coil
- 5 Air-Injector with actuator
- 6 Supply air temperature sensor
- 7 Supply air

Fig. B3: TopVent® TH function diagram

2.3 Operating modes

The TopVent® TH has the following operating modes:

- Recirculation
- Recirculation speed 1
- Standby

The TopTronic® C control system regulates these operating modes automatically for each control zone in accordance with the specifications in the calendar.

The following points also apply:

- The operating mode of a control zone can be switched over manually.
- Each TopVent® TH unit can operate individually in a local operating mode: Off, Recirculation, Recirculation speed 1.

Code	Operating mode	Description
REC	Recirculation On/off-operation: if heating is required, the unit draws in room air, heats it and blows the warm air back into the room. The room temperature set value day is active.	Fan speed 1/2 ¹⁾ Heating on ¹⁾ Depending on heat demand
DES	■ Destratification: To avoid heat build-up under the ceiling, it may be appropriate to switch on the fan when there is no heat demand (either in permanent operation or in on/off operation depending on the temperature stratification, as desired).	Fan speed 2 Heating off
REC1	Recirculation speed 1 The same as REC, but the unit operates only at speed 1 (low air flow rate)	Fan speed 1 ¹⁾ Heating on ¹⁾ Depending on heat demand
DES	■ Destratification: The same as for REC, but the unit operates only at speed 1	Fan speed 1 Heating off
ST	Standby The unit is ready for operation. The following operating modes are activated if required:	
CPR	■ Cooling protection: If the room temperature drops below the set value for cooling protection, the unit heats up the room in recirculation operation.	Fan speed 2 Heating on
L_OFF	Off (local operating mode) The unit is switched off.	Fan off Heating off
–	Forced heating The unit draws in room air, warms it and blows it back into the room. Forced heating is activated by connecting the unit to a power supply (only if there is no bus connection to the zone controller). For example, it is suitable for heating the hall before taking the control system into operation or if the controller fails during the heating period.	Fan speed 2 Heating on

Table B1: TopVent® TH operating modes

3 Technical data

3.1 Type code

TH - 6 A - ...	
Unit type	TopVent® TH
Unit size	6 or 9
Heating section	A with coil type A B with coil type B C with coil type C
Further options	

Table B2: TopVent® TH type code

3.2 Application limits

Extract air temperature	max.	°C	50
Supply air temperature	max.	°C	60
Temperature of the heating medium ¹⁾	max.	°C	90
Pressure of the heating medium	max.	kPa	800
The units cannot be used in:			
<ul style="list-style-type: none"> ■ Damp locations ■ Places with a corrosive or aggressive environment ■ Spaces with a large amount of dust ■ Areas where there is danger of explosion 			
¹⁾ Design for higher temperatures on request			

Table B3: TopVent® TH application limits

3.3 Electrical connection

Unit type		TH-6	TH-9
Supply voltage	V AC	3 × 400	3 × 400
Permitted voltage tolerance	%	± 5	± 5
Frequency	Hz	50	50
Connected load	kW	1.5	2.1
Current consumption max.	A	2.9	4.0
Series fuse	A	13	13
Protection rating	-	IP 54	IP 54

Table B4: TopVent® TH electrical connection

3.4 Air flow rate

Unit type		TH-6	TH-9
Nominal air flow rate	m³/h	6000	9000
Floor area covered	m²	537	946

Table B5: TopVent® TH air flow rate

3.5 Sound level

Unit type		TH-6C	TH-9C
Sound pressure level (at a distance of 5 m) ¹⁾	dB(A)	55	58
Total sound power level	dB(A)	77	80
Octave sound power level	63 Hz	dB	55
	125 Hz	dB	60
	250 Hz	dB	65
	500 Hz	dB	70
	1000 Hz	dB	74
	2000 Hz	dB	70
	4000 Hz	dB	64
8000 Hz	dB	56	

¹⁾ with a hemispherical radiation pattern in a low-reflection room

Table B6: TopVent® TH sound level

3.6 Heat output

Heating medium temperature			80/60 °C					60/40 °C				
Size	Type	t _{room} °C	Q kW	H _{max} m	t _s °C	Δp _w kPa	m _w l/h	Q kW	H _{max} m	t _s °C	Δp _w kPa	m _w l/h
TH-6	A	16	32.8	13.4	34.2	7	1410	18.8	16.8	27.3	2	807
		20	30.3	14.0	37.0	6	1301	16.2	17.9	30.0	2	697
	B	16	47.0	11.6	41.3	13	2020	26.9	14.6	31.3	4	1157
		20	43.4	12.0	43.5	11	1864	23.3	15.5	33.5	3	1001
	C	16	76.0	9.4	55.6	18	3267	45.0	11.8	40.3	6	1935
		20	70.3	9.8	56.8	16	3022	39.3	12.5	41.5	5	1690
TH-9	A	16	55.5	13.6	36.6	8	2386	31.7	17.0	28.5	3	1364
		20	51.2	14.1	38.9	7	2201	27.4	18.1	31.1	2	1179
	B	16	71.2	12.2	41.5	12	3060	40.6	15.4	31.4	4	1746
		20	65.7	12.7	43.7	10	2823	35.1	16.5	33.6	3	1509
	C	16	117.9	9.8	56.9	18	5066	69.9	12.3	41.1	6	3003
		20	109.1	10.2	58.0	15	4686	61.0	13.1	42.1	5	2622
Legend:	Type = Type of coil		t _s = Supply air temperature									
	t _{room} = Room air temperature		Δp _w = Water pressure drop									
	Q = Heat output		m _w = Water quantity									
	H _{max} = Maximum mounting height											
Reference:	<ul style="list-style-type: none"> ■ At room air temperature 16 °C: extract air temperature 18 °C ■ At room air temperature 20 °C: extract air temperature 22 °C 											

Table B7: TopVent® TH heat output

3.7 Product information according to ErP

Model	TopVent® TH						Unit
	6 A	6B	6C	9 A	9B	9C	
Cooling capacity (sensible) (P _{rated,c})	–	–	–	–	–	–	kW
Cooling capacity (latent) (P _{rated,c})	–	–	–	–	–	–	kW
Heating capacity (P _{rated,h})	13.2	18.9	29.8	22.6	28.5	46.2	kW
Total electric power input (P _{elec})	0.46	0.53	0.74	0.84	0.96	1.26	kW
Sound power level (L _{WA})	73	75	77	76	77	78	dB
Contact details	Hoval Aktiengesellschaft Austrasse 70, 9490 Vaduz, Liechtenstein www.hoval.com						

Table B8: Product information according to Commission Regulation (EU) 2016/2281, Table 13

3.8 Dimensions and weights

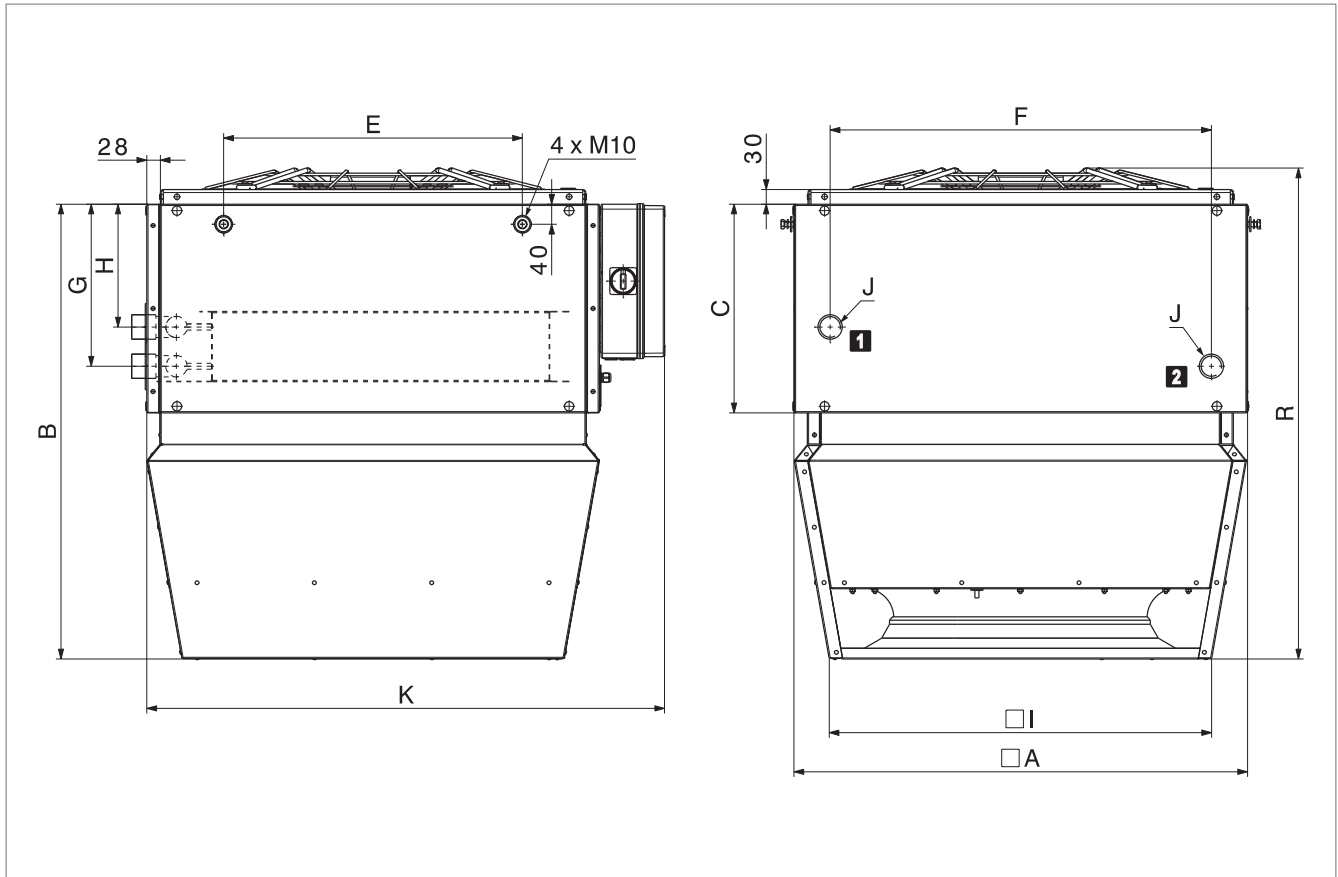

1 Return heating

2 Flow heating

Fig. B4: TopVent® TH dimensional drawing

Unit size		TH-6			TH-9		
Coil type		A	B	C	A	B	C
A	mm	900			1100		
B	mm	905			1050		
C	mm	415			480		
E	mm	594			846		
F	mm	758			882		
G	mm	322			367		
H	mm	244			289		
I	mm	760			935		
K	mm	1030			1230		
R	mm	977			1152		
J	"	Rp 1¼ (internal)			Rp 1½ (internal)		
Water content of heating coil	l	4.6	4.6	7.9	7.4	7.4	12.4
Weight	kg	104	104	111	155	155	166

Table B9: TopVent® TH dimensions and weights

4 Specification texts

4.1 TopVent® TH

Recirculation unit for heating rooms up to 25 m in height with central heat supply; equipped with highly efficient air distributor; maximum floor area reached per unit 537 m² (size 6) and 946 m² respectively (size 9).

The unit consists of the following components:

- Fan unit
- Heating section
- Air-Injector or outlet nozzle
- Unit control box or terminal box
- Optional components

TopVent® TH units comply with all the requirements of the Ecodesign Directive 2009/125/EC relating to environmentally friendly design of energy-related products. They are systems of the 'fan coil unit' type, provided for in Commission Regulation (EU) 2016/2281.

Fan unit

Consisting of maintenance-free, direct-drive axial fan with high-efficiency EC motor and balanced rotating wheel with aerodynamically shaped blades and serrated trailing edge (integrated in the heating section).

Heating section

Housing made of aluzinc sheet, air-tight, flame retardant, hygienic and easy to maintain because of ageing-resistant, silicone-free sealing materials.

The heating section contains:

- The highly efficient heating coil consisting of seamless copper pipes with pressed-on, optimised and profiled aluminium fins and manifolds made of copper; for connection to the hot water supply

Air-Injector

Housing made of aluzinc sheet, air-tight, flame retardant, hygienic and easy to maintain because of ageing-resistant, silicone-free sealing materials, with:

- Vortex air distributor with concentric outlet nozzle, adjustable vanes and integrated absorber hood
- Actuator for infinitely variable adjustment of the air distribution from vertical to horizontal
 - for draught-free air distribution in the hall under changing operating conditions
 - for the rapid and large-area reduction of temperature stratification in the room through induction of secondary air and strong mixing of the room air with supply air
- Supply air temperature sensor

Outlet nozzle (variant)

Housing made of aluzinc sheet, air-tight, flame retardant, hygienic and easy to maintain because of ageing-resistant, silicone-free sealing materials. Concentric outlet nozzle with a supply air sensor.

Unit control box

Control box fitted at the side of the unit for connection of the power supply and housing the control components that facilitate energy-optimised operation, controlled by the control system TopTronic® C. Plastic casing, protection rating IP 56. The following components are installed:

- Isolation switch
- Circuit board with all required electrical components, unit controller (clipped on) as well as connection terminals for the following external connections:
 - Heating valve
 - Heating pump
 - Return temperature sensor
 - Door contact

The circuit board is fitted with push-in terminals facilitating easy installation of the connection cables. All components in the unit control box as well as sensors and actuators in the unit are fully factory-wired.

Power supply and bus connection to be installed on site.

Terminal box (variant)

Terminal box fitted at the side of the housing for connection of the power supply and peripheral components of the unit. Plastic casing, protection rating IP 56. The following components are installed:

- Isolation switch
- Circuit board with all required electrical components as well as connection terminals for the following signals:
 - Input Enable fan
 - Input Control signal fan
 - Output Control signal next fan
 - Input Control signal actuator Air-Injector
 - Output Control signal next actuator Air-Injector
 - Output Feedback control signal Air-Injector
 - Output Error
- The following sensors and actuators in the unit are factory-wired:
 - Fan
 - Supply air temperature sensor
 - Actuator Air-Injector

Options for the unit

Suspension set:

for ceiling installation of the unit consisting of 4 pairs U-profiles made of aluzinc sheet steel, height-adjustable to 1300 mm.

Filter box:

Housing made of aluzinc sheet with 2 ISO coarse 60% bag filters (G4), with differential pressure switch for filter monitoring, factory-wired to the circuit board in the unit control box.

Flat filter box:

Housing made of aluzinc sheet with 4 pleated ISO coarse 60% cell filters (G4), with differential pressure switch for filter monitoring, factory-wired to the circuit board in the unit control box.

Standard paint finish:

Exterior painting in Hoval red (RAL 3000), including optional components and suspension set

Paint finish as desired:

Exterior painting of the unit in choice of RAL colour, including optional components and suspension set.

Recirculation silencer:

as an attachment to the unit, made of aluzinc sheet metal, lined with sound insulation matting, insertion attenuation 3 dB

Acoustic cowl:

consisting of an absorber hood of large volume, insertion attenuation 4 dB

Hydraulic assembly diverting system:

Prefabricated assembly for hydraulic diverting system, consisting of mixing valve, regulating valve, ball valve, automatic air vent and screw connections for connection to the unit and to the distributor circuit; mixing valve with plug-in connection, sized for the coil in the unit and the Hoval TopTronic® C control system.

Mixing valve:

Mixing valve with modulating rotary actuator and plug-in connection, sized for the coil in the unit.

Pump control for mixing or injection system:

Electrical components for controlling a mixing or injection circuit in the load circuit, factory-installed in the unit control box.

Return temperature sensor:

Temperature sensor for monitoring the heating medium.

4.2 TopTronic® C – System control

Zone-based control system for the energy-optimised operation of decentralised Hoval indoor climate systems. Maximum system size per system bus: 64 control zones with up to 10 supply and extract air handling units or supply air handling units and 10 recirculation air handling units each.

Zone allocation

Configured in advance for the customer at the factory:

	Room designation	Unit type
Zone 1:	_____	_____
Zone 2:	_____	_____
...		

System structure:

- Zone control panel made of coated sheet steel (light grey RAL 7035), ... x ... x ... mm, with:
 - System operator terminal
 - Fresh air temperature sensor
 - 1 zone controller and 1 room temperature sensor per zone (expandable to up to 4 room temperature sensors per zone)
 - Safety relay
 - Electrical cabinet internally pre-wired, all components routed to terminals
- Zone bus: as serial bus for communication with all controllers in one control zone, with robust bus protocol via shielded, twisted bus cable (provided by the client)
- Unit controller: installed in the particular indoor climate unit, works autonomously according to the specifications of the zone controller
- Heating/cooling demand per zone with feedback monitoring

Functions, standard

- Zone-based autonomous room control. Temperature and ventilation control separately adjustable for each zone
- Room temperature control via room-supply air cascade by means of energy-optimised double sequence control with priority circuit for energy recovery (supply and extract air handling units)
- Intelligent automatic heating to reach the desired room temperature at the switching time
- 5 adjustable room temperature set values per zone:
 - Cooling protection (lower setpoint in standby)
 - Overheating protection (upper setpoint in standby)
 - Room set value winter
 - Room set value summer
 - Night cooling set value (free cooling) (supply and extract air handling units)
- Destratification mode for even temperature distribution

- Main operating modes of supply and extract air handling units:
 - VE Ventilation, infinitely variably adjustment
 - AQ.... Air quality, automatic control with Hoval combination sensor (option), optional reference variable:
 - CO₂ or VOC
 - Air humidity (optimised dehumidification mode)
 - REC . Recirculation, infinitely variably adjustment
 - DES.. Destratification
 - EA Exhaust air, infinitely variably adjustment
 - SA Supply air, infinitely variably adjustment
 - ST Standby
- Main operating modes of supply air units:
 - REC . Recirculation, infinitely variably adjustment
 - DES.. Destratification
 - SA Supply air, infinitely variably adjustment
 - ST Standby
- Main operating modes of recirculated air units:
 - REC . Recirculation, infinitely variably adjustment
 - DES.. Destratification
 - ST Standby
- Forced heating (construction site heating) can be activated on each device before completion of the overall system (activation by Hoval service technician)
- Control of draught-free air distribution with the Hoval Air-Injector: the discharge direction is adjusted infinitely variably and automatically according to the respective operating condition and the existing temperatures (heating/cooling).

Operation

- TopTronic® C-ST system operator terminal: touch panel for visualisation and control of all Hoval indoor climate units registered on the bus

Options for operation

- Hoval C-SSR operating software, for visualisation on customer's PC
- TopTronic® C-ZT as zone operator terminal: for simple on-site operation of a control zone
- Manual operating selector switches
- Manual operating selector buttons
- Operating of the units via building management system via standardised interfaces:
 - BACnet
 - Modbus IP
 - Modbus RTU

Alarms, protection

- Central alarm management with registration of all alarms (timestamp, priority, status) in an alarm list and alarm memory of the last 50 alarms; forwarding via e-mail can be set in the parameters.
- If there is a failure of communication, bus stations, sensor systems or supply media, each part of the system transitions to a protection mode which safeguards operation.
- A maintenance mode implemented in the control algorithm for testing all physical data points and alarms guarantees high reliability.
- Pre-programmed data points retrievable via logger function for 1 year

Options for the zone control panel

- Alarm lamp
- Socket

Per zone

- The change-over between heating and cooling can be either automatic or manual
 - Cooling lock switch for automatic changeover
 - Heating/cooling switch for manual changeover
- Additional room air temperature sensors (max. 3)
- Combination sensor room air quality, temperature and humidity
- Combination sensor fresh air temperature and humidity
- Transfer of actual values and setpoints from external systems (0...10 V; 4 - 20 mA)
- Load shedding input
- Operating selector switches on terminal
- Operating selector buttons on terminal
- Control of distributor pump, incl. power supply

Power distribution:

- Circuit breakers and output terminals for Hoval indoor climate units
- Safety relay (4-pin)

4.3 TopTronic® C – System control for TopVent® C-SYS

Control system for the energy-optimised operation of decentralised Hoval indoor climate systems. Maximum system size per system bus: 1 control zone with up to 6 supply air handling units and 10 recirculation air handling units.

System structure

- Zone control panel, designed as compact cabinet for wall installation, made of coated sheet steel (light grey RAL 7035), 380 × 300 × 210 mm, with:
 - Operating panel
 - Zone controller
 - Fresh air temperature sensor
 - 1 Room temperature sensor (expandable to up to 4 room temperature sensors)
 - Safety relay
 - Electrical cabinet internally pre-wired
- Zone bus: as serial bus for communication with all controllers in the control zone, with robust bus protocol via shielded, twisted bus cable (provided by the client)
- Unit controller: installed in the particular indoor climate unit, works autonomously according to the specifications of the zone controller
- Circuit board with external connections for:
 - Collective alarm
 - Forced off
 - Heating demand
 - Setpoint heating demand
 - Fault heat supply
 - Cooling demand
 - Fault cold supply
 - External enabling heating/cooling (for automatic changeover)
 - External setting heating/cooling (for manual changeover)
 - Changeover valves heating/cooling
 - Additional room air temperature sensors (max. 3)
 - External setpoint fresh air ratio
 - Operating selector switch on terminal (digital)
 - Operating selector button on terminal

Functions, standard

- Room temperature control via sequential control of the coils
- Intelligent automatic heating to reach the desired room temperature at the switching time
- 4 adjustable room temperature set values per zone:
 - Cooling protection (lower setpoint in standby)
 - Overheating protection (upper setpoint in standby)
 - Room set value winter
 - Room set value summer
- Destratification mode for even temperature distribution

- Main operating modes of supply air units:
REC . Recirculation, infinitely variably adjustment
DES.. Destratification
SA Supply air, infinitely variably adjustment
ST Standby
- Main operating modes of recirculated air units:
REC . Recirculation, infinitely variably adjustment
DES.. Destratification
ST Standby
- Forced heating (construction site heating) can be activated on each device before completion of the overall system (activation by Hoval service technician)
- Control of draught-free air distribution with the Hoval Air-Injector: the discharge direction is adjusted infinitely variably and automatically according to the respective operating condition and the existing temperatures (heating/cooling).

Operation

- Operating panel with LCD display, installed in the door of the zone control panel for visualisation and control of all Hoval indoor climate units registered on the bus

Options for operation

- Hoval C-SSR operating software, for visualisation on customer's PC
- Operating of the units via building management system via standardised interfaces:
 - BACnet
 - Modbus IP
 - Modbus RTU

Alarms, protection

- Central alarm management with registration of all alarms (timestamp, priority, status) in an alarm list and alarm memory of the last 50 alarms; forwarding via e-mail can be set in the parameters.
- If there is a failure of communication, bus stations, sensor systems or supply media, each part of the system transitions to a protection mode which safeguards operation.
- A maintenance mode implemented in the control algorithm for testing all physical data points and alarms guarantees high reliability.
- Pre-programmed data points retrievable via logger function for 1 year

Options for the zone control panel

- Additional room air temperature sensors (max. 3)

4.4 EasyTronic EC

Room temperature controller with timer for TopVent® TH, TC, TV recirculation units and TopVent® TW air curtains, protection rating IP 30, with the following functions:

- Recording the room temperature with the integrated temperature sensor
- Connection option for external room temperature sensor
- Room temperature control in on/off mode
- Lowering of the room temperature setpoint value via week programme
- Unit control depending on a door contact switch
- Manual adjustment of the fan speed
- Manual adjustment of air distribution with the Hoval Air-Injector from vertical to horizontal (for TopVent® TH, TC)
- Signal for switching a pump or a valve
- Fan off delay in cooling mode
- External heating/cooling changeover
- Alarm display
- Connection to the building management system via Modbus RTU

Options:

- External room temperature sensor (protection rating IP 65)



TopVent® TC

Recirculation units for heating and cooling spaces up to 25 m in height with central heat and cold supply (2-pipe-system)

1 Use	20
2 Construction and operation	20
3 Technical data	23
4 Specification texts	27

C

1 Use

1.1 Intended use

TopVent® TC units are recirculation units for heating and cooling spaces up to 25 m in height with central heat and cold supply. They have the following functions:

- Heating (with connection to a hot water supply)
- Cooling (with connection to a water chiller)
- Recirculation operation
- Air distribution and destratification with adjustable Air-Injector
- Air filtration (option)

TopVent® TC units comply with all the requirements of the Ecodesign Directive 2009/125/EC relating to environmentally friendly design of energy-related products. It is a system of the 'fan coil unit' type.

The Hoval TopTronic® C integrated control system ensures energy-efficient, demand-based operation of Hoval indoor climate systems.

Intended use also includes compliance with the operating instructions. Any usage over and above this use is considered to be not as intended. The manufacturer can accept no liability for damage resulting from improper use.

1.2 User group

The units are only allowed to be installed, operated and maintained by authorised and instructed personnel who are well acquainted with the units and are informed about possible dangers.

The operating instructions are for operating engineers as well as specialists in building, heating and ventilation technology.

2 Construction and operation

2.1 Construction

The TopVent® TC unit consists of the following components:

- Fan unit:
Diagonal fan with energy-saving EC motor, maintenance-free and infinitely variable
- Heating/cooling section:
Contains the heating/cooling coil for heating and cooling the supply air with hot water or cold water and the condensate separator for the condensate generated
- Air-Injector:
The Air-Injector is a patented, infinitely variable vortex air distributor for the draught-free introduction of air into the hall under changing operating conditions.

As part of the TopTronic® C control system, the unit control box is an integral component.

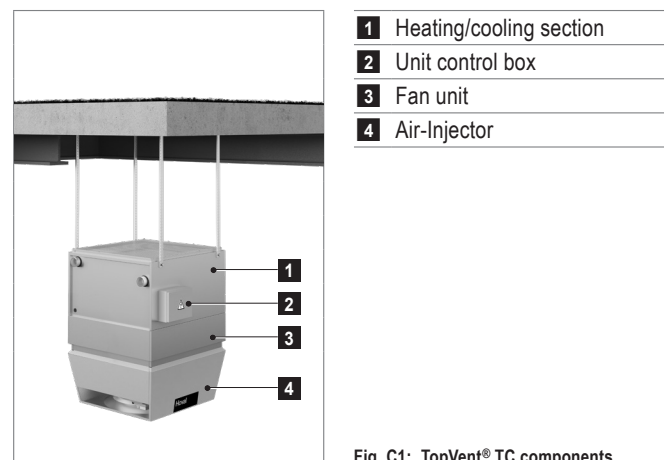
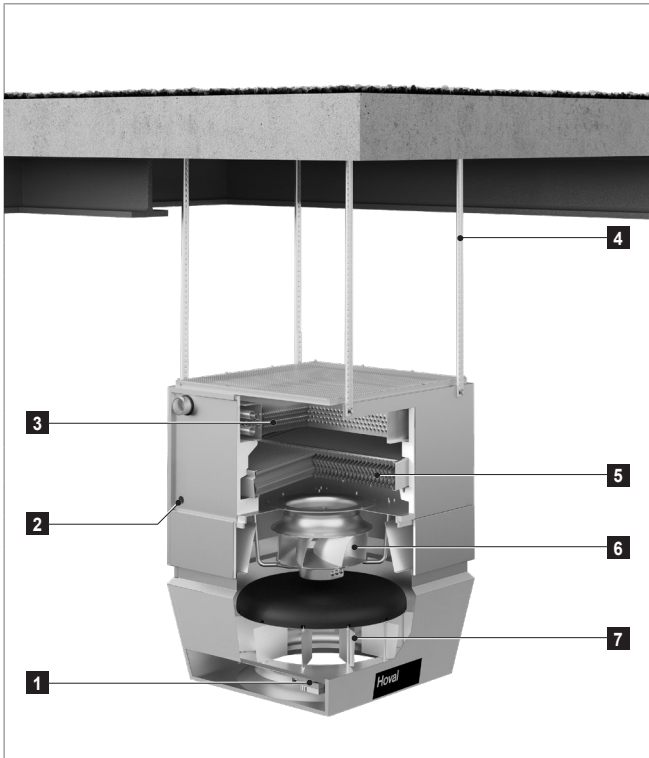

Fig. C1: TopVent® TC components



- 1 Actuator Air-Injector
- 2 Condensate connection
- 3 Heating/cooling coil
- 4 Suspension set
- 5 Condensate separator
- 6 Fan
- 7 Air-Injector

Fig. C2: TopVent® TC construction

2.2 Function diagram

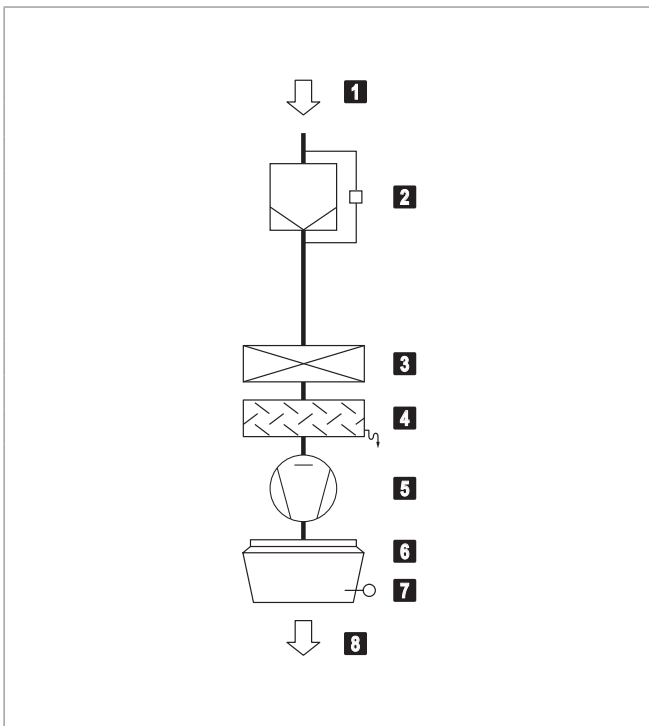

- 1 Extract air
- 2 Air filter with differential pressure switch (option)
- 3 Heating/cooling coil
- 4 Condensate separator
- 5 Fan
- 6 Air-Injector with actuator
- 7 Supply air temperature sensor
- 8 Supply air

Fig. C3: TopVent® TC function diagram

2.3 Operating modes

The TopVent® TC has the following operating modes:

- Recirculation
- Recirculation speed 1
- Standby

The TopTronic® C control system regulates these operating modes automatically for each control zone in accordance with the specifications in the calendar.

The following points also apply:

- The operating mode of a control zone can be switched over manually.
- Each TopVent® TC unit can operate individually in a local operating mode: Off, Recirculation, Recirculation speed 1.

Code	Operating mode	Description
REC	Recirculation On/Off operation: during heat or cool demand, the unit draws in room air, heats or cools it and blows it back into the room. The room temperature set value day is active.	Fan speed 1/2 ¹⁾ Heating/cooling on ¹⁾ Depending on heat or cool demand
DES	■ Destratification: To avoid heat build-up under the ceiling, it may be appropriate to switch on the fan when there is no heat or cool demand (either in permanent operation or in on/off operation depending on the temperature stratification, as desired).	Fan speed 2 Heating/cooling off
REC1	Recirculation speed 1 The same as REC, but the unit operates only at speed 1 (low air flow rate)	Fan speed 1 ¹⁾ Heating/cooling on ¹⁾ Depending on heat or cool demand
DES	■ Destratification: The same as for REC, but the unit operates only at speed 1	Fan speed 1 Heating/cooling off
ST	Standby The unit is ready for operation. The following operating modes are activated if required:	
CPR	■ Cooling protection: If the room temperature drops below the set value for cooling protection, the unit heats up the room in recirculation operation.	Fan speed 2 Heating on
OPR	■ Overheating protection: If the room temperature rises above the set value for overheating protection, the unit cools down the room in recirculation operation.	Fan speed 2 Cooling..... on
L_OFF	Off (local operating mode) The unit is switched off.	Fan off Heating/cooling off
-	Forced heating The unit draws in room air, warms it and blows it back into the room. Forced heating is activated by connecting the unit to a power supply (only if there is no bus connection to the zone controller). For example, it is suitable for heating the hall before taking the control system into operation or if the controller fails during the heating period.	Fan speed 2 Heating on

Table C1: TopVent® TC operating modes

3 Technical data

3.1 Type code

TC - 6 - C ...	
Unit type	TopVent® TC
Unit size	6 or 9
Heating/cooling section	C with coil type C D with coil type D
Further options	

Table C2: TopVent® TC type code

3.2 Application limits

Extract air temperature	max.	°C	50
Supply air temperature	max.	°C	60
Temperature of the heating medium ¹⁾	max.	°C	90
Pressure of the heating medium	max.	kPa	800
Air flow rate	Size 6:	min.	m³/h 3100
	Size 9:	min.	m³/h 5000
Condensate quantity	Size 6:	max.	kg/h 90
	Size 9:	max.	kg/h 150
The units cannot be used in:			
<ul style="list-style-type: none"> ■ Damp locations ■ Places with a corrosive or aggressive environment ■ Spaces with a large amount of dust ■ Areas where there is danger of explosion 			
¹⁾ Design for higher temperatures on request			

Table C3: TopVent® TC application limits

3.3 Electrical connection

Unit type		TC-6	TC-9
Supply voltage	V AC	3 × 400	3 × 400
Permitted voltage tolerance	%	± 5	± 5
Frequency	Hz	50	50
Connected load	kW	3.6	3.6
Current consumption max.	A	5.9	5.9
Series fuse	A	13	13
Protection rating	-	IP 54	IP 54

Table C4: TopVent® TC electrical connection

3.4 Air flow rate

Unit type		TC-6	TC-9
Nominal air flow rate	m³/h	6000	9000
Floor area covered	m²	537	946

Table C5: TopVent® TC air flow rate

3.5 Sound level

Unit type		TC-6-C	TC-9-C
Sound pressure level (at a distance of 5 m) ¹⁾	dB(A)	51	59
Total sound power level	dB(A)	73	81
Octave sound power level	63 Hz	dB 41	49
	125 Hz	dB 59	67
	250 Hz	dB 62	70
	500 Hz	dB 65	73
	1000 Hz	dB 67	75
	2000 Hz	dB 67	75
	4000 Hz	dB 66	74
8000 Hz	dB 61	68	

¹⁾ with a hemispherical radiation pattern in a low-reflection room

Table C6: TopVent® TC sound level

3.6 Heat output

Heating medium temperature			80/60 °C					60/40 °C				
Size	Type	t _{room} °C	Q kW	H _{max} m	t _s °C	Δp _w kPa	m _w l/h	Q kW	H _{max} m	t _s °C	Δp _w kPa	m _w l/h
TC-6	C	16	76.0	9.4	55.6	18	3267	45.0	11.8	40.3	6	1935
		20	70.3	9.8	56.8	16	3022	39.3	12.5	41.5	5	1690
TC-9	C	16	117.9	9.8	56.9	18	5066	69.9	12.3	41.1	6	3003
		20	109.1	10.2	58.0	15	4686	61.0	13.1	42.1	5	2622
	D	16	140.7	9.1	64.4	15	6045	85.4	11.3	46.2	5	3670
		20	130.4	9.5	65.0	13	5600	75.1	12.0	46.8	4	3225
Legend:		Type = Type of coil t _{room} = Room air temperature Q = Heat output H _{max} = Maximum mounting height					t _s = Supply air temperature Δp _w = Water pressure drop m _w = Water quantity					
Reference:		<ul style="list-style-type: none"> ■ At room air temperature 16 °C: extract air temperature 18 °C ■ At room air temperature 20 °C: extract air temperature 22 °C 										

Table C7: TopVent® TC heat output

3.7 Cooling capacity

Cooling medium temperature				6/12 °C						8/14 °C					
Size	Type	t _{room} °C	RH _{room} %	Q _{sen} kW	Q _{tot} kW	t _s °C	Δp _w kPa	m _w l/h	m _c kg/h	Q _{sen} kW	Q _{tot} kW	t _s °C	Δp _w kPa	m _w l/h	m _c kg/h
TC-6	C	22	50	20.4	20.4	13.9	15	2925	0.0	18.0	18.0	15.1	12	2573	0.0
			70	18.5	27.7	14.9	28	3960	13.5	16.0	21.4	16.1	17	3064	7.9
		26	50	25.2	31.1	15.5	36	4448	8.6	22.7	24.8	16.7	23	3552	3.0
			70	23.2	43.7	16.5	71	6263	30.2	20.8	37.5	17.7	52	5367	24.6
TC-9	C	22	50	31.4	31.4	13.6	15	4496	0.0	27.6	27.6	14.9	12	3947	0.0
			70	28.4	44.7	14.6	31	6401	23.9	24.6	28.2	15.9	12	4031	5.2
		26	50	38.8	49.9	15.2	38	7149	16.3	35.0	35.0	16.4	19	5013	0.0
			70	35.9	69.8	16.2	75	9989	49.8	32.0	53.2	17.4	44	7619	31.1
	D	22	50	37.1	37.1	11.8	13	5307	0.0	32.2	32.2	13.4	10	4613	0.0
			70	34.6	56.7	12.6	30	8118	32.5	29.7	45.1	14.2	19	6459	22.6
		26	50	46.4	62.4	12.7	36	8941	23.5	41.6	50.9	14.3	24	7282	13.6
			70	43.9	87.4	13.5	70	12513	63.9	39.1	75.8	15.1	53	10854	54.0
Legend:		Type = Type of coil t _{room} = Room air temperature RH _{room} = Relative humidity of the room air Q _{sen} = Sensible cooling capacity Q _{tot} = Total cooling capacity					t _s = Supply air temperature Δp _w = Water pressure drop m _w = Water quantity m _c = Condensate quantity								
Reference:		<ul style="list-style-type: none"> ■ At room air temperature 22 °C: extract air temperature 24 °C ■ At room air temperature 26 °C: extract air temperature 28 °C 													

Table C8: TopVent® TC cooling capacity

3.8 Product information according to ErP

Model	TopVent® TC			Unit
	6-C	9-C	9-D	
Cooling capacity (sensible) ($P_{rated,c}$)	26.5	41.0	48.6	kW
Cooling capacity (latent) ($P_{rated,c}$)	5.6	7.3	15.2	kW
Heating capacity ($P_{rated,h}$)	29.8	46.2	54.2	kW
Total electric power input (P_{elec})	0.67	1.23	1.34	kW
Sound power level (L_{WA})	73	81	81	dB
Contact details	Hoval Aktiengesellschaft Austrasse 70, 9490 Vaduz, Liechtenstein www.hoval.com			

Table C9: Product information according to Commission Regulation (EU) 2016/2281, Table 13

3.9 Dimensions and weights

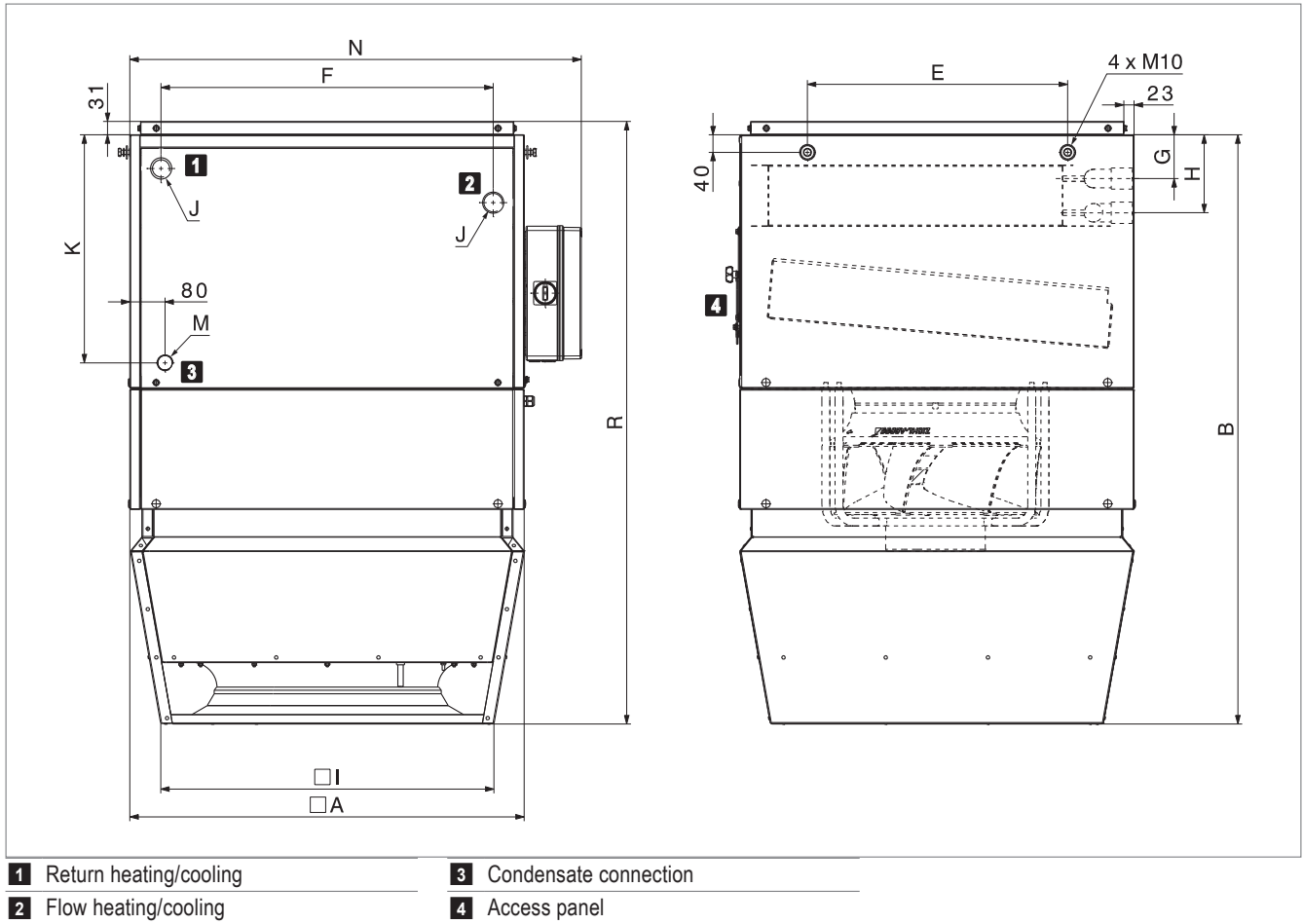

Fig. C4: TopVent® TC dimensional drawing

Unit size			TC-6	TC-9	TC-9
Coil type			C	C	D
A	mm		900	1100	1100
B	mm		1344	1430	1430
E	mm		594	846	846
F	mm		758	882	882
G	mm		77	93	85
H	mm		155	171	180
I	mm		760	935	935
K	mm		521	558	558
N	mm		1030	1230	1230
R	mm		1375	1463	1463
J	"		Rp 1¼ (internal)	Rp 1½ (internal)	Rp 2 (internal)
M	"		G 1 (external)	G 1 (external)	G 1 (external)
Water content of heating/cooling coil		l	7.9	12.4	19.2
Weight		kg	216	265	276

Table C10: TopVent® TC dimensions and weights

4 Specification texts

4.1 TopVent® TC

Recirculation unit for heating and cooling rooms up to 25 m in height with central heat and cold supply (2-pipe system); equipped with highly efficient air distributor; maximum floor area reached per unit 537 m² (size 6) and 946 m² respectively (size 9).

The unit consists of the following components:

- Fan unit
- Heating/cooling section
- Air-Injector
- Unit control box or terminal box
- Optional components

TopVent® TC units comply with all the requirements of the Ecodesign Directive 2009/125/EC relating to environmentally friendly design of energy-related products. They are systems of the 'fan coil unit' type, provided for in Commission Regulation (EU) 2016/2281.

Fan unit

Consisting of radial fan with high-efficiency EC motor, backwards-curved, three-dimensional contoured blades and free-running rotor made of a high-performance composite material, aerodynamically optimised inflow nozzle, low-noise, with integrated overload protection (integrated in the heating/cooling section).

Heating/cooling section

Housing made of aluzinc sheet, air-tight, flame retardant, hygienic and easy to maintain because of ageing-resistant, silicone-free sealing materials, internally insulated with close-pored polyurethane.

The heating/cooling section contains:

- The highly efficient heating/cooling coil consisting of seamless copper pipes with pressed-on, optimised and profiled aluminium fins and manifolds made of copper; for connection to the hot water and cold water supply
- The pull-out condensate separator with collecting channel, made of high-quality corrosion-resistant material, with a downslope in all directions for rapid draining
- The condensate trap for connecting to a condensate drain (supplied).

Air-Injector

Housing made of aluzinc sheet, air-tight, flame retardant, hygienic and easy to maintain because of ageing-resistant, silicone-free sealing materials, internally insulated with close-pored polyurethane, with:

- Vortex air distributor with concentric outlet nozzle, adjustable vanes and integrated absorber hood
- Actuator for infinitely variable adjustment of the air distribution from vertical to horizontal
 - for draught-free air distribution in the hall under changing operating conditions
 - for the rapid and large-area reduction of temperature stratification in the room through induction of secondary air and strong mixing of the room air with supply air
- Supply air temperature sensor

Unit control box

Control box fitted at the side of the unit for connection of the power supply and housing the control components that facilitate energy-optimised operation, controlled by the control system TopTronic® C. Plastic casing, protection rating IP 56. The following components are installed:

- Isolation switch
- Circuit board with all required electrical components, unit controller (clipped on) as well as connection terminals for the following external connections:
 - Heating/cooling valve
 - Heating/cooling pump
 - Return temperature sensor
 - Condensate pump
 - Door contact

The circuit board is fitted with push-in terminals facilitating easy installation of the connection cables. All components in the unit control box as well as sensors and actuators in the unit are fully factory-wired.

Power supply and bus connection to be installed on site.

Terminal box (variant)

Terminal box fitted at the side of the housing for connection of the power supply and peripheral components of the unit. Plastic casing, protection rating IP 56. The following components are installed:

- Isolation switch
- Circuit board with all required electrical components as well as connection terminals for the following signals:
 - Input Enable fan
 - Input Control signal fan
 - Output Control signal next fan
 - Input Control signal actuator Air-Injector
 - Output Control signal next actuator Air-Injector
 - Output Feedback control signal Air-Injector
 - Output Error
- The following sensors and actuators in the unit are factory-wired:
 - Fan
 - Supply air temperature sensor
 - Actuator Air-Injector

to the unit and to the distributor circuit; mixing valve with plug-in connection, sized for the coil in the unit and the Hoval TopTronic® C control system.

Mixing valve:

Mixing valve with modulating rotary actuator and plug-in connection, sized for the coil in the unit.

Condensate pump:

Consisting of a centrifugal pump and a drip tray, max. delivery rate of 150 l/h with a delivery head of 3 m. Condensate pump with connection cable enclosed.

Pump control for mixing or injection system:

Electrical components for controlling a mixing or injection circuit in the load circuit, factory-installed in the unit control box.

Return temperature sensor:

Temperature sensor for monitoring the heating medium.

Options for the unit

Suspension set:

for ceiling installation of the unit consisting of 4 pairs U-profiles made of aluzinc sheet steel, height-adjustable to 1300 mm.

Filter box:

Housing made of aluzinc sheet with 2 ISO coarse 60% bag filters (G4), with differential pressure switch for filter monitoring, factory-wired to the circuit board in the unit control box.

Flat filter box:

Housing made of aluzinc sheet with 4 pleated ISO coarse 60% cell filters (G4), with differential pressure switch for filter monitoring, factory-wired to the circuit board in the unit control box.

Standard paint finish:

Exterior painting in Hoval red (RAL 3000), including optional components and suspension set

Paint finish as desired:

Exterior painting of the unit in choice of RAL colour, including optional components and suspension set

Recirculation silencer:

as an attachment to the unit, made of aluzinc sheet metal, lined with sound insulation matting, insertion attenuation 3 dB

Hydraulic assembly diverting system:

Prefabricated assembly for hydraulic diverting system, consisting of mixing valve, regulating valve, ball valve, automatic air vent and screw connections for connection

4.2 TopTronic® C – System control

Zone-based control system for the energy-optimised operation of decentralised Hoval indoor climate systems. Maximum system size per system bus: 64 control zones with up to 10 supply and extract air handling units or supply air handling units and 10 recirculation air handling units each.

Zone allocation

Configured in advance for the customer at the factory:

	Room designation	Unit type
Zone 1:	_____	_____
Zone 2:	_____	_____
...		

System structure:

- Zone control panel made of coated sheet steel (light grey RAL 7035), ... x ... x ... mm, with:
 - System operator terminal
 - Fresh air temperature sensor
 - 1 zone controller and 1 room temperature sensor per zone (expandable to up to 4 room temperature sensors per zone)
 - Safety relay
 - Electrical cabinet internally pre-wired, all components routed to terminals
- Zone bus: as serial bus for communication with all controllers in one control zone, with robust bus protocol via shielded, twisted bus cable (provided by the client)
- Unit controller: installed in the particular indoor climate unit, works autonomously according to the specifications of the zone controller
- Heating/cooling demand per zone with feedback monitoring

Functions, standard

- Zone-based autonomous room control. Temperature and ventilation control separately adjustable for each zone
- Room temperature control via room-supply air cascade by means of energy-optimised double sequence control with priority circuit for energy recovery (supply and extract air handling units)
- Intelligent automatic heating to reach the desired room temperature at the switching time
- 5 adjustable room temperature set values per zone:
 - Cooling protection (lower setpoint in standby)
 - Overheating protection (upper setpoint in standby)
 - Room set value winter
 - Room set value summer
 - Night cooling set value (free cooling) (supply and extract air handling units)
- Destratification mode for even temperature distribution

- Main operating modes of supply and extract air handling units:
 - VE Ventilation, infinitely variably adjustment
 - AQ.... Air quality, automatic control with Hoval combination sensor (option), optional reference variable:
 - CO₂ or VOC
 - Air humidity (optimised dehumidification mode)
 - REC . Recirculation, infinitely variably adjustment
 - DES.. Destratification
 - EA Exhaust air, infinitely variably adjustment
 - SA Supply air, infinitely variably adjustment
 - ST Standby
- Main operating modes of supply air units:
 - REC . Recirculation, infinitely variably adjustment
 - DES.. Destratification
 - SA Supply air, infinitely variably adjustment
 - ST Standby
- Main operating modes of recirculated air units:
 - REC . Recirculation, infinitely variably adjustment
 - DES.. Destratification
 - ST Standby
- Forced heating (construction site heating) can be activated on each device before completion of the overall system (activation by Hoval service technician)
- Control of draught-free air distribution with the Hoval Air-Injector: the discharge direction is adjusted infinitely variably and automatically according to the respective operating condition and the existing temperatures (heating/cooling).

Operation

- TopTronic® C-ST system operator terminal: touch panel for visualisation and control of all Hoval indoor climate units registered on the bus

Options for operation

- Hoval C-SSR operating software, for visualisation on customer's PC
- TopTronic® C-ZT as zone operator terminal: for simple on-site operation of a control zone
- Manual operating selector switches
- Manual operating selector buttons
- Operating of the units via building management system via standardised interfaces:
 - BACnet
 - Modbus IP
 - Modbus RTU

Alarms, protection

- Central alarm management with registration of all alarms (timestamp, priority, status) in an alarm list and alarm memory of the last 50 alarms; forwarding via e-mail can be set in the parameters.
- If there is a failure of communication, bus stations, sensor systems or supply media, each part of the system transitions to a protection mode which safeguards operation.
- A maintenance mode implemented in the control algorithm for testing all physical data points and alarms guarantees high reliability.
- Pre-programmed data points retrievable via logger function for 1 year

Options for the zone control panel

- Alarm lamp
- Socket

Per zone

- The change-over between heating and cooling can be either automatic or manual
 - Cooling lock switch for automatic changeover
 - Heating/cooling switch for manual changeover
- Additional room air temperature sensors (max. 3)
- Combination sensor room air quality, temperature and humidity
- Combination sensor fresh air temperature and humidity
- Transfer of actual values and setpoints from external systems (0...10 V; 4 - 20 mA)
- Load shedding input
- Operating selector switches on terminal
- Operating selector buttons on terminal
- Control of distributor pump, incl. power supply

Power distribution:

- Circuit breakers and output terminals for Hoval indoor climate units
- Safety relay (4-pin)

4.3 TopTronic® C – System control for TopVent® C-SYS

Control system for the energy-optimised operation of decentralised Hoval indoor climate systems. Maximum system size per system bus: 1 control zone with up to 6 supply air handling units and 10 recirculation air handling units.

System structure

- Zone control panel, designed as compact cabinet for wall installation, made of coated sheet steel (light grey RAL 7035), 380 × 300 × 210 mm, with:
 - Operating panel
 - Zone controller
 - Fresh air temperature sensor
 - 1 Room temperature sensor (expandable to up to 4 room temperature sensors)
 - Safety relay
 - Electrical cabinet internally pre-wired
- Zone bus: as serial bus for communication with all controllers in the control zone, with robust bus protocol via shielded, twisted bus cable (provided by the client)
- Unit controller: installed in the particular indoor climate unit, works autonomously according to the specifications of the zone controller
- Circuit board with external connections for:
 - Collective alarm
 - Forced off
 - Heating demand
 - Setpoint heating demand
 - Fault heat supply
 - Cooling demand
 - Fault cold supply
 - External enabling heating/cooling (for automatic changeover)
 - External setting heating/cooling (for manual changeover)
 - Changeover valves heating/cooling
 - Additional room air temperature sensors (max. 3)
 - External setpoint fresh air ratio
 - Operating selector switch on terminal (digital)
 - Operating selector button on terminal

Functions, standard

- Room temperature control via sequential control of the coils
- Intelligent automatic heating to reach the desired room temperature at the switching time
- 4 adjustable room temperature set values per zone:
 - Cooling protection (lower setpoint in standby)
 - Overheating protection (upper setpoint in standby)
 - Room set value winter
 - Room set value summer
- Destratification mode for even temperature distribution

- Main operating modes of supply air units:
 - REC . Recirculation, infinitely variably adjustment
 - DES.. Destratification
 - SA Supply air, infinitely variably adjustment
 - ST Standby
- Main operating modes of recirculated air units:
 - REC . Recirculation, infinitely variably adjustment
 - DES.. Destratification
 - ST Standby
- Forced heating (construction site heating) can be activated on each device before completion of the overall system (activation by Hoval service technician)
- Control of draught-free air distribution with the Hoval Air-Injector: the discharge direction is adjusted infinitely variably and automatically according to the respective operating condition and the existing temperatures (heating/cooling).

Operation

- Operating panel with LCD display, installed in the door of the zone control panel for visualisation and control of all Hoval indoor climate units registered on the bus

Options for operation

- Hoval C-SSR operating software, for visualisation on customer's PC
- Operating of the units via building management system via standardised interfaces:
 - BACnet
 - Modbus IP
 - Modbus RTU

Alarms, protection

- Central alarm management with registration of all alarms (timestamp, priority, status) in an alarm list and alarm memory of the last 50 alarms; forwarding via e-mail can be set in the parameters.
- If there is a failure of communication, bus stations, sensor systems or supply media, each part of the system transitions to a protection mode which safeguards operation.
- A maintenance mode implemented in the control algorithm for testing all physical data points and alarms guarantees high reliability.
- Pre-programmed data points retrievable via logger function for 1 year

Options for the zone control panel

- Additional room air temperature sensors (max. 3)

4.4 EasyTronic EC

Room temperature controller with timer for TopVent® TH, TC, TV recirculation units and TopVent® TW air curtains, protection rating IP 30, with the following functions:

- Recording the room temperature with the integrated temperature sensor
- Connection option for external room temperature sensor
- Room temperature control in on/off mode
- Lowering of the room temperature setpoint value via week programme
- Unit control depending on a door contact switch
- Manual adjustment of the fan speed
- Manual adjustment of air distribution with the Hoval Air-Injector from vertical to horizontal (for TopVent® TH, TC)
- Signal for switching a pump or a valve
- Fan off delay in cooling mode
- External heating/cooling changeover
- Alarm display
- Connection to the building management system via Modbus RTU

Options:

- External room temperature sensor (protection rating IP 65)



TopVent® THC

Recirculation units for heating and cooling spaces up to 25 m in height with central heat and cold supply (4-pipe-system)

1 Use	34
2 Construction and operation	34
3 Technical data.....	37
4 Specification texts	41

D

1 Use

1.1 Intended use

TopVent® THC units are recirculation units for heating and cooling spaces up to 25 m in height with central heat and cold supply. They have the following functions:

- Heating (with connection to a hot water supply)
- Cooling (with connection to a water chiller)
- Recirculation operation
- Air distribution and destratification with adjustable Air-Injector
- Air filtration (option)

TopVent® THC units comply with all the requirements of the Ecodesign Directive 2009/125/EC relating to environmentally friendly design of energy-related products. It is a system of the 'fan coil unit' type.

The Hoval TopTronic® C integrated control system ensures energy-efficient, demand-based operation of Hoval indoor climate systems.

Intended use also includes compliance with the operating instructions. Any usage over and above this use is considered to be not as intended. The manufacturer can accept no liability for damage resulting from improper use.

1.2 User group

The units are only allowed to be installed, operated and maintained by authorised and instructed personnel who are well acquainted with the units and are informed about possible dangers.

The operating instructions are for operating engineers as well as specialists in building, heating and ventilation technology.

2 Construction and operation

2.1 Construction

The TopVent® THC unit consists of the following components:

- Fan unit: Diagonal fan with energy-saving EC motor, maintenance-free and infinitely variable
- Heating section: Contains the heating coil for heating the supply air with hot water
- Cooling section: Contains the cooling coil for cooling the supply air with cold water and the condensate separator for the condensate generated
- Air-Injector: The Air-Injector is a patented, infinitely variable vortex air distributor for the draught-free introduction of air into the hall under changing operating conditions.

As part of the TopTronic® C control system, the unit control box is an integral component.

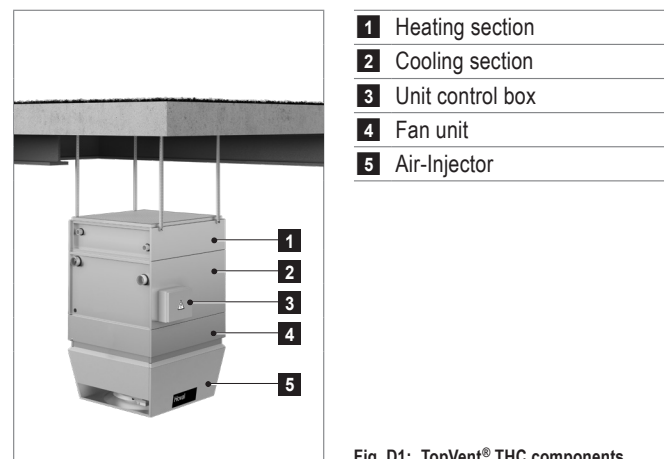
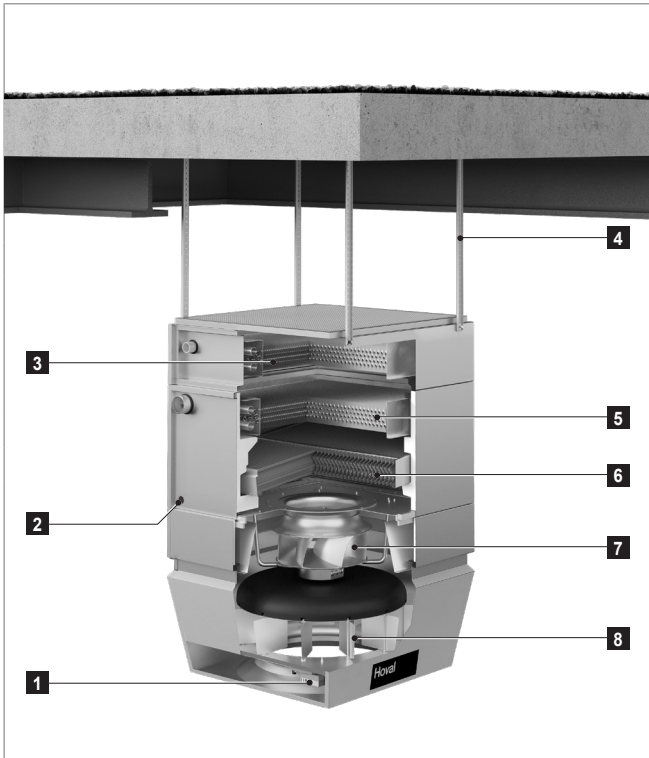

Fig. D1: TopVent® THC components



- 1 Actuator Air-Injector
- 2 Condensate connection
- 3 Heating coil
- 4 Suspension set
- 5 Cooling coil
- 6 Condensate separator
- 7 Fan
- 8 Air-Injector

Fig. D2: TopVent® THC structure

2.2 Function diagram

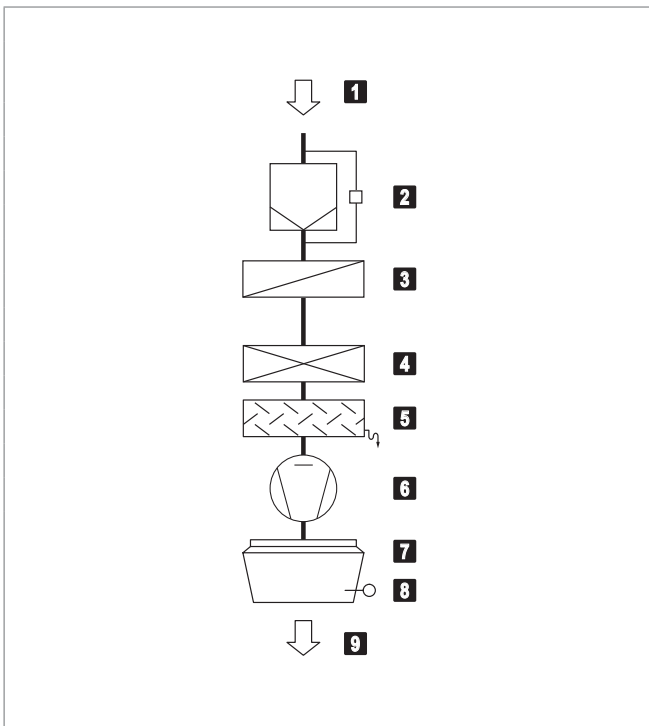

- 1 Extract air
- 2 Air filter with differential pressure switch (option)
- 3 Heating coil
- 4 Cooling coil
- 5 Condensate separator
- 6 Fan
- 7 Air-Injector with actuator
- 8 Supply air temperature sensor
- 9 Supply air

Fig. D3: TopVent® THC function diagram

2.3 Operating modes

The TopVent® THC has the following operating modes:

- Recirculation
- Recirculation speed 1
- Standby

The TopTronic® C control system regulates these operating modes automatically for each control zone in accordance with the specifications in the calendar.

The following points also apply:

- The operating mode of a control zone can be switched over manually.
- Each TopVent® THC unit can operate individually in a local operating mode: Off, Recirculation, Recirculation speed 1.

Code	Operating mode	Description
REC	Recirculation On/Off operation: during heat or cool demand, the unit draws in room air, heats or cools it and blows it back into the room. The room temperature set value day is active.	Fan speed 1 / 2 ¹⁾ Heating/cooling on ¹⁾ Depending on heat or cool demand
DES	■ Destratification: To avoid heat build-up under the ceiling, it may be appropriate to switch on the fan when there is no heat or cool demand (either in permanent operation or in on/off operation depending on the temperature stratification, as desired).	Fan speed 2 Heating/cooling off
REC1	Recirculation speed 1 The same as REC, but the unit operates only at speed 1 (low air flow rate)	Fan speed 1 ¹⁾ Heating/cooling on ¹⁾ Depending on heat or cool demand
DES	■ Destratification: The same as for REC, but the unit operates only at speed 1	Fan speed 1 Heating/cooling off
ST	Standby The unit is ready for operation. The following operating modes are activated if required:	
CPR	■ Cooling protection: If the room temperature drops below the set value for cooling protection, the unit heats up the room in recirculation operation.	Fan speed 2 Heating on
OPR	■ Overheating protection: If the room temperature rises above the set value for overheating protection, the unit cools down the room in recirculation operation.	Fan speed 2 Cooling..... on
L_OFF	Off (local operating mode) The unit is switched off.	Fan off Heating/cooling off
-	Forced heating The unit draws in room air, warms it and blows it back into the room. Forced heating is activated by connecting the unit to a power supply (only if there is no bus connection to the zone controller). For example, it is suitable for heating the hall before taking the control system into operation or if the controller fails during the heating period.	Fan speed 2 Heating on

Table D1: TopVent® THC operating modes

3 Technical data

3.1 Type code

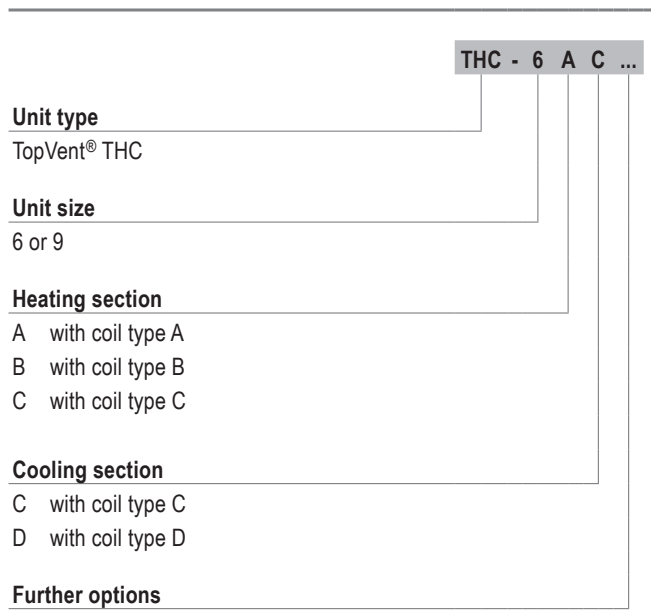

Table D2: TopVent® THC type code

3.2 Application limits

Extract air temperature	max.	°C	50
Supply air temperature	max.	°C	60
Temperature of the heating medium ¹⁾	max.	°C	90
Pressure of the heating medium	max.	kPa	800
Air flow rate	Size 6:	min.	m³/h 3100
	Size 9:	min.	m³/h 5000
Condensate quantity	Size 6:	max.	kg/h 90
	Size 9:	max.	kg/h 150

The units cannot be used in:

- Damp locations
- Places with a corrosive or aggressive environment
- Spaces with a large amount of dust
- Areas where there is danger of explosion

¹⁾ Design for higher temperatures on request

Table D3: TopVent® THC application limits

3.3 Electrical connection

Unit type		THC-6	THC-9
Supply voltage	V AC	3 × 400	3 × 400
Permitted voltage tolerance	%	± 5	± 5
Frequency	Hz	50	50
Connected load	kW	3.6	3.6
Current consumption max.	A	5.9	5.9
Series fuse	A	13	13
Protection rating	-	IP 54	IP 54

Table D4: TopVent® THC electrical connections

3.4 Air flow rate

Unit type		THC-6	THC-9
Nominal air flow rate	m³/h	6000	9000
Floor area covered	m²	537	946

Table D5: TopVent® THC air flow rate

3.5 Sound level

Unit type		THC-6CC	THC-9CC
Sound pressure level (at a distance of 5 m) ¹⁾	dB(A)	54	60
Total sound power level	dB(A)	76	82
Octave sound power level	63 Hz	dB 41	47
	125 Hz	dB 59	66
	250 Hz	dB 62	69
	500 Hz	dB 68	74
	1000 Hz	dB 71	77
	2000 Hz	dB 71	76
	4000 Hz	dB 67	74
	8000 Hz	dB 58	67

¹⁾ with a hemispherical radiation pattern in a low-reflection room

Table D6: TopVent® THC sound level

3.6 Heat output

Heating medium temperature			80/60 °C					60/40 °C				
Size	Type	t _{room} °C	Q kW	H _{max} m	t _s °C	Δp _w kPa	m _w l/h	Q kW	H _{max} m	t _s °C	Δp _w kPa	m _w l/h
THC-6	A	16	32.8	13.4	34.2	7	1410	18.8	16.8	27.3	2	807
		20	30.3	14.0	37.0	6	1301	16.2	17.9	30.0	2	697
	B	16	47.0	11.6	41.3	13	2020	26.9	14.6	31.3	4	1157
		20	43.4	12.0	43.5	11	1864	23.3	15.5	33.5	3	1001
	C	16	76.0	9.4	55.6	18	3267	45.0	11.8	40.3	6	1935
		20	70.3	9.8	56.8	16	3022	39.3	12.5	41.5	5	1690
THC-9	A	16	55.5	13.6	36.3	8	2386	31.7	17.0	28.5	3	1364
		20	51.2	14.1	38.9	7	2201	27.4	18.1	31.1	2	1179
	B	16	71.2	12.2	41.5	12	3060	40.6	15.4	31.4	4	1746
		20	65.7	12.7	43.7	10	2823	35.1	16.5	33.6	3	1509
	C	16	117.9	9.8	56.9	18	5066	69.9	12.3	41.1	6	3003
		20	109.1	10.2	58.0	15	4686	61.0	13.1	42.1	5	2622

Legend: Type = Type of coil t_s = Supply air temperature
t_{room} = Room air temperature Δp_w = Water pressure drop
Q = Heat output m_w = Water quantity
H_{max} = Maximum mounting height

Reference: ■ At room air temperature 16 °C: extract air temperature 18 °C
■ At room air temperature 20 °C: extract air temperature 22 °C

Table D7: TopVent® THC heat output

3.7 Cooling capacity

Cooling medium temperature				6/12 °C						8/14 °C					
Size	Type	t _{room} °C	RH _{room} %	Q _{sen} kW	Q _{tot} kW	t _s °C	Δp _w kPa	m _w l/h	m _c kg/h	Q _{sen} kW	Q _{tot} kW	t _s °C	Δp _w kPa	m _w l/h	m _c kg/h
THC-6	C	22	50	20.4	20.4	13.9	15	2925	0.0	20.4	20.4	13.9	15	2925	0.0
			70	18.5	27.7	14.9	28	3960	13.5	16.0	21.4	16.1	17	3064	7.9
		26	50	25.2	31.1	15.5	36	4448	8.6	22.7	24.8	16.7	23	3552	3.0
			70	23.2	43.7	16.5	71	6263	30.2	20.8	37.5	17.7	52	5367	24.6
THC-9	C	22	50	31.4	31.4	13.6	15	4496	0.0	31.4	31.4	13.6	15	4496	0.0
			70	28.4	44.7	14.6	31	6401	23.9	24.6	28.2	15.9	12	4031	5.2
		26	50	38.8	49.9	15.2	38	7149	16.3	35.0	35.0	16.4	19	5013	0.0
			70	35.9	69.8	16.2	75	9989	49.8	32.0	53.2	17.4	44	7619	31.1
	D	22	50	37.1	37.1	11.8	13	5307	0.0	37.1	37.1	11.8	13	5307	0.0
			70	34.6	56.7	12.6	30	8118	32.5	29.7	45.1	14.2	19	6459	22.6
		26	50	46.4	62.4	12.7	36	8941	23.5	41.6	50.9	14.3	24	7282	13.6
			70	43.9	87.4	13.5	70	12513	63.9	39.1	75.8	15.1	53	10854	54.0

Legend: Type = Type of coil t_s = Supply air temperature
t_{room} = Room air temperature Δp_w = Water pressure drop
RH_{room} = Relative humidity of the room air m_w = Water quantity
Q_{sen} = Sensible cooling capacity m_c = Condensate quantity
Q_{tot} = Total cooling capacity

Reference: ■ At room air temperature 22 °C: extract air temperature 24 °C
■ At room air temperature 26 °C: extract air temperature 28 °C

Table D8: TopVent® THC cooling capacity

3.8 Product information according to ErP

Model	TopVent® THC									Unit
	6-AC	6-BC	6-CC	9-AC	9-BC	9-CC	9-AD	9-BD	9-CD	
Cooling capacity (sensible) ($P_{rated,c}$)	26.5	26.5	26.5	41.0	41.0	41.0	48.6	48.6	48.6	kW
Cooling capacity (latent) ($P_{rated,c}$)	5.6	5.6	5.6	7.3	7.3	7.3	15.2	15.2	15.2	kW
Heating capacity ($P_{rated,h}$)	13.2	18.9	29.8	22.6	28.5	46.2	22.6	28.5	46.2	kW
Total electric power input (P_{elec})	0.72	0.76	0.87	1.37	1.49	1.42	1.54	1.56	1.68	kW
Sound power level (L_{WA})	74	75	76	81	81	82	82	82	82	dB
Contact details	Hoval Aktiengesellschaft Austrasse 70, 9490 Vaduz, Liechtenstein www.hoval.com									

Table D9: Product information according to Commission Regulation (EU) 2016/2281, Table 13

3.9 Dimensions and weights

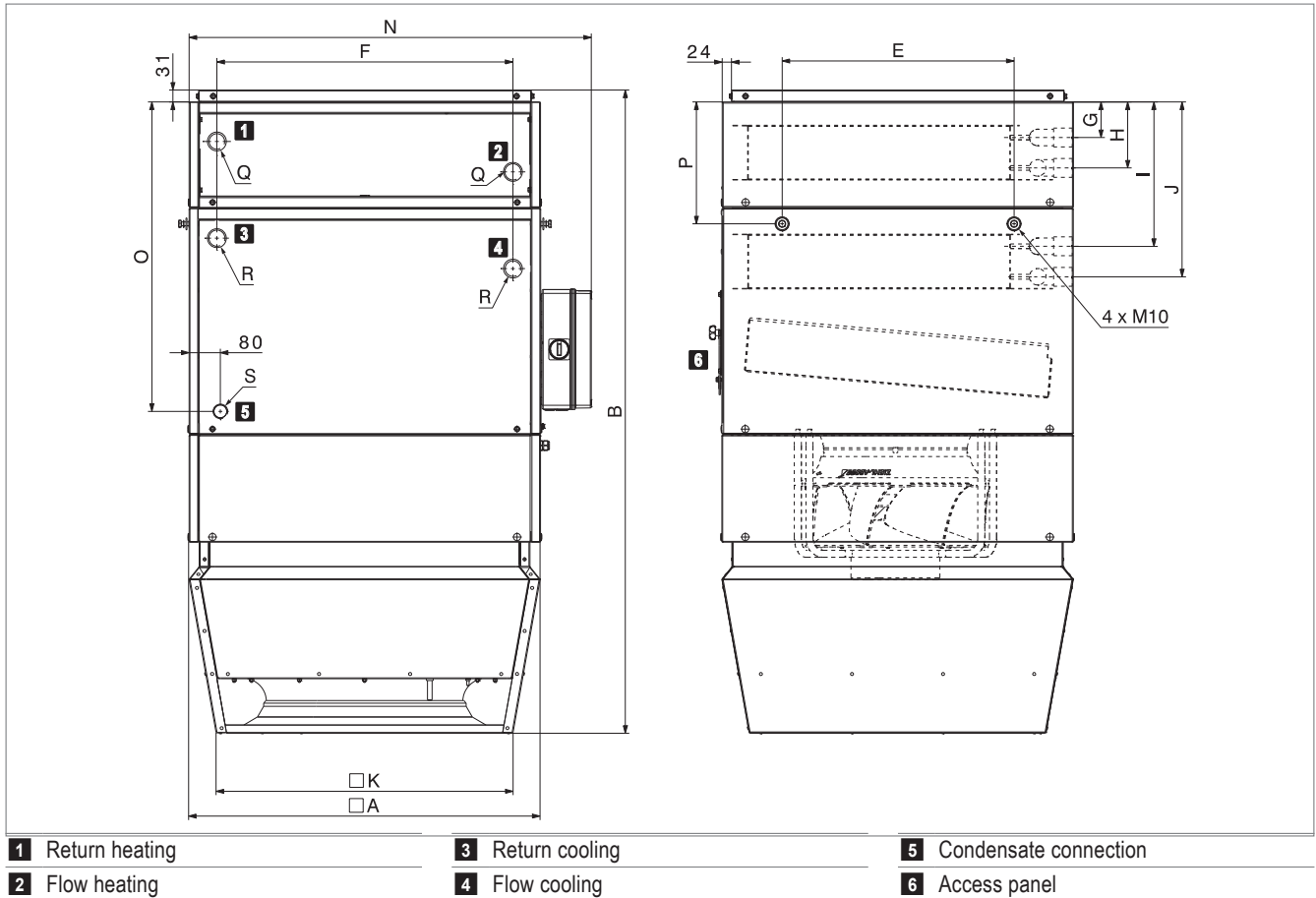

Fig. D4: TopVent® THC dimensional drawing

Unit size		THC-6			THC-9			THC-9		
Coil type		AC	BC	CC	AC	BC	CC	AD	BD	CD
A	mm			900			1100			1100
B	mm			1647			1765			1765
E	mm			594			846			846
F	mm			758			882			882
G	mm			101			111			111
H	mm			179			189			189
I	mm			349			395			386
J	mm			427			473			481
K	mm			760			935			935
N	mm			1030			1230			1230
O	mm			792			860			860
P	mm			312			342			342
Q	"	Rp 1¼ (internal)			Rp 1½ (internal)			Rp 1½ (internal)		
R	"	Rp 1¼ (internal)			Rp 1½ (internal)			Rp 2 (internal)		
S	"	G 1 (external)			G 1 (external)			G 1 (external)		
Water content of heating coil	l	4.6	4.6	7.9	7.4	7.4	12.4	7.4	7.4	12.4
Water content of cooling coil	l	7.9	7.9	7.9	12.4	12.4	12.4	19.2	19.2	19.2
Weight	kg	248	248	255	318	318	329	329	329	340

Table D10: TopVent® THC dimensions and weights

4 Specification texts

4.1 TopVent® THC

Recirculation unit for heating and cooling rooms up to 25 m in height with central heat and cold supply (4-pipe system); equipped with highly efficient air distributor; maximum floor area reached per unit 537 m² (size 6) and 946 m² respectively (size 9).

The unit consists of the following components:

- Fan unit
- Heating section
- Cooling section
- Air-Injector
- Unit control box
- Optional components

TopVent® THC units comply with all the requirements of the Ecodesign Directive 2009/125/EC relating to environmentally friendly design of energy-related products. They are systems of the 'fan coil unit' type, provided for in Commission Regulation (EU) 2016/2281.

Fan unit

Consisting of radial fan with high-efficiency EC motor, backwards-curved, three-dimensional contoured blades and free-running rotor made of a high-performance composite material, aerodynamically optimised inflow nozzle, low-noise, with integrated overload protection (integrated in the cooling section).

Heating section

Housing made of aluzinc sheet, air-tight, flame retardant, hygienic and easy to maintain because of ageing-resistant, silicone-free sealing materials.

The heating section contains:

- The highly efficient heating coil consisting of seamless copper pipes with pressed-on, optimised and profiled aluminium fins and manifolds made of copper; for connection to the hot water supply

Cooling section

Housing made of aluzinc sheet, air-tight, flame retardant, hygienic and easy to maintain because of ageing-resistant, silicone-free sealing materials, internally insulated with close-pored polyurethane.

The cooling section contains:

- The highly efficient cooling coil consisting of seamless copper pipes with pressed-on, optimised and profiled

aluminium fins and manifolds made of copper; for connection to the cold water supply

- The pull-out condensate separator with collecting channel, made of high-quality corrosion-resistant material, with a downslope in all directions for rapid draining
- The condensate trap for connecting to a condensate drain (supplied).

Air-Injector

Housing made of aluzinc sheet, air-tight, flame retardant, hygienic and easy to maintain because of ageing-resistant, silicone-free sealing materials, internally insulated with close-pored polyurethane, with:

- Vortex air distributor with concentric outlet nozzle, adjustable vanes and integrated absorber hood
- Actuator for infinitely variable adjustment of the air distribution from vertical to horizontal
 - for draught-free air distribution in the hall under changing operating conditions
 - for the rapid and large-area reduction of temperature stratification in the room through induction of secondary air and strong mixing of the room air with supply air
- Supply air temperature sensor

Unit control box

Control box fitted at the side of the unit for connection of the power supply and housing the control components that facilitate energy-optimised operation, controlled by the control system TopTronic® C. Plastic casing, protection rating IP 56. The following components are installed:

- Isolation switch
- Circuit board with all required electrical components, unit controller (clipped on) as well as connection terminals for the following external connections:
 - Heating/cooling valve
 - Heating/cooling pump
 - Return temperature sensor
 - Condensate pump

The circuit board is fitted with push-in terminals facilitating easy installation of the connection cables. All components in the unit control box as well as sensors and actuators in the unit are fully factory-wired.

Power supply and bus connection to be installed on site.

Options for the unit

Suspension set:

for ceiling installation of the unit consisting of 4 pairs U-profiles made of aluzinc sheet steel, height-adjustable to 1300 mm.

Filter box:

Housing made of aluzinc sheet with 2 ISO coarse 60% bag filters (G4), with differential pressure switch for filter monitoring, factory-wired to the circuit board in the unit control box.

Flat filter box:

Housing made of aluzinc sheet with 4 pleated ISO coarse 60% cell filters (G4), with differential pressure switch for filter monitoring, factory-wired to the circuit board in the unit control box.

Standard paint finish:

Exterior painting in Hoval red (RAL 3000), including optional components and suspension set

Paint finish as desired:

Exterior painting of the unit in choice of RAL colour, including optional components and suspension set

Recirculation silencer:

as an attachment to the unit, made of aluzinc sheet metal, lined with sound insulation matting, insertion attenuation 3 dB

Hydraulic assembly diverting system:

Prefabricated assembly for hydraulic diverting system, consisting of mixing valve, regulating valve, ball valve, automatic air vent and screw connections for connection to the unit and to the distributor circuit; mixing valve with plug-in connection, sized for the coil in the unit and the Hoval TopTronic® C control system.

Mixing valve:

Mixing valve with modulating rotary actuator and plug-in connection, sized for the coil in the unit.

Condensate pump:

Consisting of a centrifugal pump and a drip tray, max. delivery rate of 150 l/h with a delivery head of 3 m. Condensate pump with connection cable enclosed.

Pump control for mixing or injection system:

Electrical components for controlling a mixing or injection circuit in the load circuit, factory-installed in the unit control box.

4.2 TopTronic® C – System control

Zone-based control system for the energy-optimised operation of decentralised Hoval indoor climate systems. Maximum system size per system bus: 64 control zones with up to 10 supply and extract air handling units or supply air handling units and 10 recirculation air handling units each.

Zone allocation

Configured in advance for the customer at the factory:

	Room designation	Unit type
Zone 1:	_____	_____
Zone 2:	_____	_____
...		

System structure:

- Zone control panel made of coated sheet steel (light grey RAL 7035), ... x ... x ... mm, with:
 - System operator terminal
 - Fresh air temperature sensor
 - 1 zone controller and 1 room temperature sensor per zone (expandable to up to 4 room temperature sensors per zone)
 - Safety relay
 - Electrical cabinet internally pre-wired, all components routed to terminals
- Zone bus: as serial bus for communication with all controllers in one control zone, with robust bus protocol via shielded, twisted bus cable (provided by the client)
- Unit controller: installed in the particular indoor climate unit, works autonomously according to the specifications of the zone controller
- Heating/cooling demand per zone with feedback monitoring

Functions, standard

- Zone-based autonomous room control. Temperature and ventilation control separately adjustable for each zone
- Room temperature control via room-supply air cascade by means of energy-optimised double sequence control with priority circuit for energy recovery (supply and extract air handling units)
- Intelligent automatic heating to reach the desired room temperature at the switching time
- 5 adjustable room temperature set values per zone:
 - Cooling protection (lower setpoint in standby)
 - Overheating protection (upper setpoint in standby)
 - Room set value winter
 - Room set value summer
 - Night cooling set value (free cooling) (supply and extract air handling units)
- Destratification mode for even temperature distribution

- Main operating modes of supply and extract air handling units:

VE Ventilation, infinitely variably adjustment

AQ.... Air quality, automatic control with Hoval combination sensor (option), optional reference variable:

- CO₂ or VOC
- Air humidity (optimised dehumidification mode)

REC . Recirculation, infinitely variably adjustment

DES.. Destratification

EA Exhaust air, infinitely variably adjustment

SA Supply air, infinitely variably adjustment

ST Standby

- Main operating modes of supply air units:

REC . Recirculation, infinitely variably adjustment

DES.. Destratification

SA Supply air, infinitely variably adjustment

ST Standby

- Main operating modes of recirculated air units:

REC . Recirculation, infinitely variably adjustment

DES.. Destratification

ST Standby

- Forced heating (construction site heating) can be activated on each device before completion of the overall system (activation by Hoval service technician)
- Control of draught-free air distribution with the Hoval Air-Injector: the discharge direction is adjusted infinitely variably and automatically according to the respective operating condition and the existing temperatures (heating/cooling).

Operation

- TopTronic® C-ST system operator terminal: touch panel for visualisation and control of all Hoval indoor climate units registered on the bus

Options for operation

- Hoval C-SSR operating software, for visualisation on customer's PC
- TopTronic® C-ZT as zone operator terminal: for simple on-site operation of a control zone
- Manual operating selector switches
- Manual operating selector buttons
- Operating of the units via building management system via standardised interfaces:
 - BACnet
 - Modbus IP
 - Modbus RTU

Alarms, protection

- Central alarm management with registration of all alarms (timestamp, priority, status) in an alarm list and alarm memory of the last 50 alarms; forwarding via e-mail can be set in the parameters.
- If there is a failure of communication, bus stations, sensor systems or supply media, each part of the system transitions to a protection mode which safeguards operation.
- A maintenance mode implemented in the control algorithm for testing all physical data points and alarms guarantees high reliability.
- Pre-programmed data points retrievable via logger function for 1 year

Options for the zone control panel

- Alarm lamp
- Socket

Per zone

- The change-over between heating and cooling can be either automatic or manual
 - Cooling lock switch for automatic changeover
 - Heating/cooling switch for manual changeover
- Additional room air temperature sensors (max. 3)
- Combination sensor room air quality, temperature and humidity
- Combination sensor fresh air temperature and humidity
- Transfer of actual values and setpoints from external systems (0...10 V; 4 - 20 mA)
- Load shedding input
- Operating selector switches on terminal
- Operating selector buttons on terminal
- Control of distributor pump, incl. power supply

Power distribution:

- Circuit breakers and output terminals for Hoval indoor climate units
- Safety relay (4-pin)

4.3 TopTronic® C – System control for TopVent® C-SYS

Control system for the energy-optimised operation of decentralised Hoval indoor climate systems. Maximum system size per system bus: 1 control zone with up to 6 supply air handling units and 10 recirculation air handling units.

System structure

- Zone control panel, designed as compact cabinet for wall installation, made of coated sheet steel (light grey RAL 7035), 380 × 300 × 210 mm, with:
 - Operating panel
 - Zone controller
 - Fresh air temperature sensor
 - 1 Room temperature sensor (expandable to up to 4 room temperature sensors)
 - Safety relay
 - Electrical cabinet internally pre-wired
- Zone bus: as serial bus for communication with all controllers in the control zone, with robust bus protocol via shielded, twisted bus cable (provided by the client)
- Unit controller: installed in the particular indoor climate unit, works autonomously according to the specifications of the zone controller
- Circuit board with external connections for:
 - Collective alarm
 - Forced off
 - Heating demand
 - Setpoint heating demand
 - Fault heat supply
 - Cooling demand
 - Fault cold supply
 - External enabling heating/cooling (for automatic changeover)
 - External setting heating/cooling (for manual changeover)
 - Changeover valves heating/cooling
 - Additional room air temperature sensors (max. 3)
 - External setpoint fresh air ratio
 - Operating selector switch on terminal (digital)
 - Operating selector button on terminal

Functions, standard

- Room temperature control via sequential control of the coils
- Intelligent automatic heating to reach the desired room temperature at the switching time
- 4 adjustable room temperature set values per zone:
 - Cooling protection (lower setpoint in standby)
 - Overheating protection (upper setpoint in standby)
 - Room set value winter
 - Room set value summer
- Destratification mode for even temperature distribution

- Main operating modes of supply air units:
 - REC . Recirculation, infinitely variably adjustment
 - DES.. Destratification
 - SA Supply air, infinitely variably adjustment
 - ST Standby
- Main operating modes of recirculated air units:
 - REC . Recirculation, infinitely variably adjustment
 - DES.. Destratification
 - ST Standby
- Forced heating (construction site heating) can be activated on each device before completion of the overall system (activation by Hoval service technician)
- Control of draught-free air distribution with the Hoval Air-Injector: the discharge direction is adjusted infinitely variably and automatically according to the respective operating condition and the existing temperatures (heating/cooling).

Operation

- Operating panel with LCD display, installed in the door of the zone control panel for visualisation and control of all Hoval indoor climate units registered on the bus

Options for operation

- Hoval C-SSR operating software, for visualisation on customer's PC
- Operating of the units via building management system via standardised interfaces:
 - BACnet
 - Modbus IP
 - Modbus RTU

Alarms, protection

- Central alarm management with registration of all alarms (timestamp, priority, status) in an alarm list and alarm memory of the last 50 alarms; forwarding via e-mail can be set in the parameters.
- If there is a failure of communication, bus stations, sensor systems or supply media, each part of the system transitions to a protection mode which safeguards operation.
- A maintenance mode implemented in the control algorithm for testing all physical data points and alarms guarantees high reliability.
- Pre-programmed data points retrievable via logger function for 1 year

Options for the zone control panel

- Additional room air temperature sensors (max. 3)



TopVent® MH

Supply air units for ventilating and heating spaces up to 25 m in height with central heat supply

1 Use	46
2 Construction and operation	46
3 Technical data	50
4 Specification texts	53

E

1 Use

1.1 Intended use

TopVent® MH units are supply air units for ventilating and heating spaces up to 25 m in height with central heat supply. They have the following functions:

- Heating (with connection to a hot water supply)
- Fresh air supply
- Mixed air operation
- Recirculation operation
- Air distribution and destratification with adjustable Air-Injector
- Air filtration

TopVent® MH units comply with all the requirements of the Ecodesign Directive 2009/125/EC relating to environmentally friendly design of energy-related products. It is a system of the 'fan coil unit' type.

The Hoval TopTronic® C integrated control system ensures energy-efficient, demand-based operation of Hoval indoor climate systems.

Intended use also includes compliance with the operating instructions. Any usage over and above this use is considered to be not as intended. The manufacturer can accept no liability for damage resulting from improper use.

1.2 User group

The units are only allowed to be installed, operated and maintained by authorised and instructed personnel who are well acquainted with the units and are informed about possible dangers.

The operating instructions are for operating engineers as well as specialists in building, heating and ventilation technology.

2 Construction and operation

2.1 Construction

The TopVent® MH unit consists of the following components:

- Fan unit:
Diagonal fan with energy-saving EC motor, maintenance-free and infinitely variable
- Heating section:
Contains the heating coil for heating the supply air with hot water
- Air-Injector:
The Air-Injector is a patented, infinitely variable vortex air distributor for the draught-free introduction of air into the hall under changing operating conditions.
- Filter box:
Contains 2 ISO Coarse 60 % bag filters (G4), easily accessible behind the sliding door
- Mixed air box:
Contains fresh air damper and recirculation damper linked to move in opposite directions and actuator with spring return

As part of the TopTronic® C control system, the unit control box is an integral component.

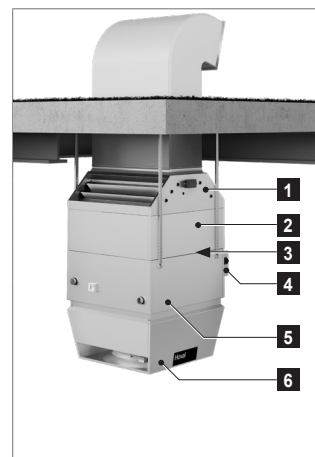

- | | |
|---|------------------|
| 1 | Mixed air box |
| 2 | Filter box |
| 3 | Fan unit |
| 4 | Unit control box |
| 5 | Heating section |
| 6 | Air-Injector |

Fig. E1: TopVent® MH components

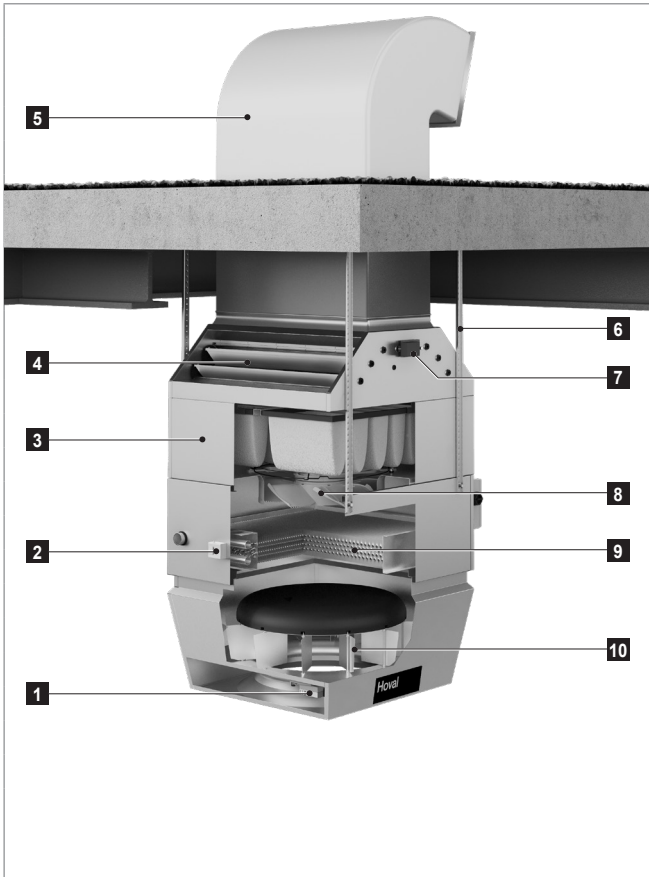

- 1 Actuator Air-Injector
- 2 Frost controller
- 3 Filter box
- 4 Mixed air box
- 5 Fresh air duct (field-supplied)
- 6 Suspension set
- 7 Fresh air damper actuator
- 8 Fan
- 9 Heating coil
- 10 Air-Injector

Fig. E2: TopVent® MH construction

2.2 Function diagram

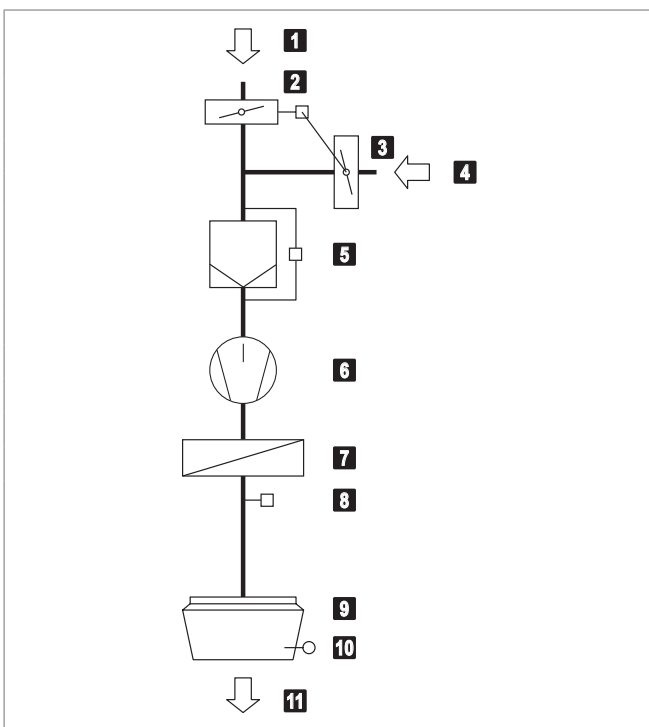

- 1 Fresh air
- 2 Fresh air damper with actuator
- 3 Recirculation damper (opposed to the fresh air damper)
- 4 Extract air
- 5 Air filter with differential pressure switch
- 6 Fan
- 7 Heating coil
- 8 Frost controller
- 9 Air-Injector with actuator
- 10 Supply air temperature sensor
- 11 Supply air

Fig. E3: TopVent® MH function diagram

2.3 Operating modes

The TopVent® MH operates in the following modes:

- Supply air speed 2
- Supply air speed 1
- Recirculation
- Recirculation speed 1
- Standby

The TopTronic® C control system regulates these operating modes automatically for each control zone in accordance with the specifications in the calendar.

The following points also apply:

- The operating mode of a control zone can be switched over manually.
- Each TopVent® MH unit can operate individually in a local operating mode:
Off, Supply air speed 2, Supply air speed 1, Recirculation, Recirculation speed 1.

Code	Operating mode	Description
SA2	Supply air speed 2 The unit blows fresh air into the room. The fresh air ratio is adjustable. The heating is regulated according to the heat demand. The room temperature set value day is active. The unit operates at speed 2 (high air flow rate).	Fan speed 2 Fresh air damper..... 10 % open ¹⁾ Heating on ²⁾ ¹⁾ Percentage is adjustable ²⁾ Depending on heat demand
SA1	Supply air speed 1 The same as SA2, but the unit operates at speed 1 (low air flow rate)	Fan speed 1 Fresh air damper..... 10 % open ¹⁾ Heating on ²⁾ ¹⁾ Percentage is adjustable ²⁾ Depending on heat demand
REC	Recirculation On/off-operation: if heating is required, the unit draws in room air, heats it and blows the warm air back into the room. The room temperature set value day is active.	Fan speed 1/2 ¹⁾ Fresh air damper..... closed Heating on ¹⁾ ¹⁾ Depending on heat demand
DES	■ Destratification: To avoid heat build-up under the ceiling, it may be appropriate to switch on the fan when there is no heat demand (either in permanent operation or in on/off operation depending on the temperature stratification, as desired).	Fan speed 2 Fresh air damper..... closed Heating off
REC1	Recirculation speed 1 The same as REC, but the unit operates only at speed 1 (low air flow rate)	Fan speed 1 Fresh air damper..... closed Heating on ¹⁾ ¹⁾ Depending on heat demand
DES	■ Destratification: The same as for REC, but the unit operates only at speed 1	Fan speed 1 Fresh air damper..... closed Heating off
ST	Standby The unit is ready for operation. The following operating modes are activated if required:	
CPR	■ Cooling protection: If the room temperature drops below the set value for cooling protection, the unit heats up the room in recirculation operation.	Fan speed 2 Fresh air damper..... closed Heating on

Code	Operating mode	Description
NCS	<ul style="list-style-type: none"> Night cooling: If the room temperature exceeds the set value for night cooling and the current fresh air temperature permits it, the unit blows cool fresh air into the room and extracts warmer room air. 	Fan speed 2 Fresh air damper..... open Heating off
L_OFF	Off (local operating mode) The unit is switched off. Frost protection for the unit remains active.	Fan off Fresh air damper..... closed Heating off
-	Forced heating The unit draws in room air, warms it and blows it back into the room. Forced heating can be activated and set as required by the Hoval service technician. For example, it is suitable for heating the hall before taking the control system into operation or if the controller fails during the heating period.	Fan speed 2 ¹⁾ Fresh air damper..... closed ¹⁾ Heating on ¹⁾ 1) Adjustable by the Hoval service technician

Table E1: TopVent® MH operating modes

3 Technical data

3.1 Type code

MH - 6 A - ...	
Unit type	TopVent® MH
Unit size	6 or 9
Heating section	A with coil type A B with coil type B C with coil type C
Further options	

Table E2: TopVent® MH type code

3.2 Application limits

Extract air temperature	max.	°C	50
Supply air temperature	max.	°C	60
Temperature of the heating medium ¹⁾	max.	°C	90
Pressure of the heating medium	max.	kPa	800
The units cannot be used in:			
<ul style="list-style-type: none"> ■ Damp locations ■ Places with a corrosive or aggressive environment ■ Spaces with a large amount of dust ■ Areas where there is danger of explosion 			
¹⁾ Design for higher temperatures on request			

Table E3: TopVent® MH application limits

3.3 Electrical connection

Unit type		MH-6	MH-9
Supply voltage	V AC	3 × 400	3 × 400
Permitted voltage tolerance	%	± 5	± 5
Frequency	Hz	50	50
Connected load	kW	1.5	2.1
Current consumption max.	A	2.9	4.0
Series fuse	A	13	13
Protection rating	-	IP 54	IP 54

Table E4: TopVent® MH electrical connection

3.4 Air flow rate

Unit type		MH-6	MH-9
Nominal air flow rate	m³/h	6000	9000
Floor area covered	m²	537	946

Table E5: TopVent® MH air flow rate

3.5 Sound level

Unit type		MH-6C	MH-9C	
Sound pressure level (at a distance of 5 m) ¹⁾	dB(A)	58	60	
Total sound power level	dB(A)	80	82	
Octave sound power level	63 Hz	dB	57	62
	125 Hz	dB	61	66
	250 Hz	dB	67	71
	500 Hz	dB	72	74
	1000 Hz	dB	76	77
	2000 Hz	dB	73	76
	4000 Hz	dB	67	71
	8000 Hz	dB	59	64

¹⁾ with a hemispherical radiation pattern in a low-reflection room

Table E6: TopVent® MH sound level

3.6 Heat output

Heating medium temperature			80/60 °C					60/40 °C				
Size	Type	t_F	Q	H_{max}	t_S	Δp_W	m_W	Q	H_{max}	t_S	Δp_W	m_W
		°C										
MH-6	A	- 5	33.1	14.4	33.9	7	1424	19.1	18.8	27.0	2	820
		-15	33.8	14.7	33.2	8	1451	19.7	19.5	26.3	3	848
	B	- 5	47.5	12.1	41.0	13	2040	27.4	15.7	31.1	4	1177
		-15	48.4	12.2	40.5	14	2079	28.3	16.1	30.5	5	1216
	C	- 5	76.8	9.7	55.5	18	3297	45.7	12.3	40.1	7	1965
		-15	78.2	9.7	55.2	19	3358	47.2	12.4	39.9	7	2026
MH-9	A	- 5	56.1	14.4	36.0	8	2409	32.3	18.8	28.2	3	1387
		-15	57.1	14.6	35.4	8	2455	33.4	19.4	27.5	3	1433
	B	- 5	71.9	12.8	41.2	12	3090	41.3	16.7	31.1	4	1775
		-15	73.3	12.9	40.7	13	3149	42.7	17.0	30.6	4	1834
	C	- 5	119.0	10.1	56.8	18	5113	71.0	12.9	40.9	7	3050
		-15	121.2	10.1	56.5	19	5208	73.2	12.9	40.7	7	3145
Legend:		Type = Type of coil			t_S = Supply air temperature							
		t_F = Fresh air temperature			Δp_W = Water pressure drop							
		Q = Heat output			m_W = Water quantity							
		H_{max} = Maximum mounting height										
Reference:		<ul style="list-style-type: none"> ■ Room air 18 °C, extract air 20 °C / 20 % rel. humidity ■ Fresh air ratio 10 % 										

Table E7: TopVent® MH heat output

3.7 Product information according to ErP

Model	TopVent® MH						Unit
	6 A	6B	6C	9 A	9B	9C	
Cooling capacity (sensible) ($P_{rated,c}$)	-	-	-	-	-	-	kW
Cooling capacity (latent) ($P_{rated,c}$)	-	-	-	-	-	-	kW
Heating capacity ($P_{rated,h}$)	13.2	18.9	29.8	22.6	28.5	46.2	kW
Total electric power input (P_{elec})	0.9	1.05	1.29	1.37	1.49	1.91	kW
Sound power level (L_{WA})	75	77	80	77	78	82	dB
Contact details	Hoval Aktiengesellschaft Austrasse 70, 9490 Vaduz, Liechtenstein www.hoval.com						

Table E8: Product information according to Commission Regulation (EU) 2016/2281, Table 13

3.8 Dimensions and weights

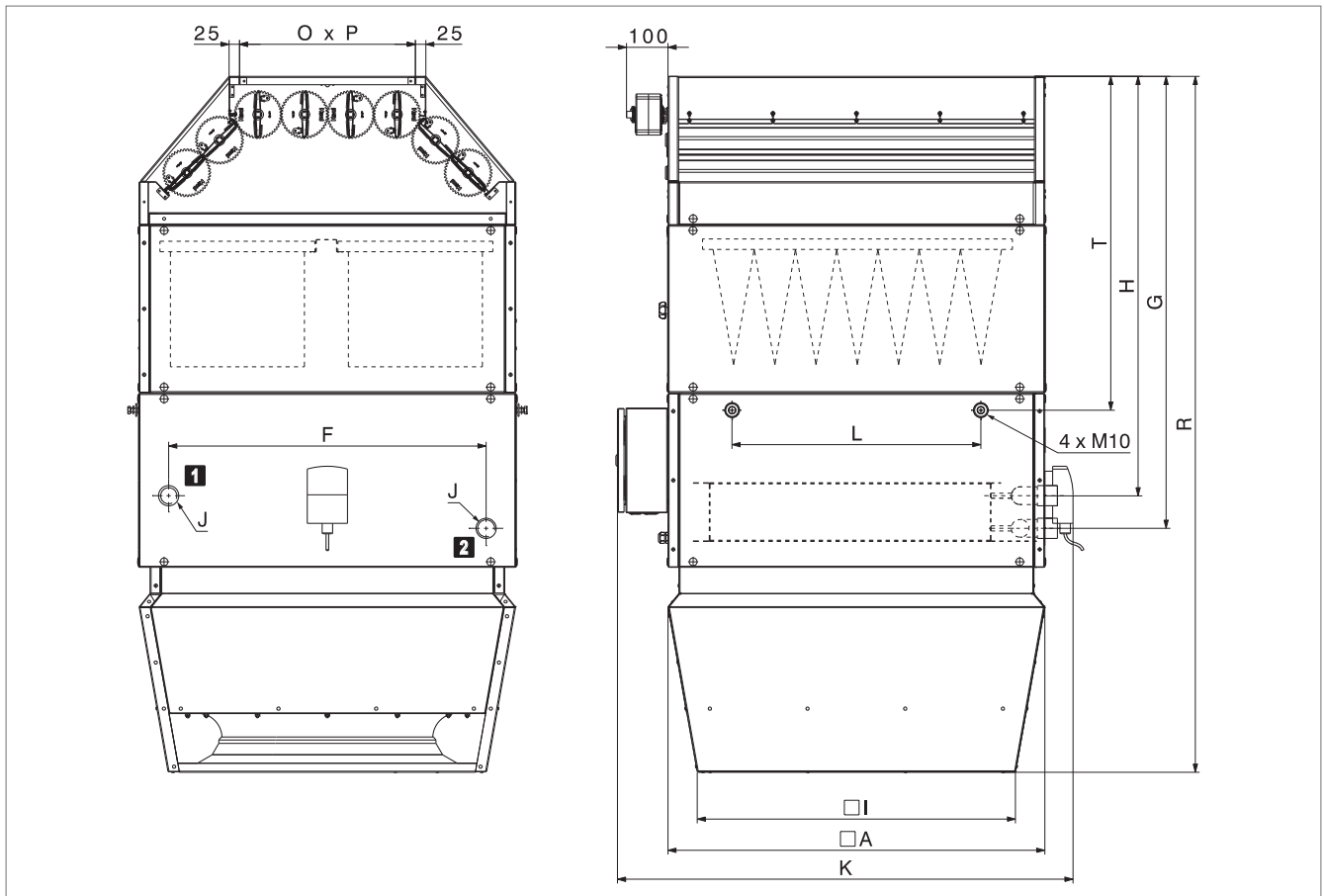

1 Return heating

2 Flow heating

Fig. E4: TopVent® MH dimensional drawing

Unit size		MH-6			MH-9		
		A	B	C	A	B	C
Coil type							
A	mm			900			1100
F	mm			758			882
G	mm			1077			1127
H	mm			999			1049
I	mm			760			935
K	mm			1089			1289
L	mm			594			846
O x P	mm		420 x 850		500 x 1050		
R	mm		1660				1810
T	mm		795				800
J	"		Rp 1¼ (internal)		Rp 1½ (internal)		
Water content of heating coil	l	4.6	4.6	7.9	7.4	7.4	12.4
Weight	kg	165	165	172	217	217	228

Table E9: TopVent® MH dimensions and weights

4 Specification texts

4.1 TopVent® MH

Supply air unit for heating rooms up to 25 m in height with central heat supply; equipped with highly efficient air distributor; maximum floor area reached per unit 537 m² (size 6) and 946 m² respectively (size 9).

The unit consists of the following components:

- Fan unit
- Heating section
- Air-Injector
- Filter box
- Mixed air box
- Unit control box
- Optional components

TopVent® MH units comply with all the requirements of the Ecodesign Directive 2009/125/EC relating to environmentally friendly design of energy-related products. They are systems of the 'fan coil unit' type, provided for in Commission Regulation (EU) 2016/2281.

Fan unit

Consisting of maintenance-free, direct-drive axial fan with high-efficiency EC motor and balanced rotating wheel with aerodynamically shaped blades and serrated trailing edge (integrated in the heating section).

Heating section

Housing made of aluzinc sheet, air-tight, flame retardant, hygienic and easy to maintain because of ageing-resistant, silicone-free sealing materials.

The heating section contains:

- The highly efficient heating coil consisting of seamless copper pipes with pressed-on, optimised and profiled aluminium fins and manifolds made of copper; for connection to the hot water supply

Air-Injector

Housing made of aluzinc sheet, air-tight, flame retardant, hygienic and easy to maintain because of ageing-resistant, silicone-free sealing materials, with:

- Vortex air distributor with concentric outlet nozzle, adjustable vanes and integrated absorber hood
- Actuator for infinitely variable adjustment of the air distribution from vertical to horizontal
 - for draught-free air distribution in the hall under changing operating conditions
 - for the rapid and large-area reduction of temperature stratification in the room through induction of secondary air and strong mixing of the room air with supply air
- Supply air temperature sensor

Filter box

Housing made of aluzinc sheet, internally insulated with EPDM, with 2 ISO coarse 60% bag filters (G4), with differential pressure switch for filter monitoring, factory-wired to the circuit board in the unit control box.

Mixed air box

Housing made of aluzinc sheet, internally insulated with EPDM, with fresh air damper and recirculation damper linked to move in opposite directions; includes actuator with spring return, factory-wired to the circuit board in the unit control box.

Unit control box

Control box fitted at the side of the unit for connection of the power supply and housing the control components that facilitate energy-optimised operation, controlled by the control system TopTronic® C. Housing made of coated sheet steel (light grey RAL 7035), protection rating IP 54. The following components are installed:

- Isolation switch
- Circuit board with all required electrical components, unit controller (clipped on) as well as connection terminals for the following external connections:
 - Heating valve
 - Heating pump
 - Return temperature sensor
 - Forced off

The circuit board is fitted with push-in terminals facilitating easy installation of the connection cables. All components in the unit control box as well as sensors and actuators in the unit are fully factory-wired.

Power supply and bus connection to be installed on site.

Options for the unit

Suspension set:

for ceiling installation of the unit consisting of 4 pairs U-profiles made of aluzinc sheet steel, height-adjustable to 1300 mm.

Standard paint finish:

Exterior painting in Hoval red (RAL 3000), including optional components and suspension set

Paint finish as desired:

Exterior painting of the unit in choice of RAL colour, including optional components and suspension set.

Acoustic cowl:

consisting of an absorber hood of large volume, insertion attenuation 4 dB

Hydraulic assembly diverting system:

Prefabricated assembly for hydraulic diverting system, consisting of mixing valve, regulating valve, ball valve, automatic air vent and screw connections for connection to the unit and to the distributor circuit; mixing valve with plug-in connection, sized for the coil in the unit and the Hoval TopTronic® C control system.

Mixing valve:

Mixing valve with modulating rotary actuator and plug-in connection, sized for the coil in the unit.

Pump control for mixing or injection system:

Electrical components for controlling a mixing or injection circuit in the load circuit, factory-installed in the unit control box.

Return temperature sensor:

Temperature sensor for monitoring the heating medium.

4.2 TopTronic® C – System control

Zone-based control system for the energy-optimised operation of decentralised Hoval indoor climate systems. Maximum system size per system bus: 64 control zones with up to 10 supply and extract air handling units or supply air handling units and 10 recirculation air handling units each.

Zone allocation

Configured in advance for the customer at the factory:

	Room designation	Unit type
Zone 1:	_____	_____
Zone 2:	_____	_____
...		

System structure:

- Zone control panel made of coated sheet steel (light grey RAL 7035), ... x ... x ... mm, with:
 - System operator terminal
 - Fresh air temperature sensor
 - 1 zone controller and 1 room temperature sensor per zone (expandable to up to 4 room temperature sensors per zone)
 - Safety relay
 - Electrical cabinet internally pre-wired, all components routed to terminals
- Zone bus: as serial bus for communication with all controllers in one control zone, with robust bus protocol via shielded, twisted bus cable (provided by the client)
- Unit controller: installed in the particular indoor climate unit, works autonomously according to the specifications of the zone controller
- Heating/cooling demand per zone with feedback monitoring

Functions, standard

- Zone-based autonomous room control. Temperature and ventilation control separately adjustable for each zone
- Room temperature control via room-supply air cascade by means of energy-optimised double sequence control with priority circuit for energy recovery (supply and extract air handling units)
- Intelligent automatic heating to reach the desired room temperature at the switching time
- 5 adjustable room temperature set values per zone:
 - Cooling protection (lower setpoint in standby)
 - Overheating protection (upper setpoint in standby)
 - Room set value winter
 - Room set value summer
 - Night cooling set value (free cooling) (supply and extract air handling units)
- Destratification mode for even temperature distribution

- Main operating modes of supply and extract air handling units:
 - VE Ventilation, infinitely variably adjustment
 - AQ.... Air quality, automatic control with Hoval combination sensor (option), optional reference variable:
 - CO₂ or VOC
 - Air humidity (optimised dehumidification mode)
 - REC . Recirculation, infinitely variably adjustment
 - DES.. Destratification
 - EA Exhaust air, infinitely variably adjustment
 - SA Supply air, infinitely variably adjustment
 - ST Standby
- Main operating modes of supply air units:
 - REC . Recirculation, infinitely variably adjustment
 - DES.. Destratification
 - SA Supply air, infinitely variably adjustment
 - ST Standby
- Main operating modes of recirculated air units:
 - REC . Recirculation, infinitely variably adjustment
 - DES.. Destratification
 - ST Standby
- Forced heating (construction site heating) can be activated on each device before completion of the overall system (activation by Hoval service technician)
- Control of draught-free air distribution with the Hoval Air-Injector: the discharge direction is adjusted infinitely variably and automatically according to the respective operating condition and the existing temperatures (heating/cooling).

Operation

- TopTronic® C-ST system operator terminal: touch panel for visualisation and control of all Hoval indoor climate units registered on the bus

Options for operation

- Hoval C-SSR operating software, for visualisation on customer's PC
- TopTronic® C-ZT as zone operator terminal: for simple on-site operation of a control zone
- Manual operating selector switches
- Manual operating selector buttons
- Operating of the units via building management system via standardised interfaces:
 - BACnet
 - Modbus IP
 - Modbus RTU

Alarms, protection

- Central alarm management with registration of all alarms (timestamp, priority, status) in an alarm list and alarm memory of the last 50 alarms; forwarding via e-mail can be set in the parameters.
- If there is a failure of communication, bus stations, sensor systems or supply media, each part of the system transitions to a protection mode which safeguards operation.
- A maintenance mode implemented in the control algorithm for testing all physical data points and alarms guarantees high reliability.
- Pre-programmed data points retrievable via logger function for 1 year

Options for the zone control panel

- Alarm lamp
- Socket

Per zone

- The change-over between heating and cooling can be either automatic or manual
 - Cooling lock switch for automatic changeover
 - Heating/cooling switch for manual changeover
- Additional room air temperature sensors (max. 3)
- Combination sensor room air quality, temperature and humidity
- Combination sensor fresh air temperature and humidity
- Transfer of actual values and setpoints from external systems (0...10 V; 4 - 20 mA)
- Load shedding input
- Operating selector switches on terminal
- Operating selector buttons on terminal
- Control of distributor pump, incl. power supply

Power distribution:

- Circuit breakers and output terminals for Hoval indoor climate units
- Safety relay (4-pin)

4.3 TopTronic® C – System control for TopVent® C-SYS

Control system for the energy-optimised operation of decentralised Hoval indoor climate systems. Maximum system size per system bus: 1 control zone with up to 6 supply air handling units and 10 recirculation air handling units.

System structure

- Zone control panel, designed as compact cabinet for wall installation, made of coated sheet steel (light grey RAL 7035), 380 × 300 × 210 mm, with:
 - Operating panel
 - Zone controller
 - Fresh air temperature sensor
 - 1 Room temperature sensor (expandable to up to 4 room temperature sensors)
 - Safety relay
 - Electrical cabinet internally pre-wired
- Zone bus: as serial bus for communication with all controllers in the control zone, with robust bus protocol via shielded, twisted bus cable (provided by the client)
- Unit controller: installed in the particular indoor climate unit, works autonomously according to the specifications of the zone controller
- Circuit board with external connections for:
 - Collective alarm
 - Forced off
 - Heating demand
 - Setpoint heating demand
 - Fault heat supply
 - Cooling demand
 - Fault cold supply
 - External enabling heating/cooling (for automatic changeover)
 - External setting heating/cooling (for manual changeover)
 - Changeover valves heating/cooling
 - Additional room air temperature sensors (max. 3)
 - External setpoint fresh air ratio
 - Operating selector switch on terminal (digital)
 - Operating selector button on terminal

Functions, standard

- Room temperature control via sequential control of the coils
- Intelligent automatic heating to reach the desired room temperature at the switching time
- 4 adjustable room temperature set values per zone:
 - Cooling protection (lower setpoint in standby)
 - Overheating protection (upper setpoint in standby)
 - Room set value winter
 - Room set value summer
- Destratification mode for even temperature distribution

- Main operating modes of supply air units:
 - REC . Recirculation, infinitely variably adjustment
 - DES.. Destratification
 - SA Supply air, infinitely variably adjustment
 - ST Standby
- Main operating modes of recirculated air units:
 - REC . Recirculation, infinitely variably adjustment
 - DES.. Destratification
 - ST Standby
- Forced heating (construction site heating) can be activated on each device before completion of the overall system (activation by Hoval service technician)
- Control of draught-free air distribution with the Hoval Air-Injector: the discharge direction is adjusted infinitely variably and automatically according to the respective operating condition and the existing temperatures (heating/cooling).

Operation

- Operating panel with LCD display, installed in the door of the zone control panel for visualisation and control of all Hoval indoor climate units registered on the bus

Options for operation

- Hoval C-SSR operating software, for visualisation on customer's PC
- Operating of the units via building management system via standardised interfaces:
 - BACnet
 - Modbus IP
 - Modbus RTU

Alarms, protection

- Central alarm management with registration of all alarms (timestamp, priority, status) in an alarm list and alarm memory of the last 50 alarms; forwarding via e-mail can be set in the parameters.
- If there is a failure of communication, bus stations, sensor systems or supply media, each part of the system transitions to a protection mode which safeguards operation.
- A maintenance mode implemented in the control algorithm for testing all physical data points and alarms guarantees high reliability.
- Pre-programmed data points retrievable via logger function for 1 year

Options for the zone control panel

- Additional room air temperature sensors (max. 3)



TopVent® MC

Supply air units for ventilating, heating and cooling spaces up to 25 m in height with central heat and cold supply (2-pipe-system)

1 Use	58
2 Construction and operation	58
3 Technical data	62
4 Specification texts	66

F

1 Use

1.1 Intended use

TopVent® MC units are supply air units for ventilating, heating and cooling spaces up to 25 m in height with central heat and cold supply. They have the following functions:

- Heating (with connection to a hot water supply)
- Cooling (with connection to a water chiller)
- Fresh air supply
- Mixed air operation
- Recirculation operation
- Air distribution and destratification with adjustable Air-Injector
- Air filtration

TopVent® MC units comply with all the requirements of the Ecodesign Directive 2009/125/EC relating to environmentally friendly design of energy-related products. It is a system of the 'fan coil unit' type.

The Hoval TopTronic® C integrated control system ensures energy-efficient, demand-based operation of Hoval indoor climate systems.

Intended use also includes compliance with the operating instructions. Any usage over and above this use is considered to be not as intended. The manufacturer can accept no liability for damage resulting from improper use.

1.2 User group

The units are only allowed to be installed, operated and maintained by authorised and instructed personnel who are well acquainted with the units and are informed about possible dangers.

The operating instructions are for operating engineers as well as specialists in building, heating and ventilation technology.

2 Construction and operation

2.1 Construction

The TopVent® MC unit consists of the following components:

- Fan unit:
Diagonal fan with energy-saving EC motor, maintenance-free and infinitely variable
- Heating/cooling section:
Contains the heating/cooling coil for heating and cooling the supply air with hot water or cold water and the condensate separator for the condensate generated
- Air-Injector:
The Air-Injector is a patented, infinitely variable vortex air distributor for the draught-free introduction of air into the hall under changing operating conditions.
- Filter box:
Contains 2 ISO Coarse 60 % bag filters (G4), easily accessible behind the sliding door
- Mixed air box:
Contains fresh air damper and recirculation damper linked to move in opposite directions and actuator with spring return

As part of the TopTronic® C control system, the unit control box is an integral component.

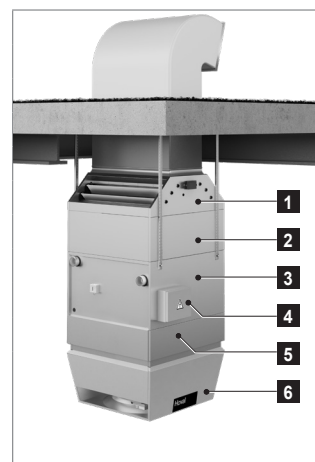

- | | |
|---|-------------------------|
| 1 | Mixed air box |
| 2 | Filter box |
| 3 | Heating/cooling section |
| 4 | Unit control box |
| 5 | Fan unit |
| 6 | Air-Injector |

Fig. F1: TopVent® MC components

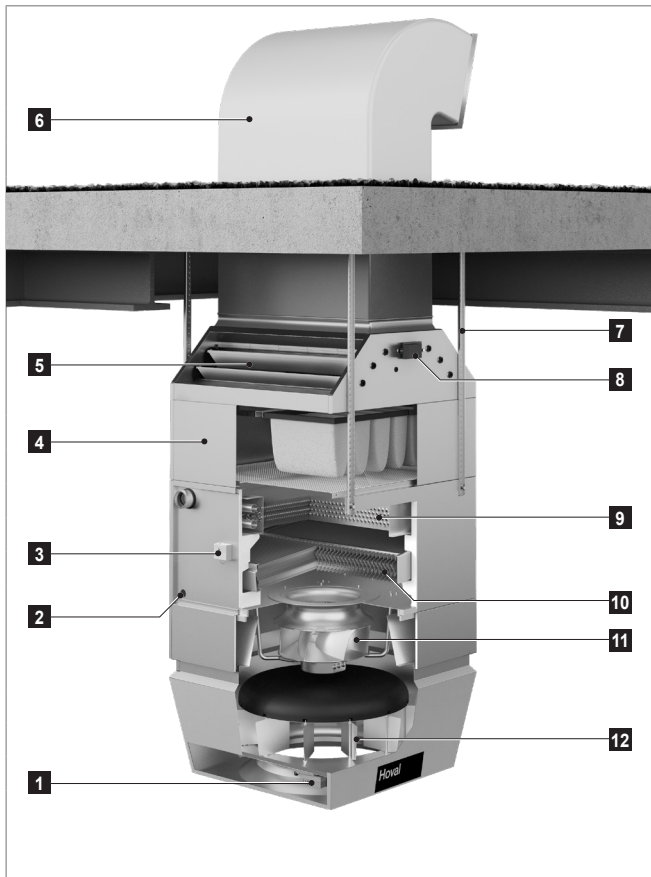

- 1 Actuator Air-Injector
- 2 Condensate connection
- 3 Frost controller
- 4 Filter box
- 5 Mixed air box
- 6 Fresh air duct (field-supplied)
- 7 Suspension set
- 8 Fresh air damper actuator
- 9 Heating/cooling coil
- 10 Condensate separator
- 11 Fan
- 12 Air-Injector

Fig. F2: TopVent® MC construction

2.2 Function diagram

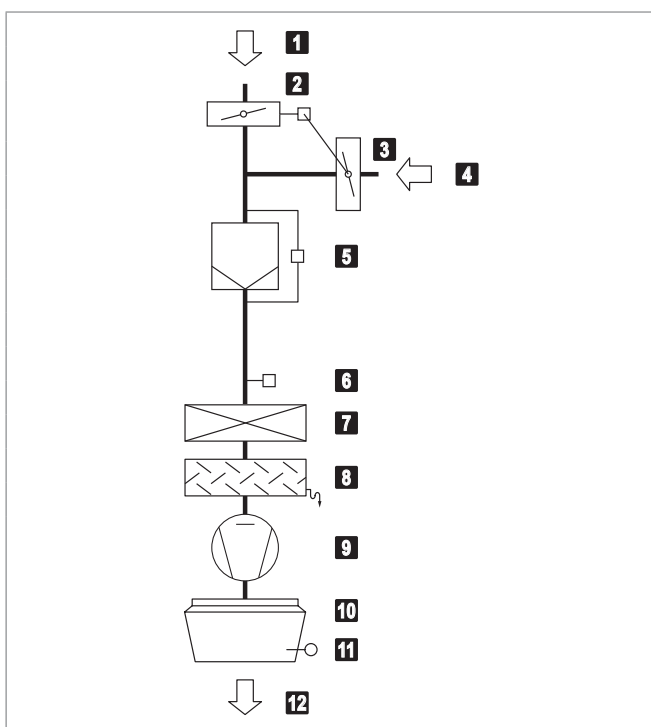

- 1 Fresh air
- 2 Fresh air damper with actuator
- 3 Recirculation damper (opposed to the fresh air damper)
- 4 Extract air
- 5 Air filter with differential pressure switch
- 6 Frost controller
- 7 Heating/cooling coil
- 8 Condensate separator
- 9 Fan
- 10 Air-Injector with actuator
- 11 Supply air temperature sensor
- 12 Supply air

Fig. F3: TopVent® MC function diagram

2.3 Operating modes

The TopVent® MC has the following operating modes:

- Supply air speed 2 ■ Recirculation
- Supply air speed 1 ■ Recirculation speed 1
- Standby

The TopTronic® C control system regulates these operating modes automatically for each control zone in accordance with the specifications in the calendar.

The following points also apply:

- The operating mode of a control zone can be switched over manually.
- Each TopVent® MC unit can operate individually in a local operating mode:
Off, Supply air speed 2, Supply air speed 1, Recirculation, Recirculation speed 1.

Code	Operating mode	Description
SA2	Supply air speed 2 The unit blows fresh air into the room. The fresh air ratio is adjustable. Heating/cooling is controlled according to the heat/cool demand. The room temperature set value day is active. The unit operates at speed 2 (high air flow rate).	Fan speed 2 Fresh air damper..... 10 % open ¹⁾ Heating/cooling on ²⁾ ¹⁾ Percentage is adjustable ²⁾ Depending on heat or cool demand
SA1	Supply air speed 1 The same as SA2, but the unit operates at speed 1 (low air flow rate)	Fan speed 1 Fresh air damper..... 10 % open ¹⁾ Heating/cooling on ²⁾ ¹⁾ Percentage is adjustable ²⁾ Depending on heat or cool demand
REC	Recirculation On/Off operation: during heat or cool demand, the unit draws in room air, heats or cools it and blows it back into the room. The room temperature set value day is active.	Fan speed 1/2 ¹⁾ Fresh air damper..... closed Heating/cooling on ¹⁾ ¹⁾ Depending on heat or cool demand
DES	■ Destratification: To avoid heat build-up under the ceiling, it may be appropriate to switch on the fan when there is no heat or cool demand (either in permanent operation or in on/off operation depending on the temperature stratification, as desired).	Fan speed 2 Fresh air damper..... closed Heating/cooling off
REC1	Recirculation speed 1 The same as REC, but the unit operates only at speed 1 (low air flow rate)	Fan speed 1 Fresh air damper..... closed Heating/cooling on ¹⁾ ¹⁾ Depending on heat or cool demand
DES	■ Destratification: The same as for REC, but the unit operates only at speed 1	Fan speed 1 Fresh air damper..... closed Heating/cooling off
ST	Standby The unit is ready for operation. The following operating modes are activated if required:	
CPR	■ Cooling protection: If the room temperature drops below the set value for cooling protection, the unit heats up the room in recirculation operation.	Fan speed 2 Fresh air damper..... closed Heating on
OPR	■ Overheating protection: If the room temperature rises above the set value for overheating protection, the unit cools down the room in recirculation operation.	Fan speed 2 Fresh air damper..... closed Cooling..... on

Code	Operating mode	Description
NCS	<ul style="list-style-type: none"> Night cooling: If the room temperature exceeds the set value for night cooling and the current fresh air temperature permits it, the unit blows cool fresh air into the room and extracts warmer room air. 	Fan speed 2 Fresh air damper..... open Heating/cooling off
L_OFF	Off (local operating mode) The unit is switched off. Frost protection for the unit remains active.	Fan off Fresh air damper..... closed Heating/cooling off
–	Forced heating The unit draws in room air, warms it and blows it back into the room. Forced heating can be activated and set as required by the Hoval service technician. For example, it is suitable for heating the hall before taking the control system into operation or if the controller fails during the heating period.	Fan speed 2 ¹⁾ Fresh air damper..... closed ¹⁾ Heating on ¹⁾ 1) Adjustable by the Hoval service technician

Table F1: TopVent® MC operating modes

3 Technical data

3.1 Type code

	MC - 6 - C ...
Unit type	TopVent® MC
Unit size	6 or 9
Heating/cooling section	C with coil type C D with coil type D
Further options	

Table F2: TopVent® MC type code

3.2 Application limits

Extract air temperature	max.	°C	50
Supply air temperature	max.	°C	60
Temperature of the heating medium ¹⁾	max.	°C	90
Pressure of the heating medium	max.	kPa	800
Air flow rate	Size 6:	min.	m³/h 3100
	Size 9:	min.	m³/h 5000
Condensate quantity	Size 6:	max.	kg/h 90
	Size 9:	max.	kg/h 150
The units cannot be used in:			
<ul style="list-style-type: none"> ■ Damp locations ■ Places with a corrosive or aggressive environment ■ Spaces with a large amount of dust ■ Areas where there is danger of explosion 			
¹⁾ Design for higher temperatures on request			

Table F3: TopVent® MC application limits

3.3 Electrical connection

Unit type		MC-6	MC-9
Supply voltage	V AC	3 × 400	3 × 400
Permitted voltage tolerance	%	± 5	± 5
Frequency	Hz	50	50
Connected load	kW	3.6	3.6
Current consumption max.	A	5.9	5.9
Series fuse	A	13	13
Protection rating	-	IP 54	IP 54

Table F4: TopVent® MC electrical connection

3.4 Air flow rate

Unit type		MC-6	MC-9
Nominal air flow rate	m³/h	6000	9000
Floor area covered	m²	537	946

Table F5: TopVent® MC air flow rate

3.5 Sound level

Unit type		MC-6-C	MC-9-C
Sound pressure level (at a distance of 5 m) ¹⁾	dB(A)	52	59
Total sound power level	dB(A)	74	81
Octave sound power level	63 Hz	dB	42
	125 Hz	dB	60
	250 Hz	dB	63
	500 Hz	dB	66
	1000 Hz	dB	68
	2000 Hz	dB	68
	4000 Hz	dB	67
8000 Hz	dB	62	

¹⁾ with a hemispherical radiation pattern in a low-reflection room

Table F6: TopVent® MC sound level

3.6 Heat output

Heating medium temperature		80/60 °C						60/40 °C				
Size	Type	t _F	Q	H _{max}	t _S	Δp _W	m _W	Q	H _{max}	t _S	Δp _W	m _W
		°C	kW	m	°C	kPa	l/h	kW	m	°C	kPa	l/h
MC-6	C	- 5	76.8	9.7	55.5	18	3297	45.7	12.3	40.1	7	1965
		-15	78.2	9.7	55.2	19	3358	47.2	12.4	39.9	7	2026
MC-9	C	- 5	119.0	10.1	56.8	18	5113	71.0	12.9	40.9	7	3050
		-15	121.2	10.1	56.5	19	5208	73.2	12.9	40.7	7	3145
	D	- 5	142.0	9.3	64.4	15	6101	86.7	11.7	46.1	6	3725
		-15	144.6	9.4	64.2	15	6212	89.3	11.7	46.0	6	3837
Legend:		Type = Type of coil	t _S = Supply air temperature									
		t _F = Fresh air temperature	Δp _W = Water pressure drop									
		Q = Heat output	m _W = Water quantity									
		H _{max} = Maximum mounting height										
Reference:		<ul style="list-style-type: none"> ■ Room air 18 °C, extract air 20 °C / 20 % rel. humidity ■ Fresh air ratio 10 % 										

Table F7: TopVent® MC heat output

3.7 Cooling capacity

Cooling medium temperature				6/12 °C						8/14 °C					
Size	Type	t _F	RH _F	Q _{sen}	Q _{tot}	t _S	Δp _W	m _W	m _C	Q _{sen}	Q _{tot}	t _S	Δp _W	m _W	m _C
		°C	%	kW	kW	°C	kPa	l/h	kg/h	kW	kW	°C	kPa	l/h	kg/h
MC-6	C	28	40	21.0	21.0	14.0	16	3000	0.0	18.5	18.5	15.2	13	2649	0.0
			60	20.7	20.7	14.2	16	2961	0.0	18.2	18.2	15.4	12	2609	0.0
		32	40	25.7	32.3	15.7	39	4630	9.7	23.3	26.1	16.9	25	3734	4.1
			60	25.4	34.1	15.8	43	4884	12.7	23.0	27.8	17.0	29	3988	7.1
MC-9	C	28	40	32.2	32.2	13.8	16	4614	0.0	28.4	28.4	15.0	12	4064	0.0
			60	31.8	31.8	13.9	16	4554	0.0	28.0	28.0	15.2	12	4004	0.0
		32	40	39.7	51.9	15.3	41	7432	18.0	35.8	35.8	16.6	20	5131	0.0
			60	39.3	54.7	15.4	46	7829	22.7	35.4	38.1	16.7	22	5459	4.0
	D	28	40	38.1	38.1	11.8	13	5451	0.0	33.2	33.2	13.4	10	4756	0.0
			60	37.7	37.8	12.0	13	5409	0.1	32.9	32.9	13.6	10	4706	0.0
		32	40	47.4	64.8	12.7	39	9285	25.6	42.6	53.3	14.3	26	7626	15.7
			60	47.1	68.3	12.9	43	9785	31.2	42.2	56.7	14.5	30	8126	21.3
Legend:		Type = Type of coil	t _S = Supply air temperature												
		t _F = Fresh air temperature	Δp _W = Water pressure drop												
		RH _F = Relative humidity of the fresh air	m _W = Water quantity												
		Q _{sen} = Sensible cooling capacity	m _C = Condensate quantity												
		Q _{tot} = Total cooling capacity													
Reference:		<ul style="list-style-type: none"> ■ At fresh air temperature 28°C: room air 22°C / 50% RH, extract air 24°C ■ At fresh air temperature 32°C: room air 26°C / 50% RH, extract air 28°C Fresh air ratio 10% 													

Table F8: TopVent® MC cooling capacity

3.8 Product information according to ErP

Model	TopVent® MC			Unit
	6-C	9-C	9-D	
Cooling capacity (sensible) ($P_{rated,c}$)	26.5	41.0	48.6	kW
Cooling capacity (latent) ($P_{rated,c}$)	5.6	7.3	15.2	kW
Heating capacity ($P_{rated,h}$)	29.8	46.2	54.2	kW
Total electric power input (P_{elec})	0.85	1.44	1.56	kW
Sound power level (L_{WA})	74	81	81	dB

Table F9: Product information according to Commission Regulation (EU) 2016/2281, Table 13

3.9 Dimensions and weights

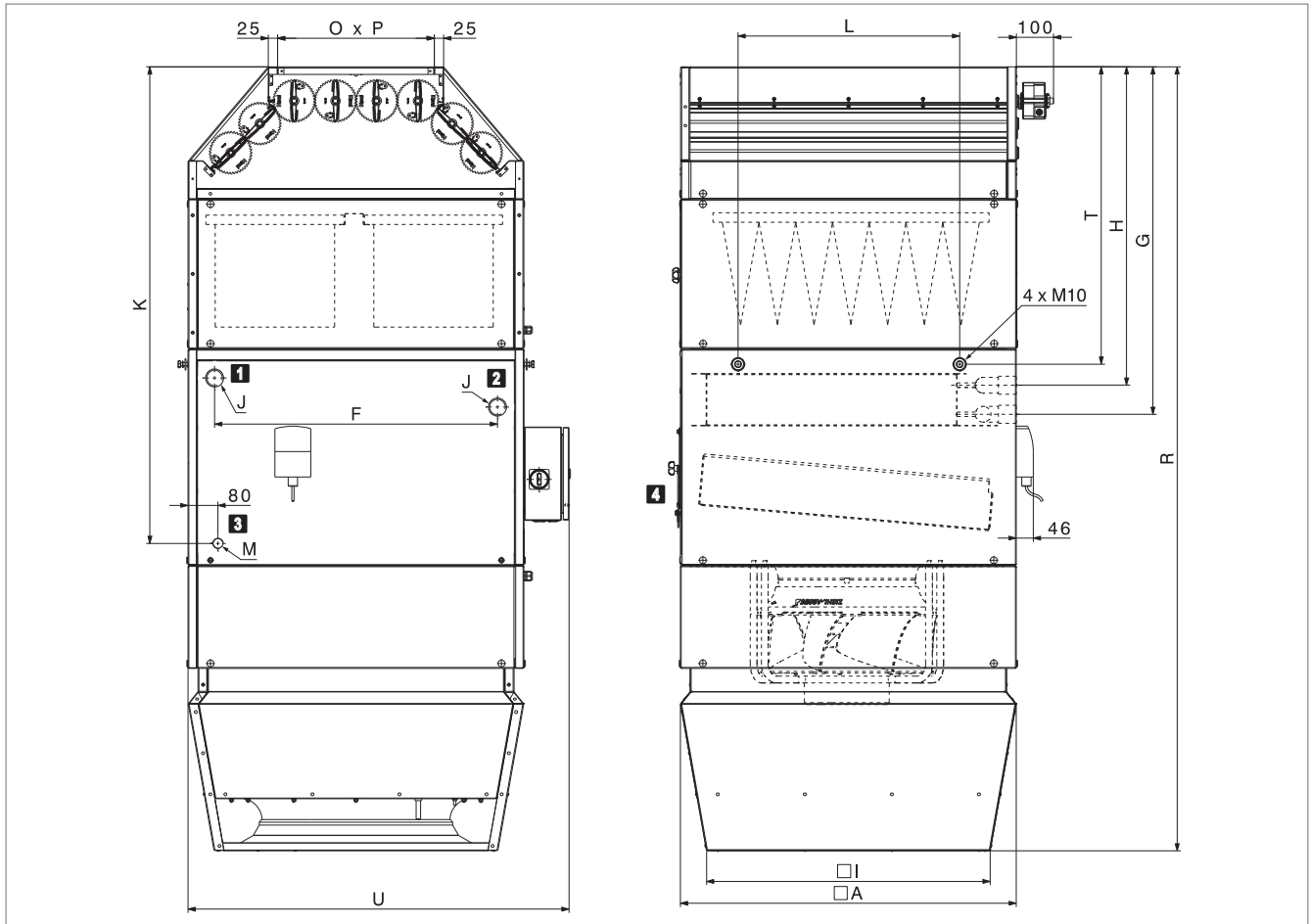

- 1** Return heating/cooling
- 2** Flow heating/cooling
- 3** Condensate connection
- 4** Access panel

Fig. F4: TopVent® MC dimensional drawing

Unit size			MC-6	MC-9	MC-9
Coil type			C	C	D
A	mm		900	1100	1100
F	mm		758	882	882
G	mm		910	931	940
H	mm		832	853	845
I	mm		760	935	935
K	mm		1276	1318	1318
L	mm		594	846	846
$O \times P$	mm		420 × 850	500 × 1050	500 × 1050
R	mm		2100	2190	2190
T	mm		795	900	900
U	mm		1020	1220	1220
J	"		Rp 1¼ (internal)	Rp 1½ (internal)	Rp 2 (internal)
M	"		G 1 (external)	G 1 (external)	G 1 (external)
Water content of heating/cooling coil		l	7.9	12.4	19.2
Weight		kg	266	323	334

Table F10: TopVent® MC dimensions and weights

4 Specification texts

4.1 TopVent® MC

Supply air unit for heating and cooling rooms up to 25 m in height with central heat and cold supply (2-pipe system); equipped with highly efficient air distributor; maximum floor area reached per unit 537 m² (size 6) and 946 m² respectively (size 9).

The unit consists of the following components:

- Fan unit
- Heating/cooling section
- Air-Injector
- Filter box
- Mixed air box
- Unit control box
- Optional components

TopVent® MC units comply with all the requirements of the Ecodesign Directive 2009/125/EC relating to environmentally friendly design of energy-related products. They are systems of the 'fan coil unit' type, provided for in Commission Regulation (EU) 2016/2281.

Fan unit

Consisting of radial fan with high-efficiency EC motor, backwards-curved, three-dimensional contoured blades and free-running rotor made of a high-performance composite material, aerodynamically optimised inflow nozzle, low-noise, with integrated overload protection (integrated in the heating/cooling section).

Heating/cooling section

Housing made of aluzinc sheet, air-tight, flame retardant, hygienic and easy to maintain because of ageing-resistant, silicone-free sealing materials, internally insulated with close-pored polyurethane.

The heating/cooling section contains:

- The highly efficient heating/cooling coil consisting of seamless copper pipes with pressed-on, optimised and profiled aluminium fins and manifolds made of copper; for connection to the hot water and cold water supply
- The pull-out condensate separator with collecting channel, made of high-quality corrosion-resistant material, with a downslope in all directions for rapid draining
- The condensate trap for connecting to a condensate drain (supplied).

Air-Injector

Housing made of aluzinc sheet, air-tight, flame retardant, hygienic and easy to maintain because of ageing-resistant, silicone-free sealing materials, internally insulated with close-pored polyurethane, with:

- Vortex air distributor with concentric outlet nozzle, adjustable vanes and integrated absorber hood
- Actuator for infinitely variable adjustment of the air distribution from vertical to horizontal
 - for draught-free air distribution in the hall under changing operating conditions
 - for the rapid and large-area reduction of temperature stratification in the room through induction of secondary air and strong mixing of the room air with supply air
- Supply air temperature sensor

Filter box

Housing made of aluzinc sheet, internally insulated with EPDM, with 2 ISO coarse 60% bag filters (G4), with differential pressure switch for filter monitoring, factory-wired to the circuit board in the unit control box.

Mixed air box

Housing made of aluzinc sheet, internally insulated with EPDM, with fresh air damper and recirculation damper linked to move in opposite directions; includes actuator with spring return, factory-wired to the circuit board in the unit control box.

Unit control box

Control box fitted at the side of the unit for connection of the power supply and housing the control components that facilitate energy-optimised operation, controlled by the control system TopTronic® C. Housing made of coated sheet steel (light grey RAL 7035), protection rating IP 54. The following components are installed:

- Isolation switch
- Circuit board with all required electrical components, unit controller (clipped on) as well as connection terminals for the following external connections:
 - Heating/cooling valve
 - Heating/cooling pump
 - Return temperature sensor
 - Condensate pump
 - Forced off

The circuit board is fitted with push-in terminals facilitating easy installation of the connection cables. All components in the unit control box as well as sensors and actuators in the unit are fully factory-wired.

Power supply and bus connection to be installed on site.

Options for the unit

Suspension set:

for ceiling installation of the unit consisting of 4 pairs U-profiles made of aluzinc sheet steel, height-adjustable to 1300 mm.

Standard paint finish:

Exterior painting in Hoval red (RAL 3000), including optional components and suspension set

Paint finish as desired:

Exterior painting of the unit in choice of RAL colour, including optional components and suspension set.

Hydraulic assembly diverting system:

Prefabricated assembly for hydraulic diverting system, consisting of mixing valve, regulating valve, ball valve, automatic air vent and screw connections for connection to the unit and to the distributor circuit; mixing valve with plug-in connection, sized for the coil in the unit and the Hoval TopTronic® C control system.

Mixing valve:

Mixing valve with modulating rotary actuator and plug-in connection, sized for the coil in the unit.

Condensate pump:

Consisting of a centrifugal pump and a drip tray, max. delivery rate of 150 l/h with a delivery head of 3 m. Condensate pump with connection cable enclosed.

Pump control for mixing or injection system:

Electrical components for controlling a mixing or injection circuit in the load circuit, factory-installed in the unit control box.

Return temperature sensor:

Temperature sensor for monitoring the heating medium.

4.2 TopTronic® C – System control

Zone-based control system for the energy-optimised operation of decentralised Hoval indoor climate systems. Maximum system size per system bus: 64 control zones with up to 10 supply and extract air handling units or supply air handling units and 10 recirculation air handling units each.

Zone allocation

Configured in advance for the customer at the factory:

	Room designation	Unit type
Zone 1:	_____	_____
Zone 2:	_____	_____
...		

System structure:

- Zone control panel made of coated sheet steel (light grey RAL 7035), ... x ... x ... mm, with:
 - System operator terminal
 - Fresh air temperature sensor
 - 1 zone controller and 1 room temperature sensor per zone (expandable to up to 4 room temperature sensors per zone)
 - Safety relay
 - Electrical cabinet internally pre-wired, all components routed to terminals
- Zone bus: as serial bus for communication with all controllers in one control zone, with robust bus protocol via shielded, twisted bus cable (provided by the client)
- Unit controller: installed in the particular indoor climate unit, works autonomously according to the specifications of the zone controller
- Heating/cooling demand per zone with feedback monitoring

Functions, standard

- Zone-based autonomous room control. Temperature and ventilation control separately adjustable for each zone
- Room temperature control via room-supply air cascade by means of energy-optimised double sequence control with priority circuit for energy recovery (supply and extract air handling units)
- Intelligent automatic heating to reach the desired room temperature at the switching time
- 5 adjustable room temperature set values per zone:
 - Cooling protection (lower setpoint in standby)
 - Overheating protection (upper setpoint in standby)
 - Room set value winter
 - Room set value summer
 - Night cooling set value (free cooling) (supply and extract air handling units)
- Destratification mode for even temperature distribution

- Main operating modes of supply and extract air handling units:
 - VE Ventilation, infinitely variably adjustment
 - AQ.... Air quality, automatic control with Hoval combination sensor (option), optional reference variable:
 - CO₂ or VOC
 - Air humidity (optimised dehumidification mode)
 - REC . Recirculation, infinitely variably adjustment
 - DES.. Destratification
 - EA Exhaust air, infinitely variably adjustment
 - SA Supply air, infinitely variably adjustment
 - ST Standby
- Main operating modes of supply air units:
 - REC . Recirculation, infinitely variably adjustment
 - DES.. Destratification
 - SA Supply air, infinitely variably adjustment
 - ST Standby
- Main operating modes of recirculated air units:
 - REC . Recirculation, infinitely variably adjustment
 - DES.. Destratification
 - ST Standby
- Forced heating (construction site heating) can be activated on each device before completion of the overall system (activation by Hoval service technician)
- Control of draught-free air distribution with the Hoval Air-Injector: the discharge direction is adjusted infinitely variably and automatically according to the respective operating condition and the existing temperatures (heating/cooling).

Operation

- TopTronic® C-ST system operator terminal: touch panel for visualisation and control of all Hoval indoor climate units registered on the bus

Options for operation

- Hoval C-SSR operating software, for visualisation on customer's PC
- TopTronic® C-ZT as zone operator terminal: for simple on-site operation of a control zone
- Manual operating selector switches
- Manual operating selector buttons
- Operating of the units via building management system via standardised interfaces:
 - BACnet
 - Modbus IP
 - Modbus RTU

Alarms, protection

- Central alarm management with registration of all alarms (timestamp, priority, status) in an alarm list and alarm memory of the last 50 alarms; forwarding via e-mail can be set in the parameters.
- If there is a failure of communication, bus stations, sensor systems or supply media, each part of the system transitions to a protection mode which safeguards operation.
- A maintenance mode implemented in the control algorithm for testing all physical data points and alarms guarantees high reliability.
- Pre-programmed data points retrievable via logger function for 1 year

Options for the zone control panel

- Alarm lamp
- Socket

Per zone

- The change-over between heating and cooling can be either automatic or manual
 - Cooling lock switch for automatic changeover
 - Heating/cooling switch for manual changeover
- Additional room air temperature sensors (max. 3)
- Combination sensor room air quality, temperature and humidity
- Combination sensor fresh air temperature and humidity
- Transfer of actual values and setpoints from external systems (0...10 V; 4 - 20 mA)
- Load shedding input
- Operating selector switches on terminal
- Operating selector buttons on terminal
- Control of distributor pump, incl. power supply

Power distribution:

- Circuit breakers and output terminals for Hoval indoor climate units
- Safety relay (4-pin)

4.3 TopTronic® C – System control for TopVent® C-SYS

Control system for the energy-optimised operation of decentralised Hoval indoor climate systems. Maximum system size per system bus: 1 control zone with up to 6 supply air handling units and 10 recirculation air handling units.

System structure

- Zone control panel, designed as compact cabinet for wall installation, made of coated sheet steel (light grey RAL 7035), 380 × 300 × 210 mm, with:
 - Operating panel
 - Zone controller
 - Fresh air temperature sensor
 - 1 Room temperature sensor (expandable to up to 4 room temperature sensors)
 - Safety relay
 - Electrical cabinet internally pre-wired
- Zone bus: as serial bus for communication with all controllers in the control zone, with robust bus protocol via shielded, twisted bus cable (provided by the client)
- Unit controller: installed in the particular indoor climate unit, works autonomously according to the specifications of the zone controller
- Circuit board with external connections for:
 - Collective alarm
 - Forced off
 - Heating demand
 - Setpoint heating demand
 - Fault heat supply
 - Cooling demand
 - Fault cold supply
 - External enabling heating/cooling (for automatic changeover)
 - External setting heating/cooling (for manual changeover)
 - Changeover valves heating/cooling
 - Additional room air temperature sensors (max. 3)
 - External setpoint fresh air ratio
 - Operating selector switch on terminal (digital)
 - Operating selector button on terminal

Functions, standard

- Room temperature control via sequential control of the coils
- Intelligent automatic heating to reach the desired room temperature at the switching time
- 4 adjustable room temperature set values per zone:
 - Cooling protection (lower setpoint in standby)
 - Overheating protection (upper setpoint in standby)
 - Room set value winter
 - Room set value summer
- Destratification mode for even temperature distribution

- Main operating modes of supply air units:
 - REC . Recirculation, infinitely variably adjustment
 - DES.. Destratification
 - SA Supply air, infinitely variably adjustment
 - ST Standby
- Main operating modes of recirculated air units:
 - REC . Recirculation, infinitely variably adjustment
 - DES.. Destratification
 - ST Standby
- Forced heating (construction site heating) can be activated on each device before completion of the overall system (activation by Hoval service technician)
- Control of draught-free air distribution with the Hoval Air-Injector: the discharge direction is adjusted infinitely variably and automatically according to the respective operating condition and the existing temperatures (heating/cooling).

Operation

- Operating panel with LCD display, installed in the door of the zone control panel for visualisation and control of all Hoval indoor climate units registered on the bus

Options for operation

- Hoval C-SSR operating software, for visualisation on customer's PC
- Operating of the units via building management system via standardised interfaces:
 - BACnet
 - Modbus IP
 - Modbus RTU

Alarms, protection

- Central alarm management with registration of all alarms (timestamp, priority, status) in an alarm list and alarm memory of the last 50 alarms; forwarding via e-mail can be set in the parameters.
- If there is a failure of communication, bus stations, sensor systems or supply media, each part of the system transitions to a protection mode which safeguards operation.
- A maintenance mode implemented in the control algorithm for testing all physical data points and alarms guarantees high reliability.
- Pre-programmed data points retrievable via logger function for 1 year

Options for the zone control panel

- Additional room air temperature sensors (max. 3)



TopVent® MHC

Supply air units for ventilating, heating and cooling spaces up to 25 m in height with central heat and cold supply (4-pipe-system)

1 Use	72
2 Construction and operation	72
3 Technical data	76
4 Specification texts	80

G

1 Use

1.1 Intended use

TopVent® MHC units are supply air units for ventilating, heating and cooling spaces up to 25 m in height with central heat and cold supply. They have the following functions:

- Heating (with connection to a hot water supply)
- Cooling (with connection to a water chiller)
- Fresh air supply
- Mixed air operation
- Recirculation operation
- Air distribution and destratification with adjustable Air-Injector
- Air filtration

TopVent® MHC units comply with all the requirements of the Ecodesign Directive 2009/125/EC relating to environmentally friendly design of energy-related products. It is a system of the 'fan coil unit' type.

The Hoval TopTronic® C integrated control system ensures energy-efficient, demand-based operation of Hoval indoor climate systems.

Intended use also includes compliance with the operating instructions. Any usage over and above this use is considered to be not as intended. The manufacturer can accept no liability for damage resulting from improper use.

1.2 User group

The units are only allowed to be installed, operated and maintained by authorised and instructed personnel who are well acquainted with the units and are informed about possible dangers.

The operating instructions are for operating engineers as well as specialists in building, heating and ventilation technology.

2 Construction and operation

2.1 Construction

The TopVent® MHC unit consists of the following components:

- Fan unit: Diagonal fan with energy-saving EC motor, maintenance-free and infinitely variable
- Heating section: Contains the heating coil for heating the supply air with hot water
- Cooling section: Contains the cooling coil for cooling the supply air with cold water and the condensate separator for the condensate generated
- Air-Injector: The Air-Injector is a patented, infinitely variable vortex air distributor for the draught-free introduction of air into the hall under changing operating conditions.
- Filter box: Contains 2 ISO Coarse 60 % bag filters (G4), easily accessible behind the sliding door
- Mixed air box: Contains fresh air damper and recirculation damper linked to move in opposite directions and actuator with spring return

As part of the TopTronic® C control system, the unit control box is an integral component.

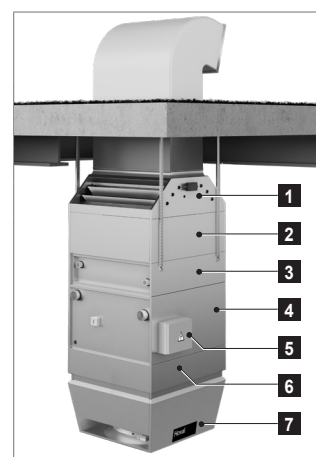

- | | |
|---|------------------|
| 1 | Mixed air box |
| 2 | Filter box |
| 3 | Heating section |
| 4 | Cooling section |
| 5 | Unit control box |
| 6 | Fan unit |
| 7 | Air-Injector |

Fig. G1: TopVent® MHC components

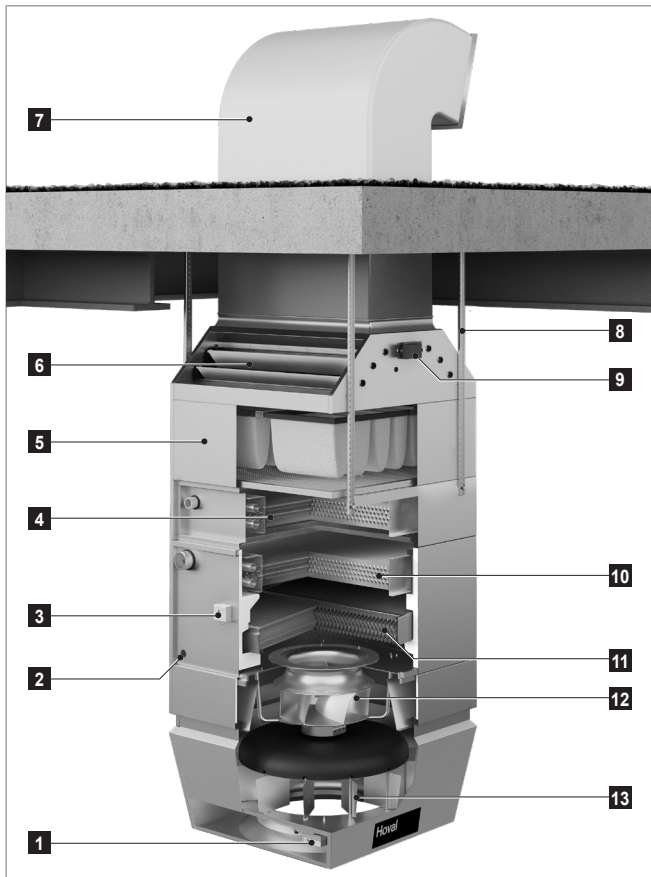

- 1 Actuator Air-Injector
- 2 Condensate connection
- 3 Frost controller
- 4 Heating coil
- 5 Filter box
- 6 Mixed air box
- 7 Fresh air duct (field-supplied)
- 8 Suspension set
- 9 Fresh air damper actuator
- 10 Cooling coil
- 11 Condensate separator
- 12 Fan
- 13 Air-Injector

Fig. G2: TopVent® MHC construction

2.2 Function diagram

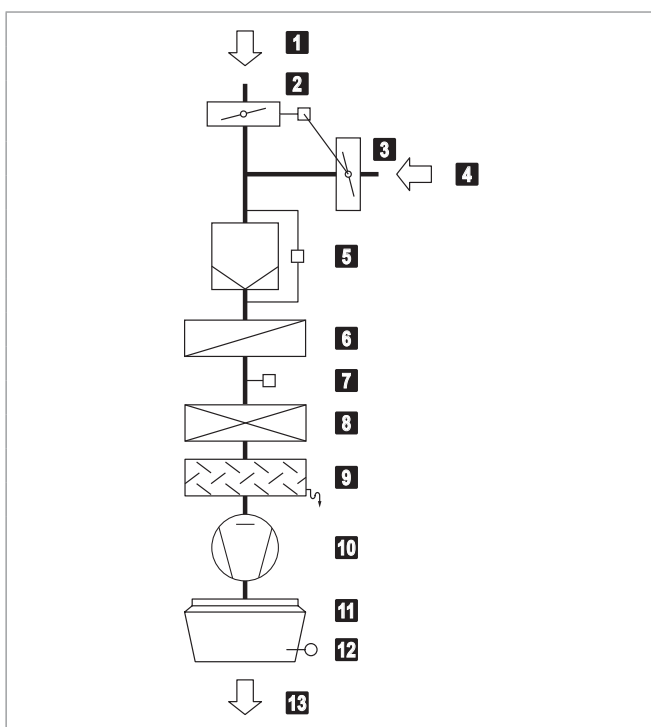

- 1 Fresh air
- 2 Fresh air damper with actuator
- 3 Recirculation damper (opposed to the fresh air damper)
- 4 Extract air
- 5 Air filter with differential pressure switch
- 6 Heating coil
- 7 Frost controller
- 8 Cooling coil
- 9 Condensate separator
- 10 Fan
- 11 Air-Injector with actuator
- 12 Supply air temperature sensor
- 13 Supply air

Fig. G3: TopVent® MHC function diagram

2.3 Operating modes

The TopVent® MHC has the following operating modes:

- Supply air speed 2 ■ Recirculation
- Supply air speed 1 ■ Recirculation speed 1
- Standby

The TopTronic® C control system regulates these operating modes automatically for each control zone in accordance with the specifications in the calendar.

The following points also apply:

- The operating mode of a control zone can be switched over manually.
- Each TopVent® MHC unit can operate individually in a local operating mode:
Off, Supply air speed 2, Supply air speed 1, Recirculation, Recirculation speed 1.

Code	Operating mode	Description
SA2	Supply air speed 2 The unit blows fresh air into the room. The fresh air ratio is adjustable. Heating/cooling is controlled according to the heat/cool demand. The room temperature set value day is active. The unit operates at speed 2 (high air flow rate).	Fan speed 2 Fresh air damper..... 10 % open ¹⁾ Heating/cooling on ²⁾ ¹⁾ Percentage is adjustable ²⁾ Depending on heat or cool demand
SA1	Supply air speed 1 The same as SA2, but the unit operates at speed 1 (low air flow rate)	Fan speed 1 Fresh air damper..... 10 % open ¹⁾ Heating/cooling on ²⁾ ¹⁾ Percentage is adjustable ²⁾ Depending on heat or cool demand
REC	Recirculation On/Off operation: during heat or cool demand, the unit draws in room air, heats or cools it and blows it back into the room. The room temperature set value day is active.	Fan speed 1/2 ¹⁾ Fresh air damper..... closed Heating/cooling on ¹⁾ ¹⁾ Depending on heat or cool demand
DES	■ Destratification: To avoid heat build-up under the ceiling, it may be appropriate to switch on the fan when there is no heat or cool demand (either in permanent operation or in on/off operation depending on the temperature stratification, as desired).	Fan speed 2 Fresh air damper..... closed Heating/cooling off
REC1	Recirculation speed 1 The same as REC, but the unit operates only at speed 1 (low air flow rate)	Fan speed 1 Fresh air damper..... closed Heating/cooling on ¹⁾ ¹⁾ Depending on heat or cool demand
DES	■ Destratification: The same as for REC, but the unit operates only at speed 1	Fan speed 1 Fresh air damper..... closed Heating/cooling off
ST	Standby The unit is ready for operation. The following operating modes are activated if required:	
CPR	■ Cooling protection: If the room temperature drops below the set value for cooling protection, the unit heats up the room in recirculation operation.	Fan speed 2 Fresh air damper..... closed Heating on
OPR	■ Overheating protection: If the room temperature rises above the set value for overheating protection, the unit cools down the room in recirculation operation.	Fan speed 2 Fresh air damper..... closed Cooling..... on

Code	Operating mode	Description
NCS	<ul style="list-style-type: none"> Night cooling: If the room temperature exceeds the set value for night cooling and the current fresh air temperature permits it, the unit blows cool fresh air into the room and extracts warmer room air. 	Fan speed 2 Fresh air damper..... open Heating/cooling off
L_OFF	Off (local operating mode) The unit is switched off. Frost protection for the unit remains active.	Fan off Fresh air damper..... closed Heating/cooling off
-	Forced heating The unit draws in room air, warms it and blows it back into the room. Forced heating can be activated and set as required by the Hoval service technician. For example, it is suitable for heating the hall before taking the control system into operation or if the controller fails during the heating period.	Fan speed 2 ¹⁾ Fresh air damper..... closed ¹⁾ Heating on ¹⁾ 1) Adjustable by the Hoval service technician

Table G1: TopVent® MHC operating modes

3 Technical data

3.1 Type code

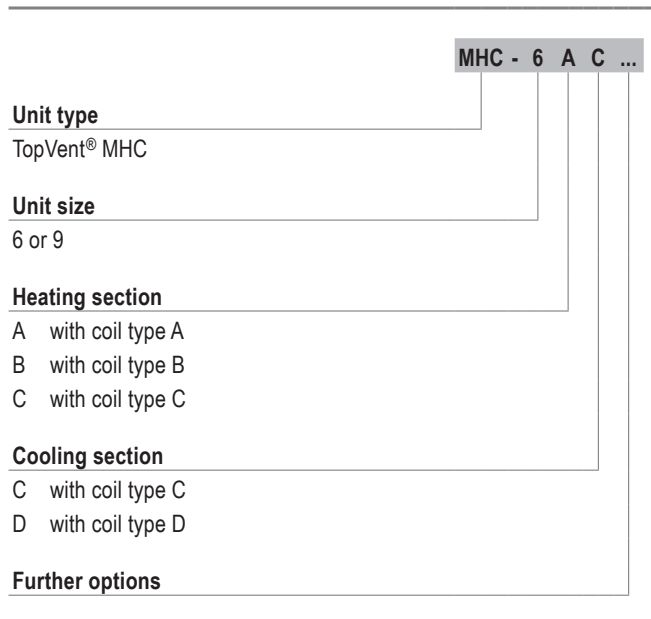

Table G2: TopVent® MHC type code

3.2 Application limits

Extract air temperature	max.	°C	50
Supply air temperature	max.	°C	60
Temperature of the heating medium ¹⁾	max.	°C	90
Pressure of the heating medium	max.	kPa	800
Air flow rate	Size 6:	min.	m ³ /h 3100
	Size 9:	min.	m ³ /h 5000
Condensate quantity	Size 6:	max.	kg/h 90
	Size 9:	max.	kg/h 150

The units cannot be used in:

- Damp locations
- Places with a corrosive or aggressive environment
- Spaces with a large amount of dust
- Areas where there is danger of explosion

¹⁾ Design for higher temperatures on request

Table G3: TopVent® MHC application limits

3.3 Electrical connection

Unit type		MHC-6	MHC-9
Supply voltage	V AC	3 × 400	3 × 400
Permitted voltage tolerance	%	± 5	± 5
Frequency	Hz	50	50
Connected load	kW	3.6	3.6
Current consumption max.	A	5.9	5.9
Series fuse	A	13	13
Protection rating	-	IP 54	IP 54

Table G4: TopVent® MHC electrical connection

3.4 Air flow rate

Unit type		MHC-6	MHC-9
Nominal air flow rate	m ³ /h	6000	9000
Floor area covered	m ²	537	946

Table G5: TopVent® MHC air flow rate

3.5 Sound level

Unit type		MHC-6CC	MHC-9CC
Sound pressure level (at a distance of 5 m) ¹⁾	dB(A)	56	60
Total sound power level	dB(A)	77	82
Octave sound power level	63 Hz	dB 43	47
	125 Hz	dB 61	67
	250 Hz	dB 64	70
	500 Hz	dB 69	74
	1000 Hz	dB 73	78
	2000 Hz	dB 72	76
	4000 Hz	dB 69	74
	8000 Hz	dB 60	67

¹⁾ with a hemispherical radiation pattern in a low-reflection room

Table G6: TopVent® MHC sound level

3.6 Heat output

Heating medium temperature			80/60 °C					60/40 °C				
Size	Type	t _F	Q	H _{max}	t _S	Δp _W	m _W	Q	H _{max}	t _S	Δp _W	m _W
		°C	kW	m	°C	kPa	l/h	kW	m	°C	kPa	l/h
MHC-6	A	- 5	33.1	14.4	33.9	7	1424	19.1	18.8	27.0	2	820
		-15	33.8	14.7	33.2	8	1451	19.7	19.5	26.3	3	848
	B	- 5	47.5	12.1	41.0	13	2040	27.4	15.7	31.1	4	1177
		-15	48.4	12.2	40.5	14	2079	28.3	16.1	30.5	5	1216
	C	- 5	76.8	9.7	55.5	18	3297	45.7	12.3	40.1	7	1965
		-15	78.2	9.7	55.2	19	3358	47.2	12.4	39.9	7	2026
MHC-9	A	- 5	56.1	14.4	36.0	8	2409	32.3	18.8	28.2	3	1387
		-15	57.1	14.6	35.4	8	2455	33.4	19.4	27.5	3	1433
	B	- 5	71.9	12.8	41.2	12	3090	41.3	16.7	31.1	4	1775
		-15	73.3	12.9	40.7	13	3149	42.7	17.0	30.6	4	1834
	C	- 5	119.0	10.1	56.8	18	5113	71.0	12.9	40.9	7	3050
		-15	121.2	10.1	56.5	19	5208	73.2	12.9	40.7	7	3145

Legend: Type = Type of coil t_S = Supply air temperature
t_F = Fresh air temperature Δp_W = Water pressure drop
Q = Heat output m_W = Water quantity
H_{max} = Maximum mounting height

Reference: ■ Room air 18 °C, extract air 20 °C / 20 % rel. humidity
■ Fresh air ratio 10 %

Table G7: TopVent® MHC heat output

3.7 Cooling capacity

Cooling medium temperature				6/12 °C						8/14 °C					
Size	Type	t _F	RH _F	Q _{sen}	Q _{tot}	t _S	Δp _W	m _W	m _C	Q _{sen}	Q _{tot}	t _S	Δp _W	m _W	m _C
		°C	%	kW	kW	°C	kPa	l/h	kg/h	kW	kW	°C	kPa	l/h	kg/h
MHC-6	C	28	40	21.0	21.0	14.0	16	3000	0.0	18.5	18.5	15.2	13	2649	0.0
			60	20.7	20.7	14.2	16	2961	0.0	18.2	18.2	15.4	12	2609	0.0
		32	40	25.7	32.3	15.7	39	4630	9.7	23.3	26.1	16.9	25	3734	4.1
			60	25.4	34.1	15.8	43	4884	12.7	23.0	27.8	17.0	29	3988	7.1
MHC-9	C	28	40	32.2	32.2	13.8	16	4614	0.0	28.4	28.4	15.0	12	4064	0.0
			60	31.8	31.8	13.9	16	4554	0.0	28.0	28.0	15.2	12	4004	0.0
		32	40	39.7	51.9	15.3	41	7432	18.0	35.8	35.8	16.6	20	5131	0.0
			60	39.3	54.7	15.4	46	7829	22.7	35.4	38.1	16.7	22	5459	4.0
	D	28	40	38.1	38.1	11.8	13	5451	0.0	33.2	33.2	13.4	10	4756	0.0
			60	37.7	37.8	12.0	13	5409	0.1	32.9	32.9	13.6	10	4706	0.0
		32	40	47.4	64.8	12.7	39	9285	25.6	42.6	53.3	14.3	26	7626	15.7
			60	47.1	68.3	12.9	43	9785	31.2	42.2	56.7	14.5	30	8126	21.3

Legend: Type = Type of coil t_S = Supply air temperature
t_F = Fresh air temperature Δp_W = Water pressure drop
RH_F = Relative humidity of the fresh air m_W = Water quantity
Q_{sen} = Sensible cooling capacity m_C = Condensate quantity
Q_{tot} = Total cooling capacity

Reference: ■ At fresh air temperature 28°C: room air 22°C / 50% RH, extract air 24°C
■ At fresh air temperature 32°C: room air 26°C / 50% RH, extract air 28°C
Fresh air ratio 10%

Table G8: TopVent® MHC cooling capacity

3.8 Product information according to ErP

Model	TopVent® MHC									Unit
	6-AC	6-BC	6-CC	9-AC	9-BC	9-CC	9-AD	9-BD	9-CD	
Cooling capacity (sensible) ($P_{rated,c}$)	26.5	26.5	26.5	41.0	41.0	41.0	48.6	48.6	48.6	kW
Cooling capacity (latent) ($P_{rated,c}$)	5.6	5.6	5.6	7.3	7.3	7.3	15.2	15.2	15.2	kW
Heating capacity ($P_{rated,h}$)	13.2	18.9	29.8	22.6	28.5	46.2	22.6	28.5	46.2	kW
Total electric power input (P_{elec})	0.92	0.97	1.09	1.59	1.72	1.64	1.77	1.79	1.92	kW
Sound power level (L_{WA})	75	76	77	82	82	82	82	82	83	dB
Contact details	Hoval Aktiengesellschaft Austrasse 70, 9490 Vaduz, Liechtenstein www.hoval.com									

Table G9: Product information according to Commission Regulation (EU) 2016/2281, Table 13

3.9 Dimensions and weights

Unit size		MHC-6			MHC-9			MHC-9		
Coil type		AC	BC	CC	AC	BC	CC	AD	BD	CD
A	mm	900			1100			1100		
F	mm	758			882			882		
G	mm	936			951			951		
H	mm	858			873			873		
I	mm	760			935			935		
K	mm	1550			1622			1622		
L	mm	594			846			846		
O × P	mm	420 × 850			500 × 1050			500 × 1050		
R	mm	2374			2496			2496		
T	mm	1069			1104			1104		
U	mm	1020			1220			1220		
V	mm	1184			1235			1244		
W	mm	1106			1157			1149		
N	"	Rp 1¼ (internal)			Rp 1½ (internal)			Rp 1½ (internal)		
J	"	Rp 1¼ (internal)			Rp 1½ (internal)			Rp 2 (internal)		
M	"	G 1 (external)			G 1 (external)			G 1 (external)		
Water content of heating coil	l	4.6	4.6	7.9	7.4	7.4	12.4	7.4	7.4	12.4
Water content of cooling coil	l	7.9	7.9	7.9	12.4	12.4	12.4	19.2	19.2	19.2
Weight	kg	295	299	305	377	377	388	388	388	399

Table G10: TopVent® MHC dimensions and weights

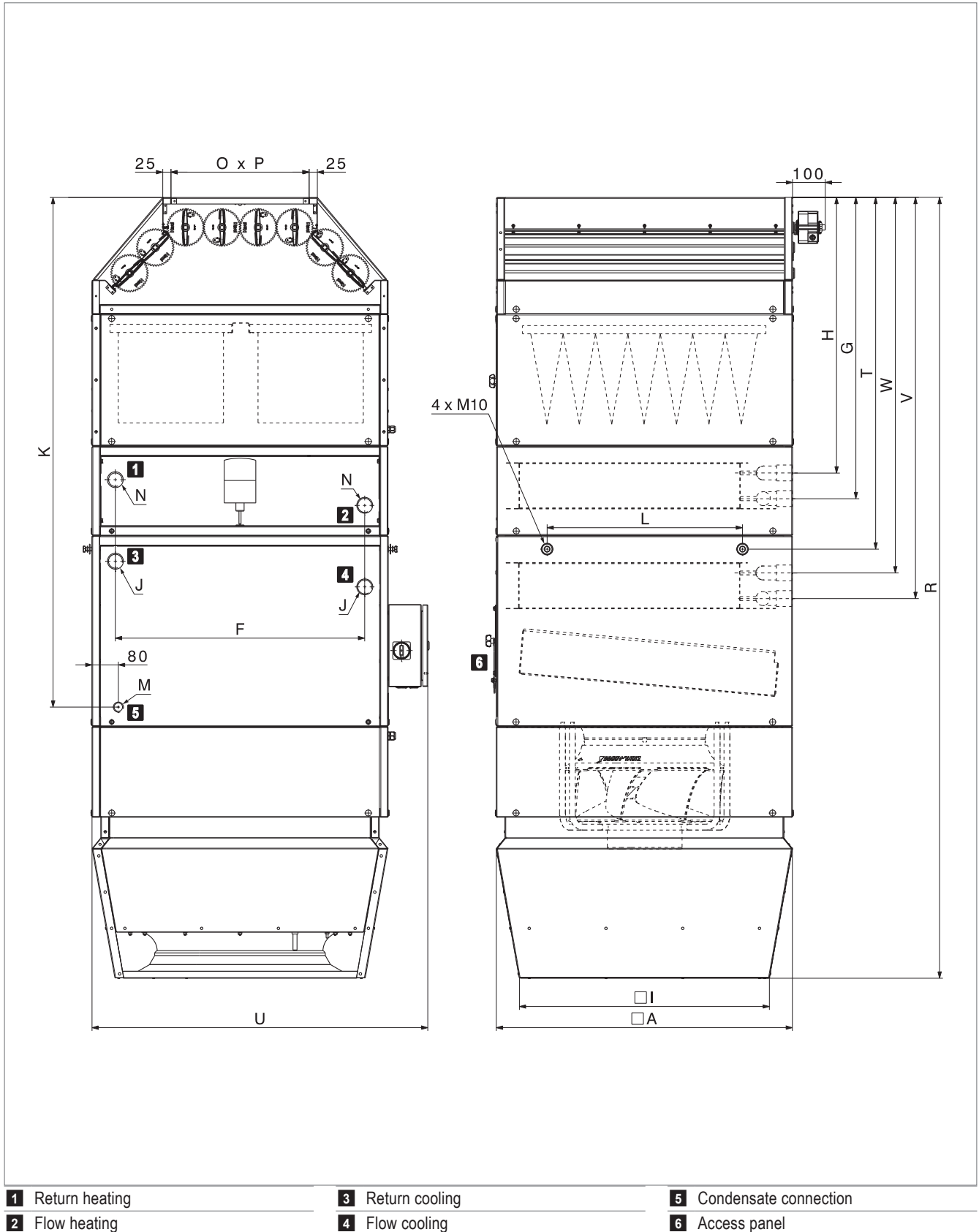

Fig. G4: TopVent® MHC dimensional drawing

4 Specification texts

4.1 TopVent® MHC

Supply air unit for heating and cooling rooms up to 25 m in height with central heat and cold supply (4-pipe system); equipped with highly efficient air distributor; maximum floor area reached per unit 537 m² (size 6) and 946 m² respectively (size 9).

The unit consists of the following components:

- Fan unit
- Heating section
- Cooling section
- Air-Injector
- Filter box
- Mixed air box
- Unit control box
- Optional components

TopVent® MHC units comply with all the requirements of the Ecodesign Directive 2009/125/EC relating to environmentally friendly design of energy-related products. They are systems of the 'fan coil unit' type, provided for in Commission Regulation (EU) 2016/2281.

Fan unit

Consisting of radial fan with high-efficiency EC motor, backwards-curved, three-dimensional contoured blades and free-running rotor made of a high-performance composite material, aerodynamically optimised inflow nozzle, low-noise, with integrated overload protection (integrated in the cooling section).

Heating section

Housing made of aluzinc sheet, air-tight, flame retardant, hygienic and easy to maintain because of ageing-resistant, silicone-free sealing materials, internally insulated with EPDM.

The heating section contains:

- The highly efficient heating coil consisting of seamless copper pipes with pressed-on, optimised and profiled aluminium fins and manifolds made of copper; for connection to the hot water supply

Cooling section

Housing made of aluzinc sheet, air-tight, flame retardant, hygienic and easy to maintain because of ageing-resistant,

silicone-free sealing materials, internally insulated with close-pored polyurethane.

The cooling section contains:

- The highly efficient cooling coil consisting of seamless copper pipes with pressed-on, optimised and profiled aluminium fins and manifolds made of copper; for connection to the cold water supply
- The pull-out condensate separator with collecting channel, made of high-quality corrosion-resistant material, with a downslope in all directions for rapid draining
- The condensate trap for connecting to a condensate drain (supplied).

Air-Injector

Housing made of aluzinc sheet, air-tight, flame retardant, hygienic and easy to maintain because of ageing-resistant, silicone-free sealing materials, internally insulated with close-pored polyurethane, with:

- Vortex air distributor with concentric outlet nozzle, adjustable vanes and integrated absorber hood
- Actuator for infinitely variable adjustment of the air distribution from vertical to horizontal
 - for draught-free air distribution in the hall under changing operating conditions
 - for the rapid and large-area reduction of temperature stratification in the room through induction of secondary air and strong mixing of the room air with supply air
- Supply air temperature sensor

Filter box

Housing made of aluzinc sheet, internally insulated with EPDM, with 2 ISO coarse 60% bag filters (G4), with differential pressure switch for filter monitoring, factory-wired to the circuit board in the unit control box.

Mixed air box

Housing made of aluzinc sheet, internally insulated with EPDM, with fresh air damper and recirculation damper linked to move in opposite directions; includes actuator with spring return, factory-wired to the circuit board in the unit control box.

Unit control box

Control box fitted at the side of the unit for connection of the power supply and housing the control components that facilitate energy-optimised operation, controlled by the control system TopTronic® C. Housing made of coated sheet steel (light grey RAL 7035), protection rating IP 54.

The following components are installed:

- Isolation switch
- Circuit board with all required electrical components, unit controller (clipped on) as well as connection terminals for the following external connections:
 - Heating/cooling valve
 - Heating/cooling pump
 - Return temperature sensor
 - Condensate pump
 - Forced off

The circuit board is fitted with push-in terminals facilitating easy installation of the connection cables. All components in the unit control box as well as sensors and actuators in the unit are fully factory-wired.

Power supply and bus connection to be installed on site.

Options for the unit

Suspension set:

for ceiling installation of the unit consisting of 4 pairs U-profiles made of aluzinc sheet steel, height-adjustable to 1300 mm.

Standard paint finish:

Exterior painting in Hoval red (RAL 3000), including optional components and suspension set

Paint finish as desired:

Exterior painting of the unit in choice of RAL colour, including optional components and suspension set.

Hydraulic assembly diverting system:

Prefabricated assembly for hydraulic diverting system, consisting of mixing valve, regulating valve, ball valve, automatic air vent and screw connections for connection to the unit and to the distributor circuit; mixing valve with plug-in connection, sized for the coil in the unit and the Hoval TopTronic® C control system.

Mixing valve:

Mixing valve with modulating rotary actuator and plug-in connection, sized for the coil in the unit.

Condensate pump:

Consisting of a centrifugal pump and a drip tray, max. delivery rate of 150 l/h with a delivery head of 3 m. Condensate pump with connection cable enclosed.

Pump control for mixing or injection system:

Electrical components for controlling a mixing or injection circuit in the load circuit, factory-installed in the unit control box.

Return temperature sensor:

Temperature sensor for monitoring the heating medium.

4.2 TopTronic® C – System control

Zone-based control system for the energy-optimised operation of decentralised Hoval indoor climate systems. Maximum system size per system bus: 64 control zones with up to 10 supply and extract air handling units or supply air handling units and 10 recirculation air handling units each.

Zone allocation

Configured in advance for the customer at the factory:

	Room designation	Unit type
Zone 1:	_____	_____
Zone 2:	_____	_____
...		

System structure:

- Zone control panel made of coated sheet steel (light grey RAL 7035), ... x ... x ... mm, with:
 - System operator terminal
 - Fresh air temperature sensor
 - 1 zone controller and 1 room temperature sensor per zone (expandable to up to 4 room temperature sensors per zone)
 - Safety relay
 - Electrical cabinet internally pre-wired, all components routed to terminals
- Zone bus: as serial bus for communication with all controllers in one control zone, with robust bus protocol via shielded, twisted bus cable (provided by the client)
- Unit controller: installed in the particular indoor climate unit, works autonomously according to the specifications of the zone controller
- Heating/cooling demand per zone with feedback monitoring

Functions, standard

- Zone-based autonomous room control. Temperature and ventilation control separately adjustable for each zone
- Room temperature control via room-supply air cascade by means of energy-optimised double sequence control with priority circuit for energy recovery (supply and extract air handling units)
- Intelligent automatic heating to reach the desired room temperature at the switching time
- 5 adjustable room temperature set values per zone:
 - Cooling protection (lower setpoint in standby)
 - Overheating protection (upper setpoint in standby)
 - Room set value winter
 - Room set value summer
 - Night cooling set value (free cooling) (supply and extract air handling units)
- Destratification mode for even temperature distribution

- Main operating modes of supply and extract air handling units:
 - VE Ventilation, infinitely variably adjustment
 - AQ.... Air quality, automatic control with Hoval combination sensor (option), optional reference variable:
 - CO₂ or VOC
 - Air humidity (optimised dehumidification mode)
 - REC . Recirculation, infinitely variably adjustment
 - DES.. Destratification
 - EA Exhaust air, infinitely variably adjustment
 - SA Supply air, infinitely variably adjustment
 - ST Standby
- Main operating modes of supply air units:
 - REC . Recirculation, infinitely variably adjustment
 - DES.. Destratification
 - SA Supply air, infinitely variably adjustment
 - ST Standby
- Main operating modes of recirculated air units:
 - REC . Recirculation, infinitely variably adjustment
 - DES.. Destratification
 - ST Standby
- Forced heating (construction site heating) can be activated on each device before completion of the overall system (activation by Hoval service technician)
- Control of draught-free air distribution with the Hoval Air-Injector: the discharge direction is adjusted infinitely variably and automatically according to the respective operating condition and the existing temperatures (heating/cooling).

Operation

- TopTronic® C-ST system operator terminal: touch panel for visualisation and control of all Hoval indoor climate units registered on the bus

Options for operation

- Hoval C-SSR operating software, for visualisation on customer's PC
- TopTronic® C-ZT as zone operator terminal: for simple on-site operation of a control zone
- Manual operating selector switches
- Manual operating selector buttons
- Operating of the units via building management system via standardised interfaces:
 - BACnet
 - Modbus IP
 - Modbus RTU

Alarms, protection

- Central alarm management with registration of all alarms (timestamp, priority, status) in an alarm list and alarm memory of the last 50 alarms; forwarding via e-mail can be set in the parameters.
- If there is a failure of communication, bus stations, sensor systems or supply media, each part of the system transitions to a protection mode which safeguards operation.
- A maintenance mode implemented in the control algorithm for testing all physical data points and alarms guarantees high reliability.
- Pre-programmed data points retrievable via logger function for 1 year

Options for the zone control panel

- Alarm lamp
- Socket

Per zone

- The change-over between heating and cooling can be either automatic or manual
 - Cooling lock switch for automatic changeover
 - Heating/cooling switch for manual changeover
- Additional room air temperature sensors (max. 3)
- Combination sensor room air quality, temperature and humidity
- Combination sensor fresh air temperature and humidity
- Transfer of actual values and setpoints from external systems (0...10 V; 4 - 20 mA)
- Load shedding input
- Operating selector switches on terminal
- Operating selector buttons on terminal
- Control of distributor pump, incl. power supply

Power distribution:

- Circuit breakers and output terminals for Hoval indoor climate units
- Safety relay (4-pin)

4.3 TopTronic® C – System control for TopVent® C-SYS

Control system for the energy-optimised operation of decentralised Hoval indoor climate systems. Maximum system size per system bus: 1 control zone with up to 6 supply air handling units and 10 recirculation air handling units.

System structure

- Zone control panel, designed as compact cabinet for wall installation, made of coated sheet steel (light grey RAL 7035), 380 × 300 × 210 mm, with:
 - Operating panel
 - Zone controller
 - Fresh air temperature sensor
 - 1 Room temperature sensor (expandable to up to 4 room temperature sensors)
 - Safety relay
 - Electrical cabinet internally pre-wired
- Zone bus: as serial bus for communication with all controllers in the control zone, with robust bus protocol via shielded, twisted bus cable (provided by the client)
- Unit controller: installed in the particular indoor climate unit, works autonomously according to the specifications of the zone controller
- Circuit board with external connections for:
 - Collective alarm
 - Forced off
 - Heating demand
 - Setpoint heating demand
 - Fault heat supply
 - Cooling demand
 - Fault cold supply
 - External enabling heating/cooling (for automatic changeover)
 - External setting heating/cooling (for manual changeover)
 - Changeover valves heating/cooling
 - Additional room air temperature sensors (max. 3)
 - External setpoint fresh air ratio
 - Operating selector switch on terminal (digital)
 - Operating selector button on terminal

Functions, standard

- Room temperature control via sequential control of the coils
- Intelligent automatic heating to reach the desired room temperature at the switching time
- 4 adjustable room temperature set values per zone:
 - Cooling protection (lower setpoint in standby)
 - Overheating protection (upper setpoint in standby)
 - Room set value winter
 - Room set value summer
- Destratification mode for even temperature distribution

- Main operating modes of supply air units:
 - REC . Recirculation, infinitely variably adjustment
 - DES.. Destratification
 - SA Supply air, infinitely variably adjustment
 - ST Standby
- Main operating modes of recirculated air units:
 - REC . Recirculation, infinitely variably adjustment
 - DES.. Destratification
 - ST Standby
- Forced heating (construction site heating) can be activated on each device before completion of the overall system (activation by Hoval service technician)
- Control of draught-free air distribution with the Hoval Air-Injector: the discharge direction is adjusted infinitely variably and automatically according to the respective operating condition and the existing temperatures (heating/cooling).

Operation

- Operating panel with LCD display, installed in the door of the zone control panel for visualisation and control of all Hoval indoor climate units registered on the bus

Options for operation

- Hoval C-SSR operating software, for visualisation on customer's PC
- Operating of the units via building management system via standardised interfaces:
 - BACnet
 - Modbus IP
 - Modbus RTU

Alarms, protection

- Central alarm management with registration of all alarms (timestamp, priority, status) in an alarm list and alarm memory of the last 50 alarms; forwarding via e-mail can be set in the parameters.
- If there is a failure of communication, bus stations, sensor systems or supply media, each part of the system transitions to a protection mode which safeguards operation.
- A maintenance mode implemented in the control algorithm for testing all physical data points and alarms guarantees high reliability.
- Pre-programmed data points retrievable via logger function for 1 year

Options for the zone control panel

- Additional room air temperature sensors (max. 3)



Options

1 Type code	86
2 Outlet nozzle	90
3 Suspension set	90
4 Air filtration	90
5 Paint finish	91
6 Recirculation silencer	91
7 Acoustic cowl	91
8 Hydraulic assembly diverting system	92
9 Mixing valve	94
10 Condensate pump	94
11 Return temperature sensor	94
12 Pump control for mixing or injection system	95

1 Type code

1.1 Type code for recirculation units

Availability	THC - 9 B C / ST . D1 / S . FK . LH . UA / Y . KP / TC . - . PP . RF									
	Unit type									
	TH	TC	THC							
				TH	Recirculation unit with heating section					
				TC	Recirculation unit with heating/cooling section					
				THC	Recirculation unit with heating and cooling section					
	Unit size									
	•	•	•	6	Size 6					
	•	•	•	9	Size 9					
	Heating section									
		•		-	without heating section					
	•		•	A	with coil type A					
	•		•	B	with coil type B					
	•		•	C	with coil type C					
	Heating/cooling section									
	•			-	without heating/cooling section					
		•	•	C	with coil type C					
		•	•	D	with coil type D					
	Design									
	•	•	•	ST	Standard					
	Air outlet									
	•	•	•	D1	Design with Air-Injector					
	•			DN	Outlet nozzle					
	Installation									
	•	•	•	-	without					
	•	•	•	S	Suspension set					
	Filter box									
	•	•	•	--	without					
	•	•	•	FK	Filter box					
	•	•	•	FF	Flat filter box					
	Paint finish									
	•	•	•	--	without					
	•	•	•	LH	Standard paint finish					
	•	•	•	LU	Paint finish as desired					

Availability

THC - 9 B C / ST . D1 / S . FK . LH . UA / Y . KP / TC . - . PP . RF

TH TC THC

TH	TC	THC	
			Silencer
•	•	•	-- without
•	•	•	U- Recirculation silencer
•	•	•	-A Acoustic cowl
•	•	•	UA Recirculation silencer and acoustic cowl
			Hydraulics
•	•	•	- without
•	•	•	Y Hydraulic assembly diverting system
•	•	•	M Mixing valve
			Condensate pump
•	•	•	-- without
•	•	•	KP Condensate pump
			Control system
•	•	•	TC TopTronic® C
•	•	•	KK Terminal box design
			Reserve
			Pump control
•	•	•	-- without
•	•	•	PH Heating pump
•	•	•	PK Heating or cooling pump
•	•	•	PP Heating pump and cooling pump
			Return temperature sensor
•	•	•	-- without
•	•	•	RF Return temperature sensor

Table H1: Type codes and availability of recirculation units

1.2 Type code for supply air units

Availability		MHC - 9 B C / ST . D1 / S . -- . LH . A / Y . KP / TC . PP . RF									
Unit type											
MH	Supply air unit with heating section										
MC	Supply air unit with heating/cooling section										
MHC	Supply air unit with heating and cooling section										
Unit size											
•	6	Size 6									
•	9	Size 9									
Heating section											
•	-	without heating section									
•	A	with coil type A									
•	B	with coil type B									
•	C	with coil type C									
Heating/cooling section											
•	-	without heating/cooling section									
•	C	with coil type C									
•	D	with coil type D									
Design											
•	ST	Standard									
Air outlet											
•	D1	Design with Air-Injector									
Installation											
•	-	without									
•	S	Suspension set									
Reserve											
Paint finish											
•	--	without									
•	LH	Standard paint finish									
•	LU	Paint finish as desired									
Silencer											
•	--	without									
•	A	Acoustic cowl									
Hydraulics											
•	-	without									
•	Y	Hydraulic assembly diverting system									
•	M	Mixing valve									

Availability

MHC - 9 B C / ST . D1 / S . -- . LH . A / Y . KP / TC . PP . RF

MH	MC	MHC
•	•	•
•	•	•
•	•	•
•	•	•
•	•	•
•	•	•
•	•	•
•	•	•

Condensate pump

- without
- KP Condensate pump

Control system

- TC TopTronic® C

Pump control

- without
- PH Heating pump
- PK Heating or cooling pump
- PP Heating pump and cooling pump

Return temperature sensor

- without
- RF Return temperature sensor

Table H2: Type code and availability of supply air units

2 Outlet nozzle

For low-cost recirculation heating the TopVent® TH unit is available with a simple outlet nozzle. The air discharge angle cannot be adjusted. Units with outlet nozzle are well suited for applications with lower comfort requirements and for large mounting heights (e.g. in high-bay warehouses).

The outlet nozzle replaces the Air-Injector. The external dimensions of the unit remain the same. The weight is reduced:

- Size 6: – 15 kg
- Size 9: – 21 kg



Fig. H1: TopVent® TH with outlet nozzle

3 Suspension set

A suspension set is available to make it easy to install the units on the ceiling. The set consists of 4 pairs of U-profiles made of aluzinc sheet metal and is height-adjustable up to 1300 mm.

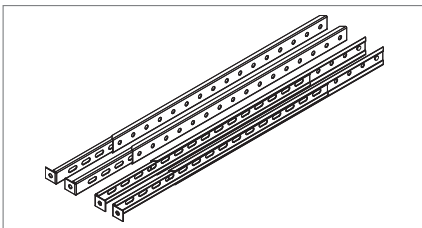

Fig. H2: Suspension set

4 Air filtration

For hygiene reasons, Hoval recommends always fitting TopVent® units with a filter.

4.1 Filter box

A filter box with 2 bag filters can be installed for the purpose of filtering the recirculation air. The modular construction made of aluzinc sheet metal with 2 sliding doors makes it easy to replace the filters.



Notice

In the planning phase make sure there is enough space in front of the sliding doors so that the filters can be replaced with ease.

A pressure difference control device is installed for automatic monitoring of the filter. It shows when the filters have to be changed.

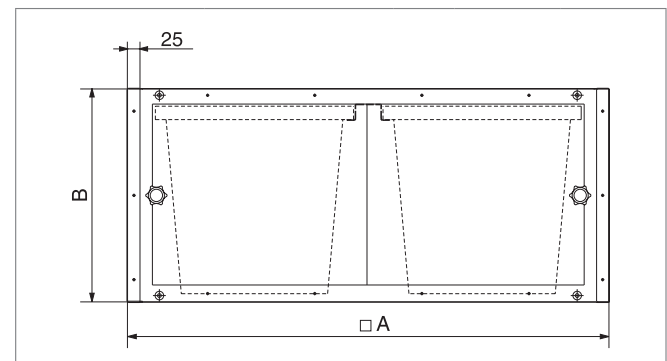

Size			6	9
A		mm	900	1100
B		mm	400	400
Filter class			ISO coarse 60 % (G4)	
Weight		kg	20	24
Factory setting of differential pressure switches	TH, MH	Pa	120	120
	TC, THC, MC, MHC	Pa	180	180

Table H3: Filter box technical data

4.2 Flat filter box

A flat filter box with 4 pleated cell filters can be installed for the purpose of filtering the recirculation air.

A pressure difference control device is installed for automatic monitoring of the filter. It shows when the filters have to be changed.

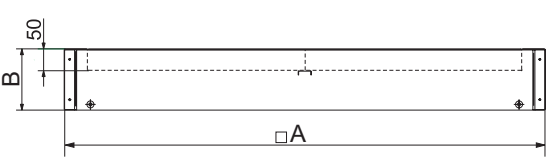

Size			6	9
A		mm	900	1100
B		mm	140	165
Filter class			ISO coarse 60 % (G4)	
Weight		kg	10	12.5
Factory setting of differential pressure switches	TH	Pa	50	50
	TC, THC	Pa	100	100

Table H4: Flat filter box technical data

5 Paint finish

If the customer wishes, the units can be provided with an exterior paint finish. There are 2 possibilities:

- Standard paint finish in Hoval red (RAL 3000)
- Paint finish in desired RAL colour

6 Recirculation silencer

The use of a recirculation silencer for noise reduction is recommended mainly if the TopVent® units are installed under flat, hard ceilings (e.g. made of concrete or sheet steel). The recirculation silencer is mounted on the appliance and thus reduces the sound reflection from the ceiling. Insertion attenuation is 3 dB compared with the total sound power level of each TopVent® unit.

Mount the recirculation units as usual via the 4 fastening points in the heating or heating/cooling section (for example, using the optional suspension set).



Caution

Risk of injury from falling parts. The silencer cannot bear the weight of the appliance. Do not locate any suspension points on the silencer.

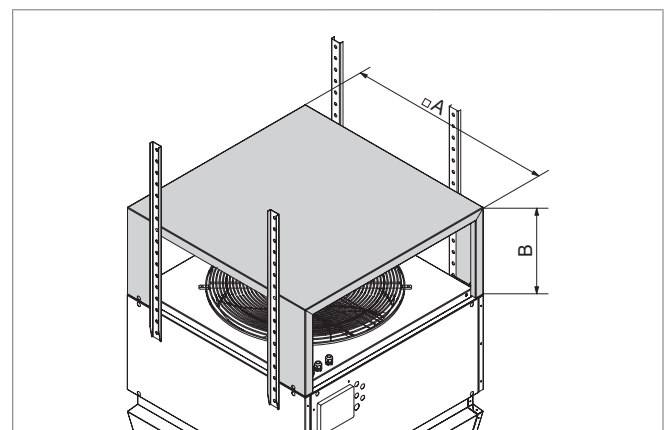

Size			6	9
A		mm	900	1100
B		mm	380	485
Weight		kg	15	20

Table H5: Recirculation silencer dimensions and weights

7 Acoustic cowl

The acoustic cowl reduces the noise level in the room; it is installed in the Air-Injector. This does not change the outside dimensions of the Air-Injector.

Insertion attenuation is 4 dB compared with the total sound power level of each TopVent® unit.

8 Hydraulic assembly diverting system

Assemblies for hydraulic diverting, which are optimally matched to the units, are available for easy installation of TopVent® units. Please note the following:

- Install the assembly horizontally.
- Mount the assembly so that its weight does not need to be absorbed by the coil.
- Insulate the assembly.

Default settings for the hydraulic alignment

Read off the default settings from the diagrams below. The curves 1.0 to 4.0 correspond to the revolutions of the valve spindles of the balancing valve; they are shown on the turning knob:

0.0 __ Valve closed

4.0 __ Valve fully open

The coil and the hydraulic assembly are already included in the specified pressure drops. Thus, only consider the pressure drops of the distributor circuit up to the screw connections.

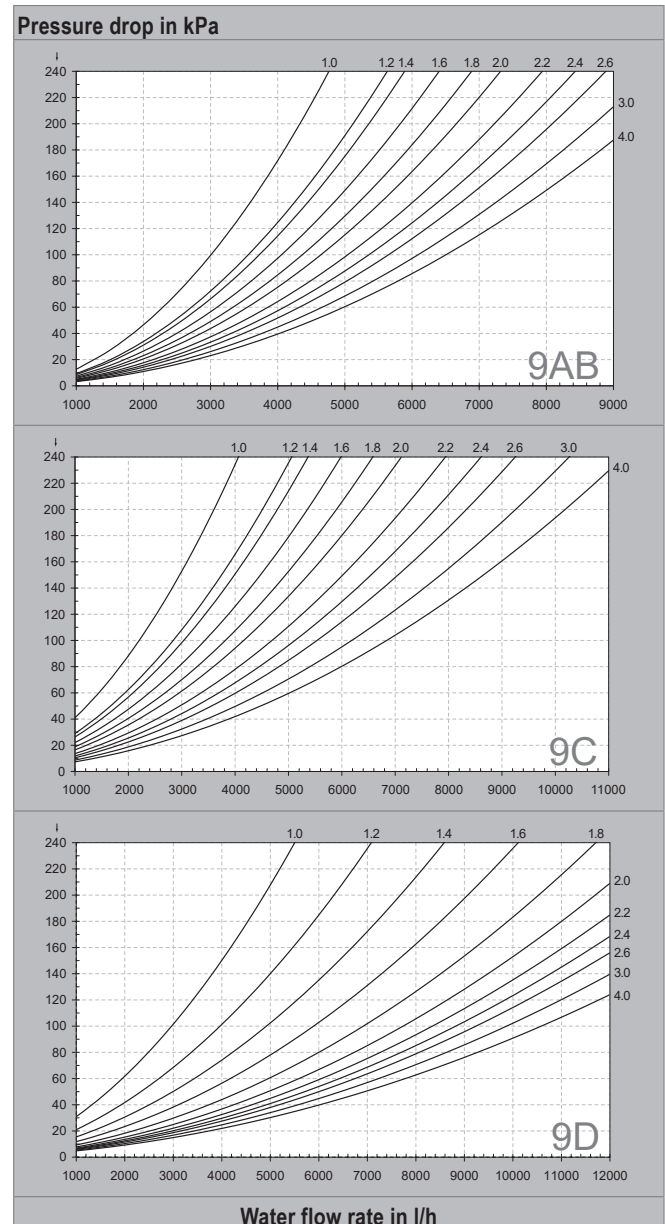
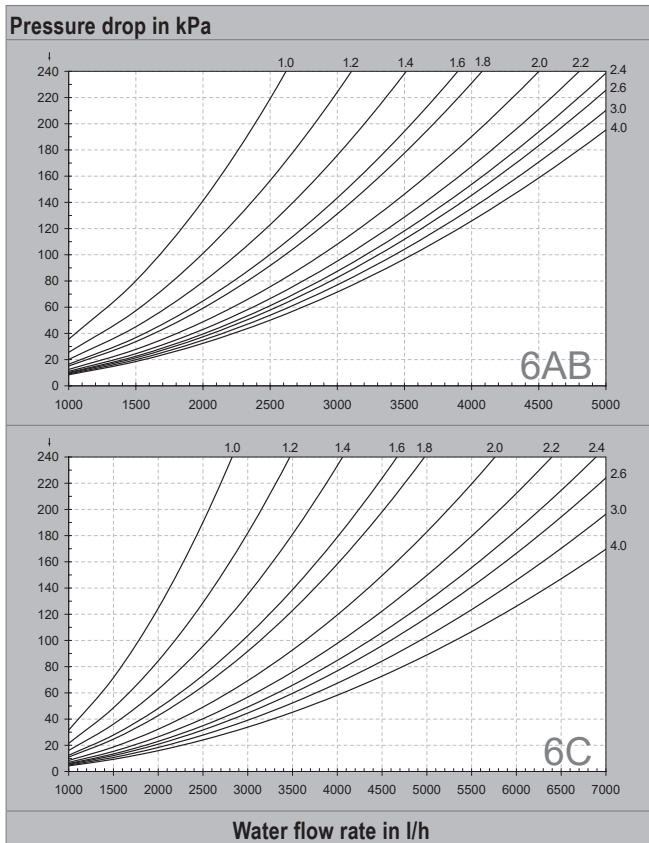
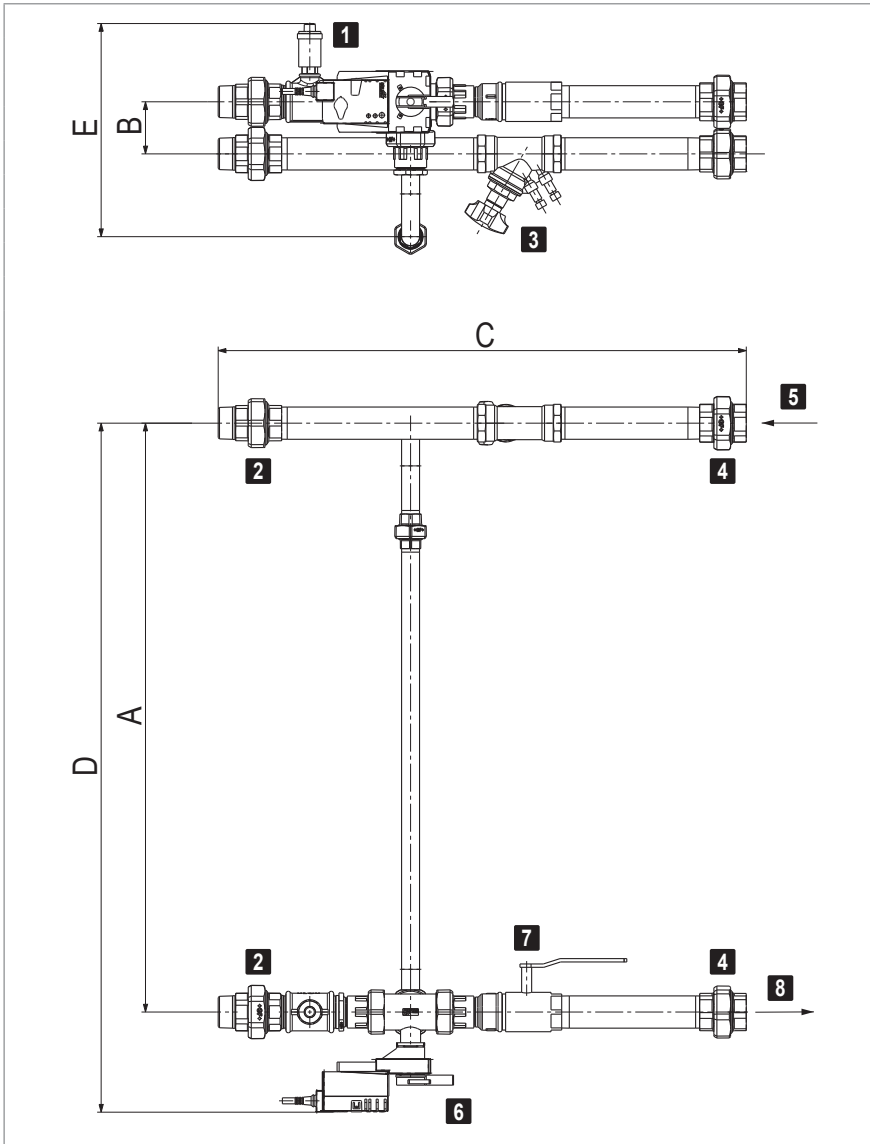

Fig. H3: Default settings for the balancing valves



- 1 Automatic air vent
- 2 Coil screw joint
- 3 Control valve
- 4 Distributor circuit screw joint
- 5 Flow
- 6 Mixing valve
- 7 Ball valve
- 8 Return

Fig. H4: Hydraulic assembly dimensional drawing

Type	A	B	C	D	E	Screw joint	Weight
Y-6AB	758	78	726	904	315	1¼"	11
Y-6C	758	78	745	904	315	1¼"	11
Y-9AB	882	78	770	1028	319	1½"	13
Y-9C	882	78	791	1032	319	1½"	14
Y-9D	882	95	840	1032	326	2"	19

Table H6: Hydraulic assembly dimensions and weights (in mm resp. kg)

Type	Mixing valve	Control valve
Y-6AB	DN20 / kvs 6.3	STAD DN32
Y-6C	DN25 / kvs 10	STAD DN32
Y-9AB	DN25 / kvs 10	STAD DN40
Y-9C	DN32 / kvs 10	STAD DN40
Y-9D	DN40 / kvs 16	STAD DN50

Table H7: Valves of the hydraulic assembly

Electrical data of the mixing valves	
Nominal voltage	24 VAC/DC
Nominal voltage frequency	50/60 Hz
Power consumption for wire sizing	23 VA
Control signal Y	0...10 VDC
Operating range Y	2...10 VDC
Position response U	2...10 VDC
Actuator run time	9 s / 90°

Table H8: Mixing valves electrical data

9 Mixing valve

Mixing valves, which are optimally matched to the units, are available for easy installation of TopVent® units. They have the following specifications:

- 3-way mixing valve with modulating rotary actuator (run time 9 s)
- Flow characteristic:
 - Equal percentage control path
 - Linear bypass
- Integrated position control and response

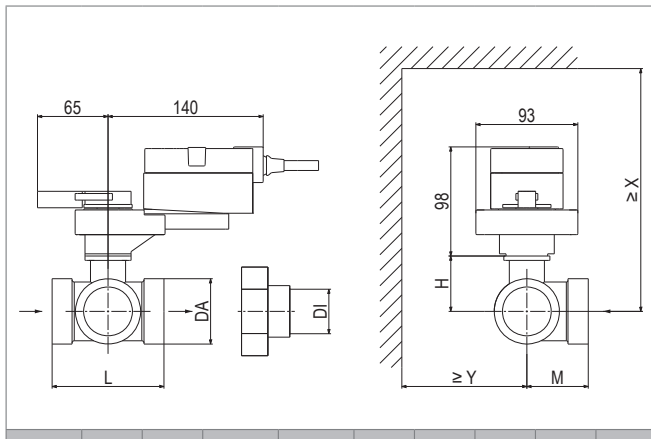

Type	DN	kvs m ³ /h	DA "	DI "	L mm	H mm	M mm	X mm	Y mm
M-6AB	20	6.3	G 1¼	Rp ¾	86	46	42	220	90
M-6C	25	10	G 1½	Rp 1	85	46	45	220	90
M-9AB	25	10	G 1½	Rp 1	85	46	45	220	90
M-9C	32	10	G2	Rp 1¼	104	46	56	220	90
M-9D	40	16	G 2¼	Rp 1½	115	51	56	230	90

Table H9: Mixing valve dimensions

Type	Weight
M-6AB	2.6
M-6C	3.1
M-9AB	3.1
M-9C	4.0
M-9D	4.7

Table H10: Mixing valve weights (in kg)

Mixing valves electrical data	
Nominal voltage	24 VAC/DC
Nominal voltage frequency	50/60 Hz
Power consumption for wire sizing	23 VA
Control signal Y	0...10 VDC
Operating range Y	2...10 VDC
Position response U	2...10 VDC
Actuator run time	9 s / 90°

Table H11: NRQ24A-SR mixing valves electrical data

10 Condensate pump

TopVent® cooling units must be connected to a condensate drainage system. For applications in which connection to the waste water system is too expensive or not possible for structural reasons, a condensate pump can be provided. This is installed directly under the condensate drain connection; the supplied container is prepared for installation on the unit. It pumps the condensate through a flexible hose to a delivery head of 3 m, thus enabling discharge of the condensate

- through waste water pipes directly below the ceiling,
- onto the roof.

Flow rate (at 3 m delivery head)	l/h	max. 150
Tank capacity	l	max. 1.9
Dimensions (L x W x H)	mm	288 x 127 x 178
Weight	kg	2.4

Table H12: Condensate pump technical data

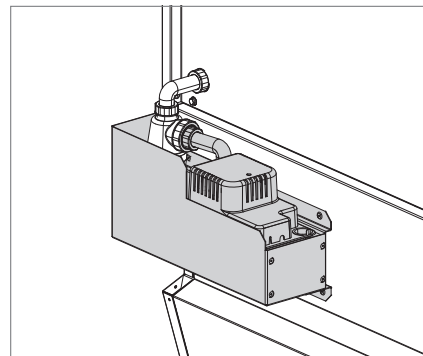

Fig. H5: Condensate pump

11 Return temperature sensor

The return temperature sensor monitors the return temperature of the heating medium.

12 Pump control for mixing or injection system

Instead of the diverting system, a mixing or injection circuit can also be installed in the load circuit.

Please note the following:

- Not only the mixing valves but also the pumps in the load circuit are controlled directly by the control block.
- Terminals for wiring the mixing valves and the pumps in the load circuit are located in the connection box.
- Make sure that valves and pumps which meet the following requirements are provided on site.

Requirements for mixing valves

- Use 3-way mixing valves with the following flow characteristics:
 - Equal percentage control path
 - Linear bypass
- The valve authority must be ≥ 0.5 .
- The maximum run time of the valve actuator is 45 s.
- The valve actuator must be continuous, i.e. the stroke changes in proportion to the control voltage (0...10 VDC or 2...10 VDC).
- The valve actuator must be designed with a position response (0...10 VDC or 2...10 VDC).
- The maximum power consumption is 20 VA.
- Install the valve close to the unit (max. distance 2 m).

Requirements for pumps

- Voltage230 V AC
- Currentup to 4.0 A

Requirements on changeover valves

Use changeover valves conforming to the following specification:

- 3-way changeover valves
- Supply voltage 24 V AC
- 1-wire control (0/24 V AC)
- Position response via limit switches (0°/90°)
- Power consumption max. 44 VA

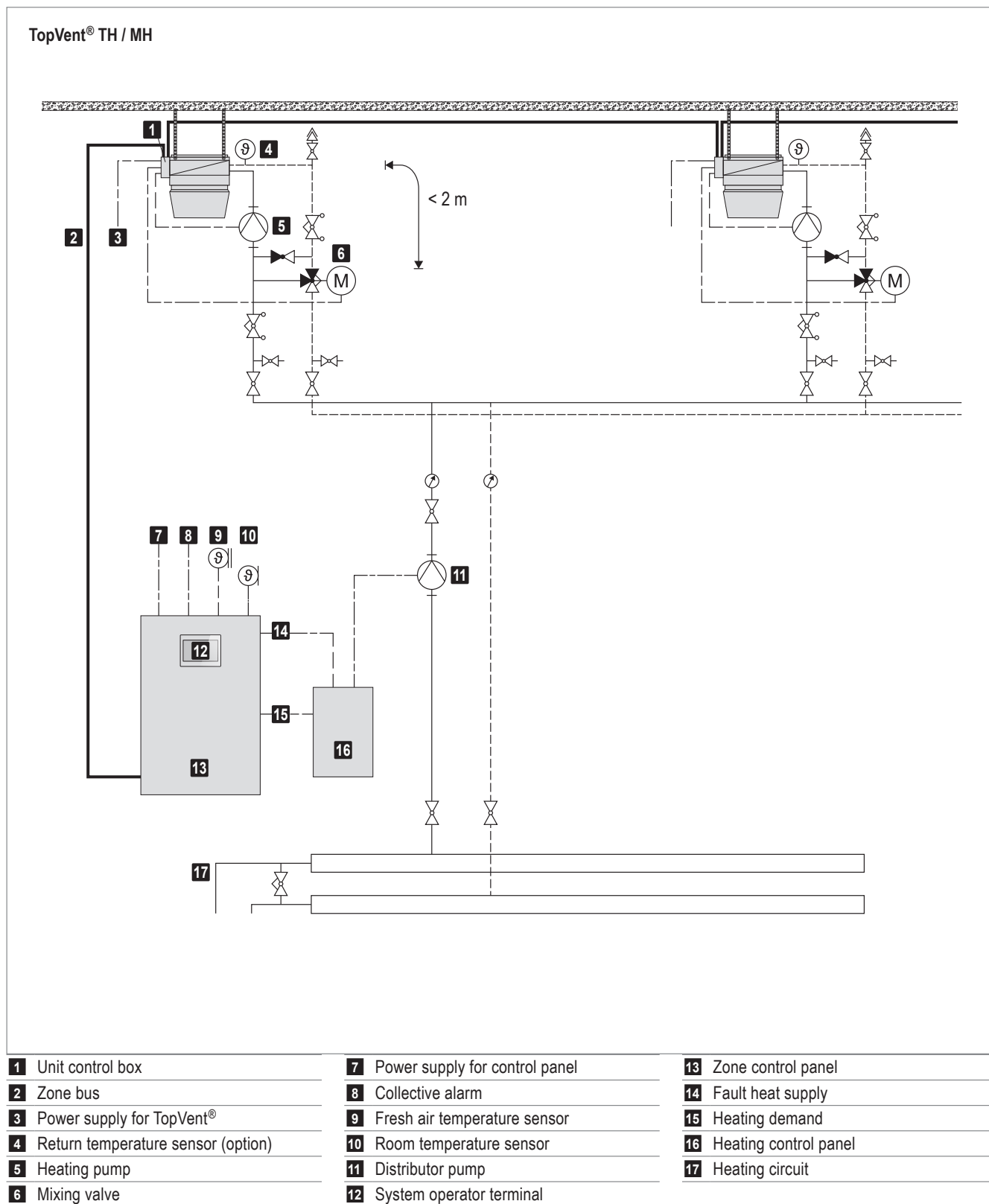

Fig. H6: Schematic diagram for injection system TopVent® TH / MH

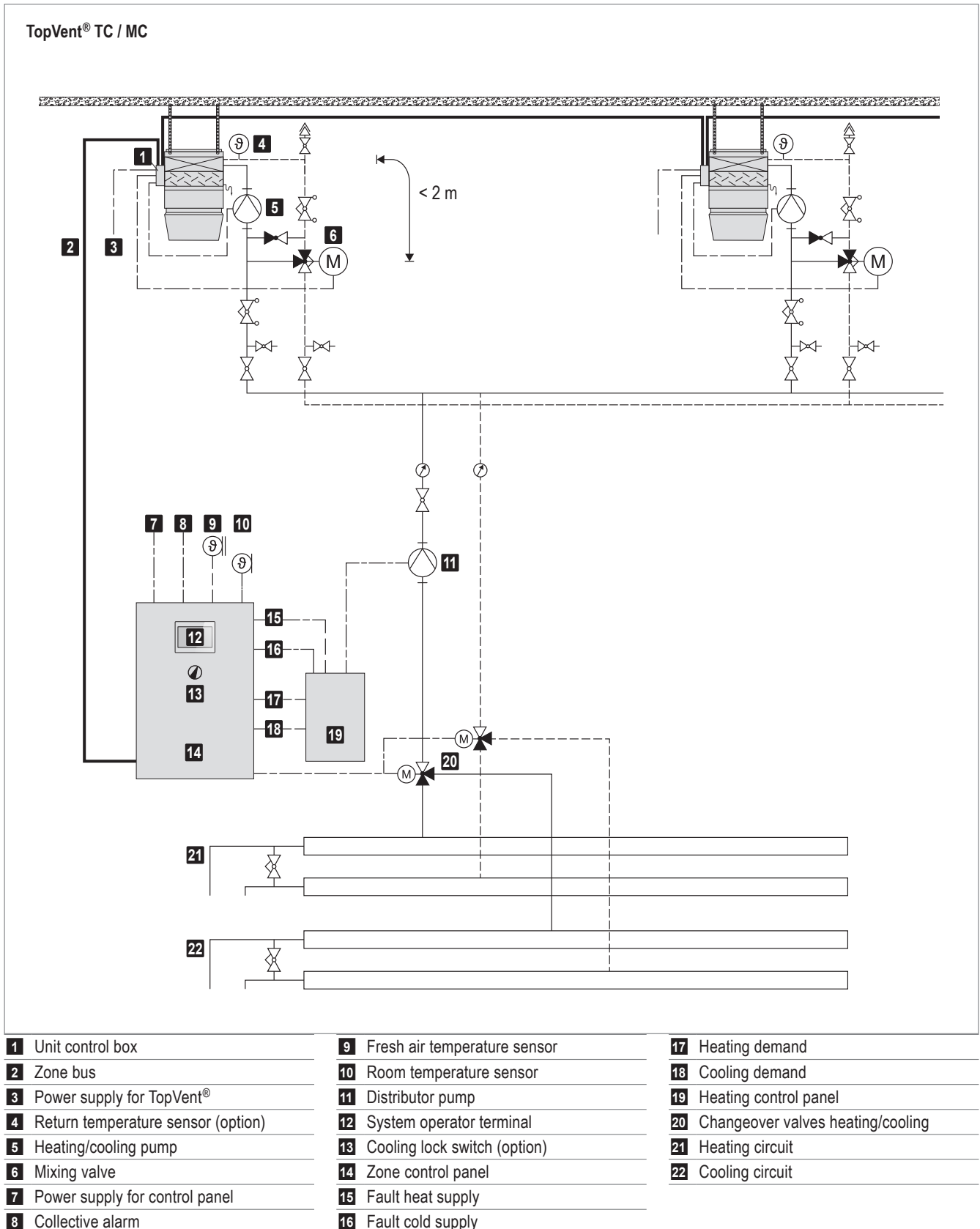
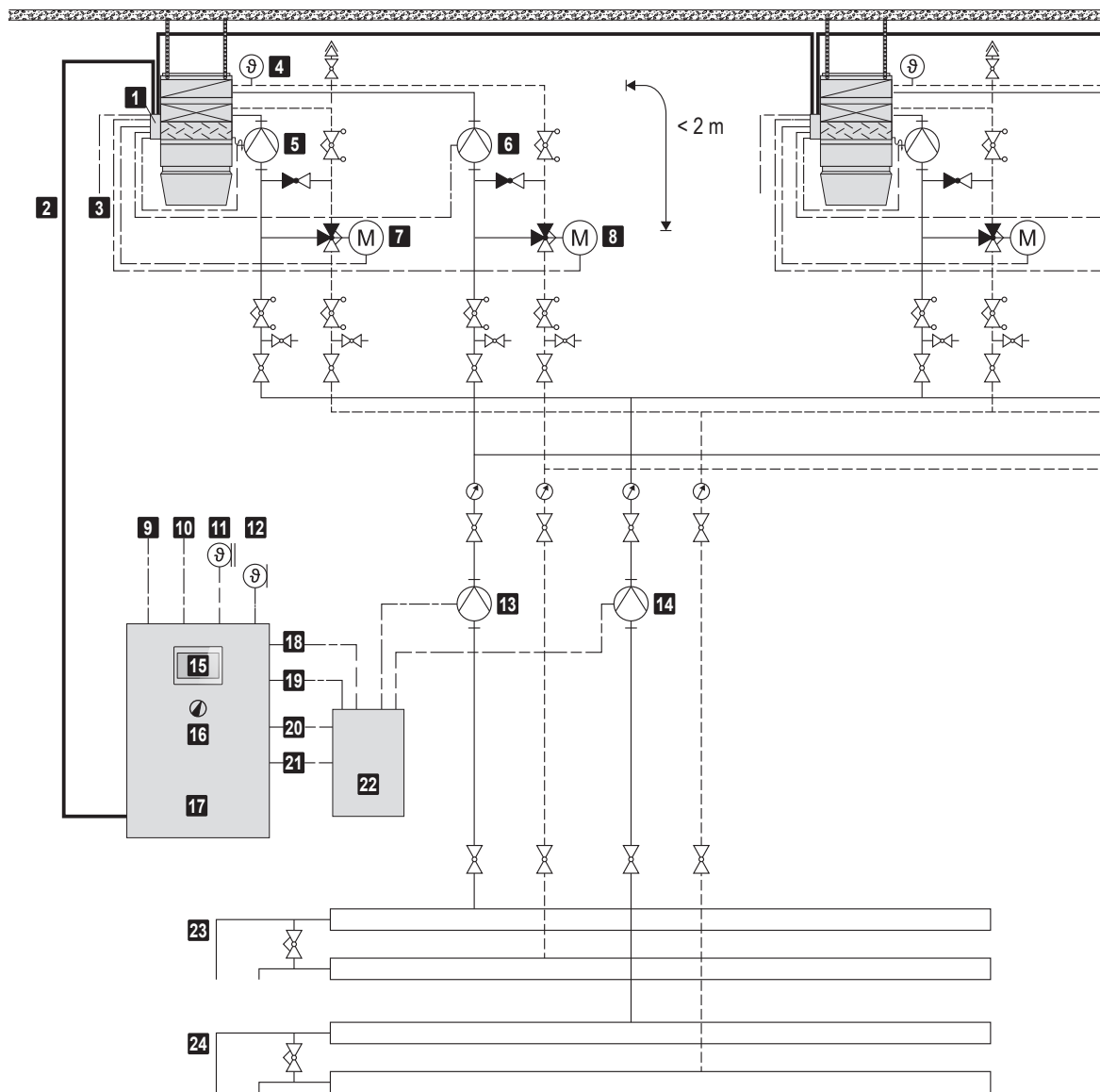

Fig. H7: Schematic diagram for injection system TopVent® TC / MC

TopVent® THC / MHC



- | | | |
|---|---|---------------------------------|
| 1 Unit control box | 9 Power supply for control panel | 17 Zone control panel |
| 2 Zone bus | 10 Collective alarm | 18 Fault heat supply |
| 3 Power supply for TopVent® | 11 Fresh air temperature sensor | 19 Fault cold supply |
| 4 Return temperature sensor (option) | 12 Room temperature sensor | 20 Heating demand |
| 5 Cooling pump | 13 Distributor pump heating | 21 Cooling demand |
| 6 Heating pump | 14 Distributor pump cooling | 22 Heating control panel |
| 7 Mixing valve cooling | 15 System operator terminal | 23 Heating circuit |
| 8 Mixing valve heating | 16 Cooling lock switch (option) | 24 Cooling circuit |

Fig. H8: Schematic diagram for injection system TopVent® THC / MHC



Transport and installation

1 Installation	100
2 Hydraulic installation	101
3 Electrical installation	105

1 Installation

1.1 Preparation

The following guidelines are important when preparing for installation:

- The scope of delivery includes:
 - TopVent® unit, delivered on a pallet
 - Accessories (installation material, trap, temperature sensor)
 - Optional components

TopVent® unit

- Make sure that a lifting platform is available.
- Only secure the unit to ceilings with sufficient load-bearing capacity.
- For the purposes of installation the unit is provided with 4 M10 rivet nuts with hexagon bolts and washers.
 - Fasten the unit to the ceiling by means of the optional suspension set or by means of flat iron bars, perforated bars, angles, steel cables or similar.
 - Do not use eyebolts.

1.2 Positioning

- Comply with the minimum and maximum distances.
- All air inlet and air outlet openings must be freely accessible. The supply air jet must be free to spread out unhindered.
- The access panels in the unit must be freely accessible.
- Clearance of at least 0.9 m is required for maintenance work around the heating/cooling section.

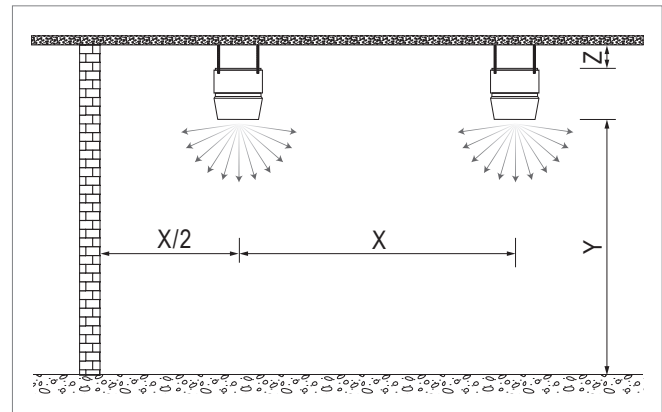

Size			6	9
Unit clearance X	min.	m	12	14
	max.	m	23	31
Distance from ceiling Z	min.	m	0.3	0.4
Mounting height Y	min.	m	4	5
	max. ¹⁾	m	Approx. 9...25	

1) The maximum mounting height varies depending on the boundary conditions (for values, see table of heat outputs or calculation with the 'HK-Select' selection program)

Table I1: Minimum and maximum distances

1.3 Unit installation

Proceed as follows to position the unit:

- Transport the unit to the installation site and rotate it to the correct position.
- Fasten the unit to the designated suspension points.
- Connect supply air units to a fresh air duct via a canvas connection and connect both flanges with an earth wire.

2 Hydraulic installation

2.1 Heating/cooling coil

The TopTronic® C control system is designed for a distributor circuit with separate hydraulic connection of the units; i.e. a mixing valve is installed in front of each unit. The diverting system is used as standard.

Requirements on the boiler system and the distributor circuit

- Hydraulically balance the pipework for the the individual units within a control zone to ensure even distribution.
- The heating medium must be available at the mixing valve without delay in the required amount and temperature.
- The condensate separator in cooling units only functions while the fan is running. No coolant must be allowed to circulate in the coil when the unit is switched off.
- Depending on local conditions, check whether compensators for linear expansion are required for the supply and return lines and/or articulated connections are required for the units.
- Do not fasten any loads to the coil, e.g. by means of the flow or return lines.
- Insulate the hydraulic lines.

The TopTronic® C control system switches on the heating/cooling pumps and the heating/cooling demand every day. This prevents the pumps from blocking in case of a long shutdown.

Requirements for mixing valves

- Use 3-way mixing valves with the following flow characteristics:
 - Equal percentage control path
 - Linear bypass
- The valve authority must be ≥ 0.5 .
- The maximum run time of the valve actuator is 45 s.
- The valve actuator must be continuous, i.e. the stroke changes in proportion to the control voltage (0...10 VDC or 2...10 VDC).
- The valve actuator must be designed with a position response (0...10 VDC or 2...10 VDC).
- The maximum power consumption is 20 VA.
- Install the valve close to the unit (max. distance 2 m).



Notice

Use the 'Hydraulic assembly' or 'Mixing valve' options for quick and easy hydraulic installation.

Requirements on changeover valves

Use changeover valves conforming to the following specification:

- 3-way changeover valves
- Supply voltage 24 V AC
- 1-wire control (0/24 V AC)
- Position response via limit switches (0°/90°)
- Power consumption max. 44 VA

2.2 Condensate connection

Condensate arising in cooling units must be removed via a condensate-proof line.

- Install and insulate the supplied trap on the condensate connection of the unit.
- Dimension the slope and cross-section of the condensate line so that no condensate backflow takes place.
- Make sure that the condensate produced is drained in compliance with local regulations.
- Route the condensate line from the pump directly upwards.



Notice

Use the 'Condensate pump' option for quick and easy hydraulic installation.

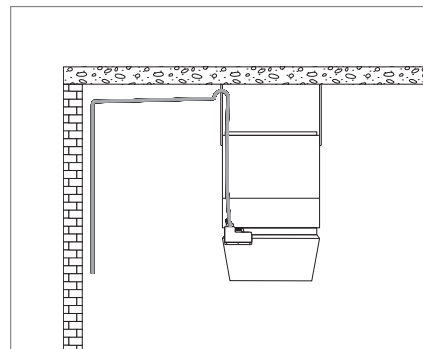

Fig. I1: Condensate drain

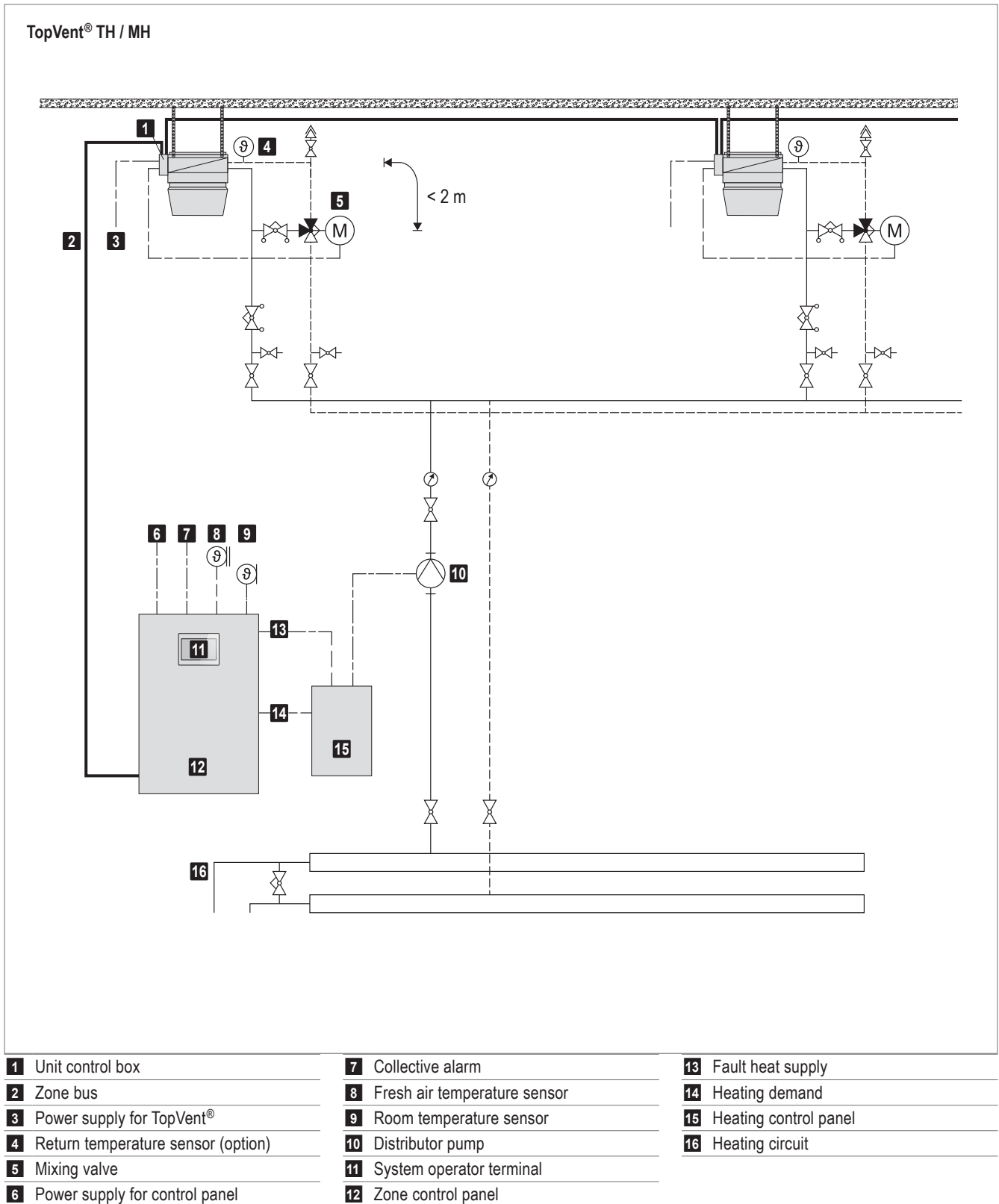

Fig. I2: Conceptual drawing for hydraulic diverting system TopVent® TH / MH

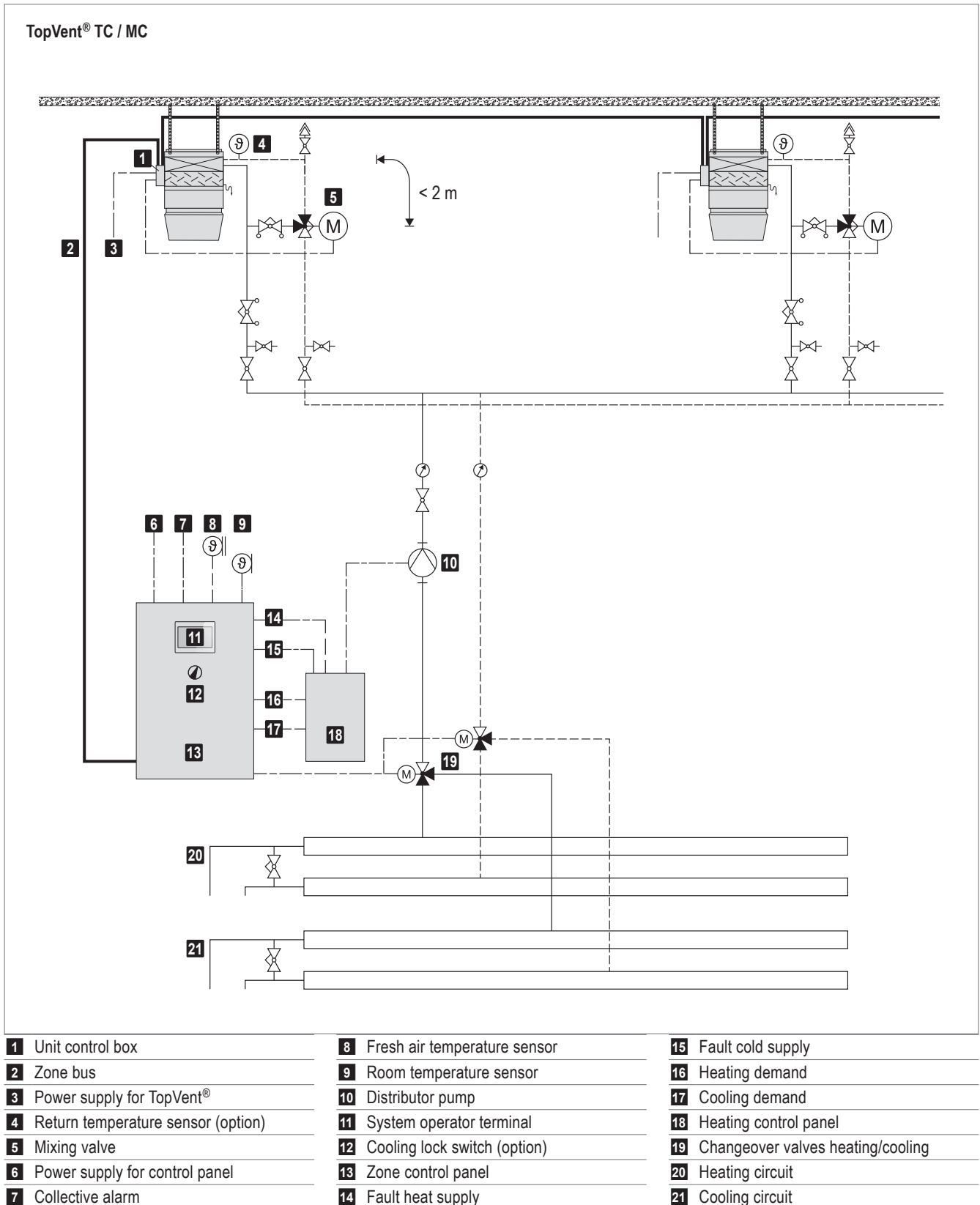

Fig. I3: Conceptual drawing for hydraulic diverting system TopVent® TC / MC

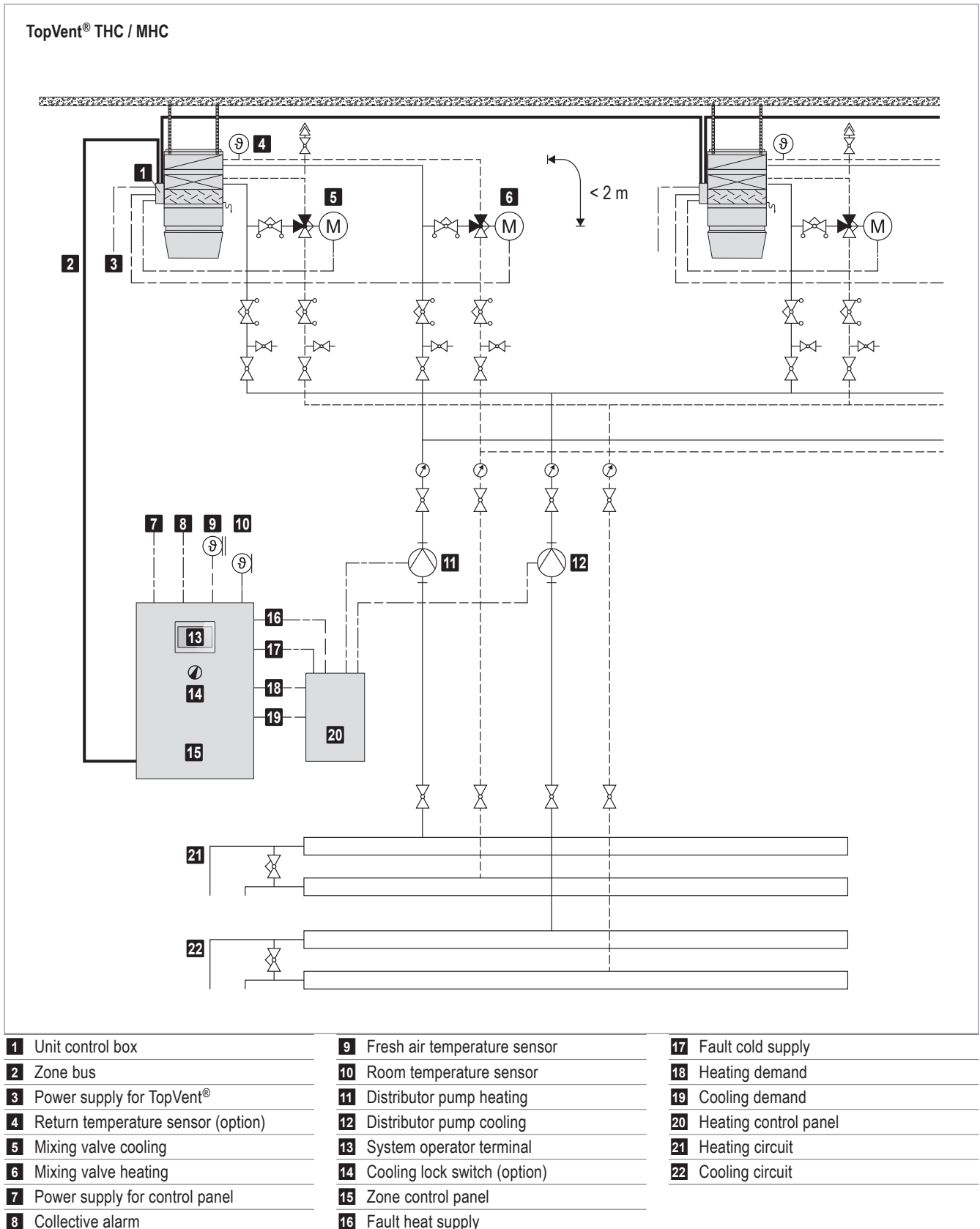

Fig. I4: Conceptual drawing for hydraulic diverting system TopVent® THC / MHC

3 Electrical installation

- The electrical installation must only be carried out by a qualified electrician.
- Observe the relevant regulations (e.g. EN 60204-1).
- Choose the dimensions of the cable cross sections in line with the applicable regulations.
- Route signal and bus lines separately from mains cables.
- Make sure the lightning protection system for the units or for the entire building is planned and carried out by professionals.
- Provide overload protection equipment on site in the mains connection line of the zone control panel.
- Carry out the electrical installation according to the wiring diagram:
 - Power supply for TopVent®
 - Zone bus based on system layout
 - Signal lines
- Connect optional components to the unit control box (condensate pump, return temperature sensor, mixing valve, pump).



Component	Designation	Voltage	Cable	Comments
TopTronic® C System control	Power supply	3 × 400 VAC	NYM-J 5 × ... mm ²	3-phase
		1 × 230 VAC	NYM-J 3 × ... mm ²	1-phase
Zone control panel	Zone bus		J-Y(St)Y 2 × 2 × 0.8 mm	max. 500 m length
	System bus		Ethernet ≥ CAT 5	For connecting several zone control panels
	Integration into the building management system		Ethernet ≥ CAT 5	BACnet, Modbus IP
		J-Y(St)Y 2 × 2 × 0.8 mm	Modbus RTU	
	Room temperature sensor		J-Y(St)Y 2 × 2 × 0.8 mm	max. 250 m
	Fresh air temperature sensor		J-Y(St)Y 2 × 2 × 0.8 mm	max. 250 m
	Additional room air temp. sensors		J-Y(St)Y 2 × 2 × 0.8 mm	max. 250 m
	Combination sensor room air quality, temperature and humidity		J-Y(St)Y 4 × 2 × 0.8 mm	max. 250 m
	Combination sensor fresh air temperature and humidity		J-Y(St)Y 2 × 2 × 0.8 mm	max. 250 m
	Collective alarm	Volt-free max. 230 VAC max. 24 VDC	NYM-O 2 × 1.5 mm ²	max. 3 A max. 2 A
Power supply for units		3 × 400 VAC	NYM-J 5 × 1.5 mm ² (min.)	RoofVent® units size 6
		3 × 400 VAC	NYM-J 5 × 4.0 mm ² (min.)	RoofVent® units size 9
		3 × 400 VAC	NYM-J 5 × 1.5 mm ² (min.)	TopVent® units
Heating demand		Volt-free	NYM-O 2 × 1.5 mm ²	max. 8 A
		max. 250 VAC max. 24 VDC		
Setpoint heating demand		2-10 VDC	J-Y(St)Y 2 × 2 × 0.8 mm	max. 250 m
Cooling demand		Volt-free	NYM-O 2 × 1.5 mm ²	max. 8 A
		max. 250 VAC		
		max. 24 VDC		
Fault heat supply		24 VAC	NYM-O 2 × 1.5 mm ²	max. 1 A
Fault cold supply		24 VAC	NYM-O 2 × 1.5 mm ²	max. 1 A
Distributor pump heat supply		3 × 400 VAC	NYM-J 4 × 1.5 mm ² (min.)	Power supply 3-phase, max. 6 A
		1 × 230 VAC	NYM-J 3 × 1.5 mm ² (min.)	Power supply 1-phase, max. 6 A
			NYM-O 4 × 1.5 mm ²	Control line
Distributor pump cold supply		3 × 400 VAC	NYM-J 4 × 1.5 mm ² (min.)	Power supply 3-phase, max. 6 A
		1 × 230 VAC	NYM-J 3 × 1.5 mm ² (min.)	Power supply 1-phase, max. 6 A
			NYM-O 4 × 1.5 mm ²	Control line
System operator terminal (if external)		24 VAC	NYM-J 3 × 1.5 mm ²	Power supply, 1 A fusing
			Ethernet ≥ CAT 5	Communication
Zone operator terminal (if external)		24 VAC	J-Y(St)Y 4 × 2 × 0.8 mm	max. 250 m length
External sensor values		0-10 VDC	J-Y(St)Y 2 × 2 × 0.8 mm	
External set values		0-10 VDC	J-Y(St)Y 2 × 2 × 0.8 mm	
Load shedding input		24 VAC	NYM-O 2 × 1.5 mm ²	max. 1 A
Operating selector switch on terminal (analogue)		0-10 VDC	J-Y(St)Y 2 × 2 × 0.8 mm	
Operating selector switch on terminal (digital)		0-10 VDC	J-Y(St)Y 6 × 2 × 0.8 mm	
Operating selector button on terminal		24 VAC	J-Y(St)Y 6 × 2 × 0.8 mm	
Forced off		24 VAC	NYM-O 2 × 1.5 mm ²	max. 1 A
External enabling or setting heating/cooling		24 VAC	NYM-O 2 × 1.5 mm ²	max. 1 A
Changeover valve flow		24 VAC	NYM-O 7 × 1.5 mm ²	
Changeover valve return		24 VAC	NYM-O 7 × 1.5 mm ²	

Component	Designation	Voltage	Cable	Comments	
TopTronic® C System control for TopVent® (C-SYS) Zone control panel	Power supply	1 × 230 VAC	NYM-J 3 × 1.5 mm ²	1-phase	
	Zone bus		J-Y(St)Y 2 × 2 × 0.8 mm	max. 500 m length	
	Integration into the building management system			Ethernet ≥ CAT 5	BACnet, Modbus IP
				J-Y(St)Y 2 × 2 × 0.8 mm	Modbus RTU
	Room temperature sensor		J-Y(St)Y 2 × 2 × 0.8 mm	max. 250 m	
	Fresh air temperature sensor		J-Y(St)Y 2 × 2 × 0.8 mm	max. 250 m	
	Additional room temperature sensors		J-Y(St)Y 2 × 2 × 0.8 mm	max. 250 m	
	Collective alarm	Volt-free max. 230 VAC max. 24 VDC	NYM-O 2 × 1.5 mm ²		max. 3 A max. 2 A
	Heating demand	Volt-free max. 250 VAC max. 24 VDC	NYM-O 2 × 1.5 mm ²		max. 8 A
	Setpoint heating demand	2-10 VDC	J-Y(St)Y 2 × 2 × 0.8 mm		max. 250 m
	Cooling demand	Volt-free max. 250 VAC max. 24 VDC	NYM-O 2 × 1.5 mm ²		max. 8 A
	Fault heat supply	24 VAC	NYM-O 2 × 1.5 mm ²		max. 1 A
	Fault cold supply	24 VAC	NYM-O 2 × 1.5 mm ²		max. 1 A
	External setpoint fresh air ratio	0-10 VDC	J-Y(St)Y 2 × 2 × 0.8 mm		
	Operating selector switch on terminal (digital)	0-10 VDC	J-Y(St)Y 6 × 2 × 0.8 mm		
	Operating selector button on terminal	24 VAC	J-Y(St)Y 6 × 2 × 0.8 mm		
	Forced off	24 VAC	NYM-O 2 × 1.5 mm ²		max. 1 A
External enabling or setting heating/cooling	24 VAC	NYM-O 2 × 1.5 mm ²		max. 1 A	
Changeover valve flow	24 VAC	NYM-O 7 × 1.5 mm ²			
Changeover valve return	24 VAC	NYM-O 7 × 1.5 mm ²			
TopVent® Ventilation unit	Power supply	3 × 400 VAC	NYM-J 5 × 1.5 mm ² (min.)	min. 7 m length	
	Zone bus		J-Y(St)Y 2 × 2 × 0.8 mm	max. 500 m length	
	Mixing valve heating	24 VAC	NYM-O 4 × 1.0 mm ²	with Hydraulic assembly or Mixing valve option: cable connected to the mixing valve	
	Mixing valve cooling	24 VAC	NYM-O 4 × 1.0 mm ²	with Hydraulic assembly or Mixing valve option: cable connected to the mixing valve	
	Heating pump	230 VAC	NYM-J 3 × 1.5 mm ²		Power supply
		24 VAC	NYM-O 4 × 1.0 mm ²		Control line
	Cooling pump	230 VAC	NYM-J 3 × 1.5 mm ²		Power supply
		24 VAC	NYM-O 4 × 1.0 mm ²		Control line
	Forced off	24 VAC	NYM-O 2 × 1.5 mm ²		max. 1 A (for MH, MC, MHC)
Door contact	24 VAC	NYM-O 2 × 1.0 mm ²		max. 1 A (for TH, TC)	

Table I2: Cable list for on-site connections – TopTronic® C

Component	Designation	Voltage	Cable	Comments
EasyTronic EC Controller	Power supply	1 × 230 VAC	NYM 2 × 1.5 mm ² (min.)	
	System bus		J-Y(St)Y 4 × 2 × 0.8 mm	Fan, air distribution
	External room temperature sensor		J-Y(St)Y 2 × 2 × 0.8 mm	Shielded, max. 30 m length
	Door contact	24 VDC	NYM 2 × 1.0 mm ²	
	Pump / Valve control	230 VAC 24 VDC	depending on the number of contacts	Via field-supplied relay, max 3 A
	Heating/cooling changeover	24 VAC	NYM-O 2 × 1.5 mm ²	max. 1 A
	Modbus RTU		J-Y(ST)Y 2 × 2 × 0.8 mm	max. 300 m length
TopVent® Terminal box design	Power supply	3 × 400 VAC	NYM-J 5 × 1.5 mm ² (min.)	min. 7 m length
	System bus		J-Y(St)Y 4 × 2 × 0.8 mm	Fan, air distribution
	Differential pressure switch air filter		NYM 2 × 1.0 mm ²	Signal to a field-supplied lamp or controller

Table I3: Cable list for on-site connections – EasyTronic EC

Actuator Air-Injector	
Control voltage	2...10 VDC
Control range	2 - 6.44 V / 0° - 50°
Position response	2...10 VDC
Fan	
Enable signal	digital
Control voltage	0...10 VDC
Air filter (option)	
Signal differential pressure switch	digital

Table I4: Control signals for TopVent® in terminal box design



System design

1 Design example	110
2 Maintenance schedule	112
3 Checklist for project discussions	113

1 Design example



Notice

Use the 'HK-Select' program to design Hoval Indoor Climate Systems. You can download it free of charge on the Internet.

Design data	Example
<ul style="list-style-type: none"> ■ Geometry of the room ■ Internal heat gains ■ People in the room ■ Heating and cooling with central energy supply (boiler and water chiller) ■ Improvement of air quality, fresh air supply for the people in the room (fresh air flow rate per person = 30 m³/h) 	<p>50 × 60 × 12 m 28 kW 20 people</p>
<p>Design conditions heating:</p> <ul style="list-style-type: none"> ■ Fabric heat losses ■ Fresh air temperature ■ Room temperature ■ Extract air temperature ■ Temperature of the heating medium 	<p>350 kW - 15 °C 18 °C 20 °C 60 °C / 40 °C</p>
<p>Design conditions cooling:</p> <ul style="list-style-type: none"> ■ Transmission sensible gains ■ Fresh air conditions ■ Room air conditions ■ Extract air temperature ■ Temperature of the cooling medium 	<p>140 kW 32 °C / 40 %rh 26 °C / 40 %rh 28 °C 6 °C / 12 °C</p>
<p>Fresh air supply</p> <ul style="list-style-type: none"> ■ Required fresh air flow rate in total: ■ Fresh air ratio of supply air units: max. 10 % of the nominal air flow rate <p><i>The fresh air ratio can be adjusted from 0...100 %. Where EU Regulation 1253/2014 applies, it must be restricted to max. 10 % in the design conditions.</i></p> <ul style="list-style-type: none"> ■ Calculate the required number of supply air units from the nominal air flow rate. 	<p>20 × 30 = 600 m³/h</p> <p>Size 6: max. 600 m³/h fresh air Size 9: max. 900 m³/h fresh air</p> <p>→ 1 TopVent® MC unit</p>
<p>Mounting height</p> <ul style="list-style-type: none"> ■ Calculate the actual mounting height (= distance between the floor and the bottom edge of the units). <p><i>Y = Hall height – distance from ceiling – unit height</i></p> <ul style="list-style-type: none"> ■ Compare the actual mounting height with the minimum and maximum mounting height (see Table I1 on page 100 and HK-Select). 	<p><u>Supply air units:</u> Size 6 → OK Size 9 → OK</p> <p><u>Recirculation units:</u> Size 6 → OK Size 9 → OK</p>

Required performance for covering fabric heat losses / transmission sensible gains																																																																					
<ul style="list-style-type: none"> Required heat output for coverage of fabric heat losses in total: $Q_{H_req} = \text{Fabric heat losses} - \text{internal heat loads}$ 	350 – 28 = 322 kW																																																																				
<ul style="list-style-type: none"> Required cooling capacity for coverage of transmission sensible gains in total: $Q_{C_req} = \text{Transmission sensible gains} + \text{internal heat loads}$ 	140 + 28 = 168 kW																																																																				
<p>Required heat output of recirculation units</p> <ul style="list-style-type: none"> Determine the required heat output of the recirculation units based on the output of the supply air unit. $Q_{H_Recirculation} = Q_{H_req} - Q_{H_Supply\ air}$ <p><i>For the supply air unit, take into account only the share of capacity that is used for coverage of fabric heat losses (separately shown in HK-Select).</i></p>	<table border="1"> <thead> <tr> <th>Type</th> <th>$Q_{H_Supply\ air}$</th> <th>$Q_{H_Recirculation}$</th> </tr> </thead> <tbody> <tr> <td>MC-6/C</td> <td>40.5</td> <td>322 – 40.5 = 281.5</td> </tr> <tr> <td>MC-9/C</td> <td>63.2</td> <td>322 – 63.2 = 258.8</td> </tr> <tr> <td>MC-9/D</td> <td>79.3</td> <td>322 – 79.3 = 242.7</td> </tr> </tbody> </table> <p>(values in kW)</p>	Type	$Q_{H_Supply\ air}$	$Q_{H_Recirculation}$	MC-6/C	40.5	322 – 40.5 = 281.5	MC-9/C	63.2	322 – 63.2 = 258.8	MC-9/D	79.3	322 – 79.3 = 242.7																																																								
Type	$Q_{H_Supply\ air}$	$Q_{H_Recirculation}$																																																																			
MC-6/C	40.5	322 – 40.5 = 281.5																																																																			
MC-9/C	63.2	322 – 63.2 = 258.8																																																																			
MC-9/D	79.3	322 – 79.3 = 242.7																																																																			
<p>Required cooling capacity of recirculation units</p> <ul style="list-style-type: none"> Determine the required cooling capacity of the recirculation units based on the capacity of the supply air unit. $Q_{C_Recirculation} = Q_{C_req} - Q_{C_Supply\ air}$ <p><i>For the supply air unit, take into account only the share of capacity that is used for coverage of transmission sensible gains (separately shown in HK-Select).</i></p>	<table border="1"> <thead> <tr> <th>Type</th> <th>$Q_{C_Supply\ air}$</th> <th>$Q_{C_Recirculation}$</th> </tr> </thead> <tbody> <tr> <td>MC-6/C</td> <td>25.4</td> <td>168 – 25.4 = 142.6</td> </tr> <tr> <td>MC-9/C</td> <td>39.2</td> <td>168 – 39.2 = 128.8</td> </tr> <tr> <td>MC-9/D</td> <td>46.7</td> <td>168 – 46.7 = 121.3</td> </tr> </tbody> </table> <p>(values in kW)</p>	Type	$Q_{C_Supply\ air}$	$Q_{C_Recirculation}$	MC-6/C	25.4	168 – 25.4 = 142.6	MC-9/C	39.2	168 – 39.2 = 128.8	MC-9/D	46.7	168 – 46.7 = 121.3																																																								
Type	$Q_{C_Supply\ air}$	$Q_{C_Recirculation}$																																																																			
MC-6/C	25.4	168 – 25.4 = 142.6																																																																			
MC-9/C	39.2	168 – 39.2 = 128.8																																																																			
MC-9/D	46.7	168 – 46.7 = 121.3																																																																			
<p>Minimum number of recirculation units</p> <ul style="list-style-type: none"> Determine the minimum number of recirculation units depending on the available supply air units. Take into account the following criteria: <ul style="list-style-type: none"> Floor area covered Heat output Cooling capacity Unit clearances 																																																																					
<table border="1"> <thead> <tr> <th rowspan="2">Supply air unit</th> <th rowspan="2">Recirculation units</th> <th colspan="4">Required number of recirculation units</th> <th rowspan="2">Minimum number of recirculation units</th> </tr> <tr> <th>Floor area covered</th> <th>Heat output</th> <th>Cooling capacity</th> <th>Unit clearances</th> </tr> </thead> <tbody> <tr> <td rowspan="3">1 unit MC-6/C</td> <td>TC-6/C</td> <td>5</td> <td>7</td> <td>6</td> <td>5</td> <td>7</td> </tr> <tr> <td>TC-9/C</td> <td>3</td> <td>5</td> <td>4</td> <td>5</td> <td>5</td> </tr> <tr> <td>TC-9/D</td> <td>3</td> <td>4</td> <td>3</td> <td>5</td> <td>5</td> </tr> <tr> <td rowspan="3">1 unit MC-9/C</td> <td>TC-6/C</td> <td>4</td> <td>7</td> <td>5</td> <td>5</td> <td>7</td> </tr> <tr> <td>TC-9/C</td> <td>3</td> <td>4</td> <td>4</td> <td>3</td> <td>4</td> </tr> <tr> <td>TC-9/D</td> <td>3</td> <td>4</td> <td>3</td> <td>3</td> <td>4</td> </tr> <tr> <td rowspan="3">1 unit MC-9/D</td> <td>TC-6/C</td> <td>4</td> <td>6</td> <td>5</td> <td>5</td> <td>6</td> </tr> <tr> <td>TC-9/C</td> <td>3</td> <td>4</td> <td>≈ 3 (-1 kW)</td> <td>3</td> <td>4</td> </tr> <tr> <td>TC-9/D</td> <td>3</td> <td>≈ 3 (-2 kW)</td> <td>3</td> <td>3</td> <td>3</td> </tr> </tbody> </table>	Supply air unit	Recirculation units	Required number of recirculation units				Minimum number of recirculation units	Floor area covered	Heat output	Cooling capacity	Unit clearances	1 unit MC-6/C	TC-6/C	5	7	6	5	7	TC-9/C	3	5	4	5	5	TC-9/D	3	4	3	5	5	1 unit MC-9/C	TC-6/C	4	7	5	5	7	TC-9/C	3	4	4	3	4	TC-9/D	3	4	3	3	4	1 unit MC-9/D	TC-6/C	4	6	5	5	6	TC-9/C	3	4	≈ 3 (-1 kW)	3	4	TC-9/D	3	≈ 3 (-2 kW)	3	3	3	
Supply air unit			Recirculation units	Required number of recirculation units				Minimum number of recirculation units																																																													
	Floor area covered	Heat output		Cooling capacity	Unit clearances																																																																
1 unit MC-6/C	TC-6/C	5	7	6	5	7																																																															
	TC-9/C	3	5	4	5	5																																																															
	TC-9/D	3	4	3	5	5																																																															
1 unit MC-9/C	TC-6/C	4	7	5	5	7																																																															
	TC-9/C	3	4	4	3	4																																																															
	TC-9/D	3	4	3	3	4																																																															
1 unit MC-9/D	TC-6/C	4	6	5	5	6																																																															
	TC-9/C	3	4	≈ 3 (-1 kW)	3	4																																																															
	TC-9/D	3	≈ 3 (-2 kW)	3	3	3																																																															
<ul style="list-style-type: none"> Choose the final solution from the remaining possibilities, depending on the geometry of the hall and the costs. 																																																																					

2 Maintenance schedule

Activity	Interval
Renew air filter	When the filter alarm is displayed, at least annually
Comprehensively checking function; cleaning and possibly repairing the TopVent® units	Annually by Hoval customer service

Table J1: Maintenance schedule

Project

Project No.

Date

Name

Function

Address

Tel.

Fax

E-mail

Information about the hall

Application

Type

Insulation

Length

Width

Height

Is the roof strong enough?

yes no

Are there window areas?

yes no Percentage?

Is there a crane?

yes no Height?

Is there enough space for installation and servicing?

yes no

Are there any voluminous installations or machines?

yes no

Are pollutants present?

yes no Which?

– If yes, are they heavier than air?

yes no

Is oil contained in the extract air?

yes no

Is dust present?

yes no Dust level?

Is there high humidity?

yes no How much?

Are local machine extractions required?

yes no

Are any conditions imposed by public authorities?

yes no Which?

Are sound level requirements to be fulfilled?

yes no Which?

Design data

Internal heat gains (machines, ...) kW

Heating and cooling

Unit size

Control zones

Design conditions heating

- Standard outside temperature °C
- Room temperature °C
- Extract air temperature °C
- Fabric heat losses kW

Design conditions cooling

- Standard outside temperature °C
- Room temperature and humidity °C %
- Extract air temperature °C
- Transmission sensible gains kW

Further information

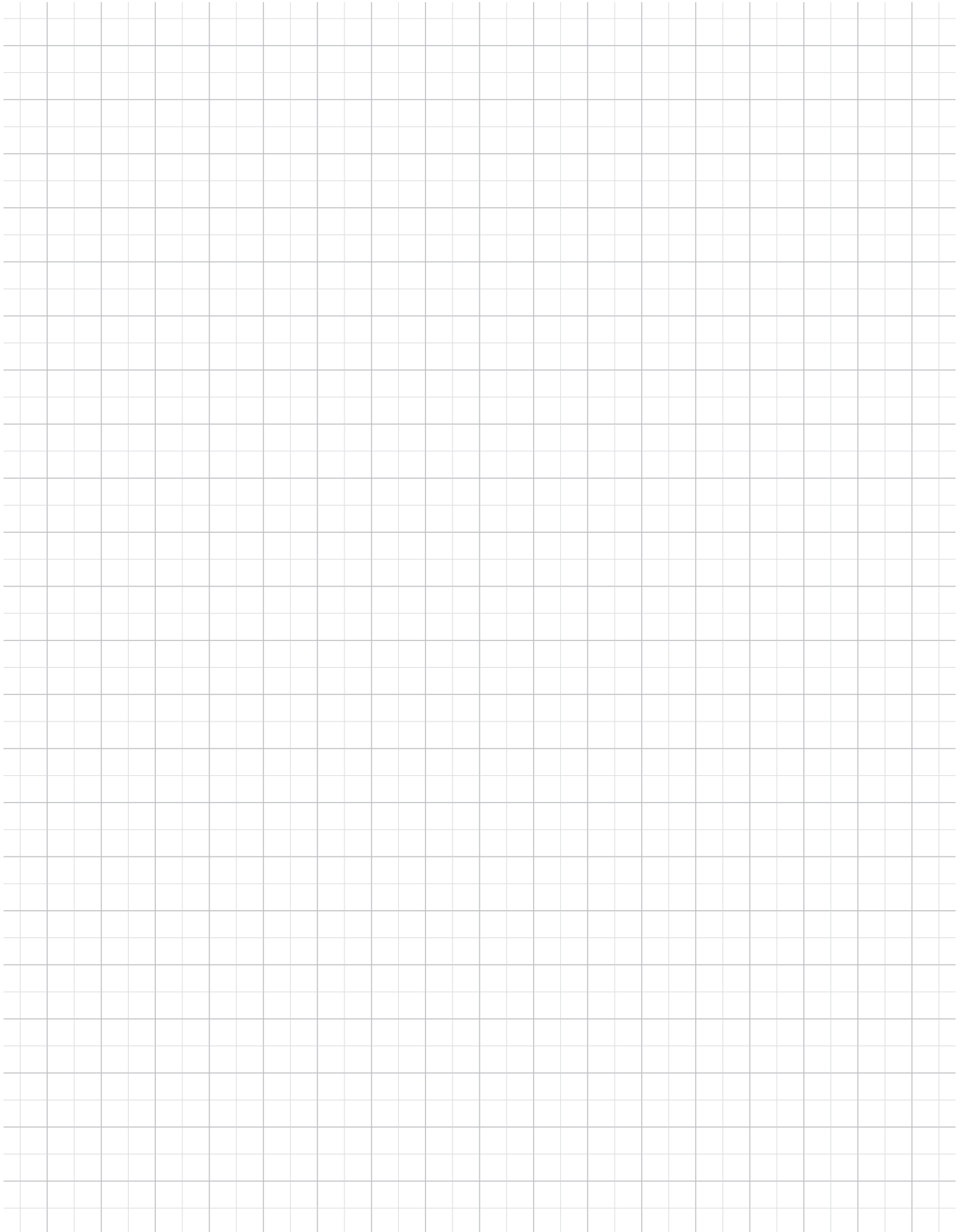

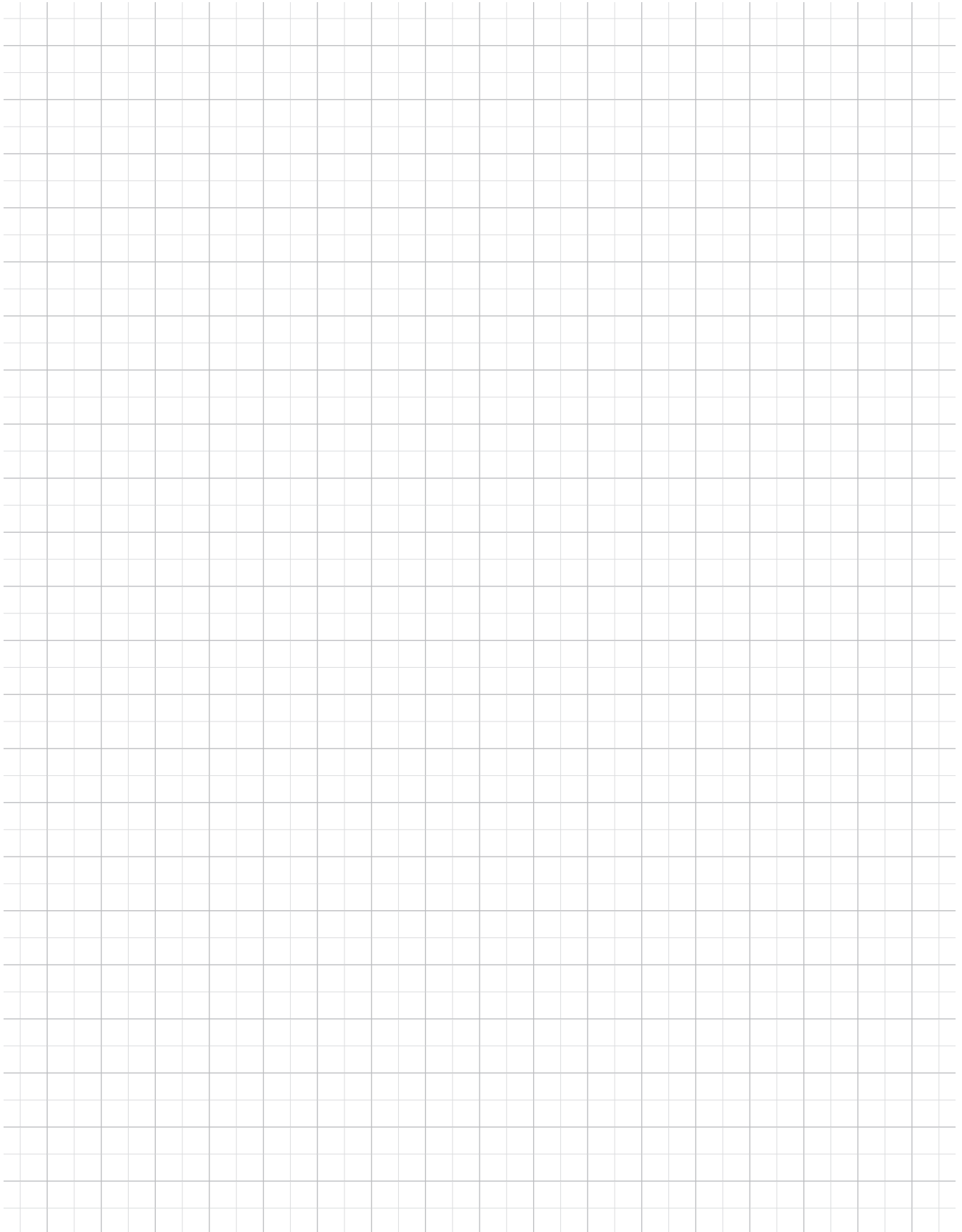

Hoval quality. You can count on us.

As a specialist in heating and air-conditioning technology, Hoval is your experienced partner for system solutions. For example, you can heat water with the sun's energy and the rooms with oil, gas, wood or a heat pump. Hoval ties together the various technologies and also integrates room ventilation into this system. You can be sure to save both energy and costs while protecting the environment.

Hoval is one of the leading international companies for indoor climate solutions. More than 70 years of experience continuously motivates us to design innovative system solutions. We export complete systems for heating, cooling and ventilation to more than 50 countries.

We take our responsibility for the environment seriously. Energy efficiency is at the heart of the heating and ventilation systems we design and develop.

Responsibility for energy and environment

United Kingdom
Hoval Ltd.
Northgate, Newark
Nottinghamshire
NG24 1JN
hoval.co.uk



Hoval Aktiengesellschaft | Austrasse 70 | 9490 Vaduz | hoval.com

Edition 2021-09 | 4220914

Hoval – your partner

Hoval

The background of the bottom section features a scenic landscape with snow-capped mountains, a lake, and a bright sun on the left, transitioning to a dark, stormy sky with lightning on the right. The Hoval logo is positioned in the bottom right corner of this section.