

## Hoval TopVent®

CH | CC | CHC | SH | SC | SHC

Operating instructions

Original  
operating manual  
4 221 492-en-01



<b>1 Use</b>	<b>3</b>		
1.1 Intended use . . . . .	3	7.7 Supply air silencer . . . . .	34
1.2 User group . . . . .	3	7.8 Hydraulic assembly throttling circuit. . . . .	34
<b>2 Safety</b>	<b>4</b>	7.9 Pump control . . . . .	34
2.1 Symbols . . . . .	4	7.10 Roof frame . . . . .	35
2.2 Operational safety . . . . .	4	7.11 Protection hood . . . . .	35
<b>3 Construction and operation</b>	<b>5</b>	<b>8 Transport and installation</b>	<b>36</b>
3.1 Components . . . . .	5	8.1 Scope of delivery . . . . .	36
3.2 TopVent® CH . . . . .	6	8.2 Storage. . . . .	37
3.3 TopVent® CC . . . . .	7	8.3 Requirements for the installation site . . . . .	37
3.4 TopVent® CHC . . . . .	8	8.4 Installation . . . . .	38
3.5 TopVent® SH . . . . .	9	8.5 Connecting air ducts. . . . .	43
3.6 TopVent® SC . . . . .	10	8.6 Hydraulic installation . . . . .	44
3.7 TopVent® SHC . . . . .	11	8.7 Electrical installation. . . . .	46
<b>4 Operating modes</b>	<b>12</b>	<b>9 Operation</b>	<b>50</b>
<b>5 Type code</b>	<b>14</b>	9.1 Initial commissioning . . . . .	50
<b>6 Technical data</b>	<b>18</b>	9.2 Operation . . . . .	50
6.1 Application limits . . . . .	18	<b>10 Maintenance and repair</b>	<b>51</b>
6.2 Electrical connection . . . . .	18	10.1 Safety . . . . .	51
6.3 Air flow rate . . . . .	18	10.2 Opening and closing access doors . . . . .	52
6.4 Air filtration . . . . .	18	10.3 Maintenance . . . . .	53
6.5 Heat output . . . . .	19	10.4 Repair. . . . .	53
6.6 Cooling capacity . . . . .	19	<b>11 Dismantling</b>	<b>54</b>
6.7 Dimensions and weights . . . . .	20	<b>12 Disposal</b>	<b>54</b>
6.8 Sound level . . . . .	32		
<b>7 Options</b>	<b>33</b>		
7.1 Connection module . . . . .	33		
7.2 Design without Air-Injector . . . . .	33		
7.3 Air distribution box . . . . .	33		
7.4 Outlet nozzle . . . . .	34		
7.5 Coating of roof unit . . . . .	34		
7.6 Paint finish of below-roof unit . . . . .	34		

# 1 Use

## 1.1 Intended use

### TopVent® CH, CC, CHC recirculation units

These TopVent® units are recirculation units for heating and cooling spaces up to 25 m in height with central heat and cold supply. They have the following functions:

- Heating (with connection to a hot water supply)
- Cooling (with connection to a water chiller) (only CC, CHC)
- Recirculation operation
- Air distribution and destratification with adjustable Air-Injector
- Air filtration

TopVent® CH, CC and CHC units comply with all the requirements of the Ecodesign Directive 2009/125/EC relating to environmentally friendly design of energy-related products. They are systems of the 'fan coil unit' type, provided for in Commission Regulation (EU) 2016/2281.

### TopVent® SH, SC, SHC supply air units

These TopVent® units are supply air units for ventilating, heating and cooling spaces up to 25 m in height with central heat and cold supply. They have the following functions:

- Heating (with connection to a hot water supply)
- Cooling (with connection to a water chiller) (only SC, SHC)
- Fresh air supply
- Mixed air operation
- Recirculation operation
- Air distribution and destratification with adjustable Air-Injector
- Air filtration

TopVent® SH, SC and SHC units comply with all the requirements of the Ecodesign Directive 2009/125/EC relating to environmentally friendly design of ventilation systems. They are systems of the 'non-residential ventilation unit' (NRVU) and 'unidirectional ventilation unit' (UVU) type, provided for in Commission Regulation (EU) 1253/2014.

Intended use also includes compliance with the operating instructions. Any usage over and above this use is considered to be not as intended. The manufacturer can accept no liability for damage resulting from improper use.

## 1.2 User group

The units are only allowed to be installed, operated and maintained by authorised and instructed personnel who are well acquainted with the units and are informed about possible dangers.

The operating instructions are for operating engineers as well as specialists in building, heating and ventilation technology.

## 2 Safety

### 2.1 Symbols

**Caution**

This symbol warns against risk of injury. Please heed all instructions designated by this symbol to prevent injuries and/or death.

**Attention**

This symbol warns against property damage. Please heed the respective instructions to prevent risk of damage to the unit and its functions.

**Notice**

This symbol denotes information about the economic use of the equipment or special tips.

### 2.2 Operational safety

TopVent® units are state-of-the-art and safe to operate. All control and safety valves are checked at the factory. Nevertheless, hazards may emanate from the units if they are used incorrectly or not used as intended. Therefore:

- The unit may only be installed, operated and serviced by authorised, trained and instructed skilled personnel:
  - Specialists as defined by these operating instructions are those persons who, based on their training, knowledge and experience as well as their knowledge of the relevant regulations and guidelines, can carry out the work assigned to them and recognise potential hazards.
- Please read the operating instructions before unpacking, installing, commissioning and before maintaining the equipment.
- Store the operating instructions so that they are easily accessible.
- Observe any attached information and warning signs.
- Immediately replace damaged or removed informational and warning signs.
- Follow the local safety and accident prevention regulations at all times.
- Observe the particular dangers involved in working on the roof and on electrical systems.
- When working on the unit, objects (e.g. tools) could be dropped. Block off the area underneath the unit.
- Do not attach additional loads to the unit.
- When working in the unit, take precautions against unprotected, sharp metal edges.
- Observe the dangers involved when working on the hot water supply.
- Wear suitable protective equipment (helmet, gloves, mouth protection, goggles).
- Following maintenance work, professionally reassemble all dismantled protective devices.
- Ensure that all access doors are properly closed to prevent water entry through the roof unit.
- Make sure that hot water is available to avoid damage to the unit due to icing of the coil.
- Replacement parts must comply with the technical requirements of the system manufacturer. Hoval recommends the use of original spare parts.

- Unauthorised reconfiguration or modification of the unit is not permitted.
- Shut down the unit immediately, if any defects are ascertained that limit the operational safety.

### 3 Construction and operation

#### 3.1 Components

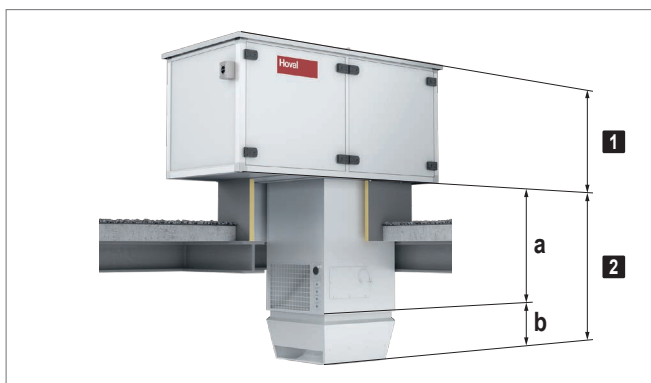

- 1** Roof unit
- 2** Below-roof unit
  - a** Connection module
  - b** Air-Injector

Fig. 1: Components

3.2 TopVent® CH

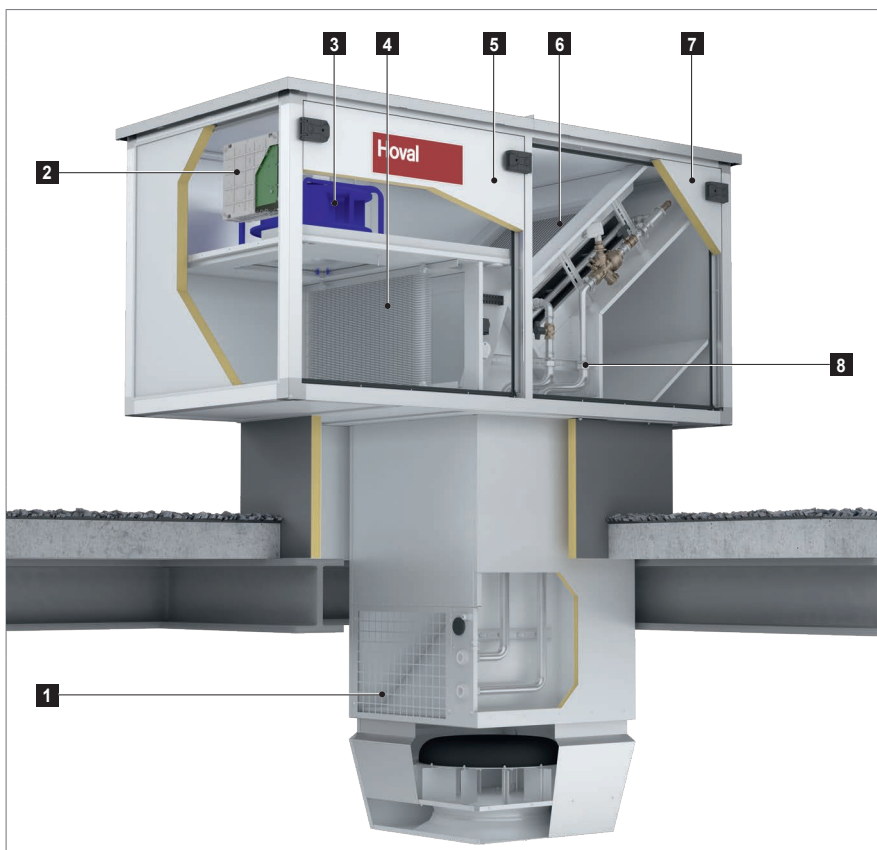

- 1 Extract air grille
- 2 Unit control box
- 3 Fan
- 4 Extract air filter
- 5 Fan access door
- 6 Heating coil
- 7 Hydraulic connection access door
- 8 Hydraulic assembly throttling circuit

Fig. 2: TopVent® CH construction

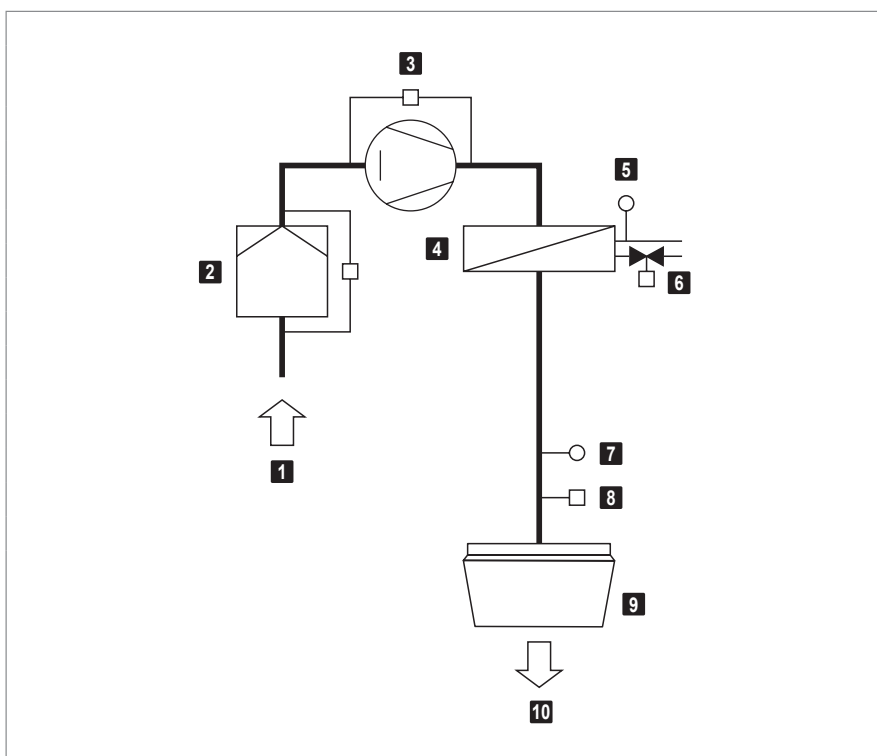

- 1 Extract air
- 2 Extract air filter with differential pressure switch
- 3 Fan with flow rate monitoring
- 4 Heating coil
- 5 Return temperature sensor
- 6 Control valve with actuator (option)
- 7 Supply air temperature sensor
- 8 Actuator Air-Injector
- 9 Air-Injector
- 10 Supply air

Fig. 3: TopVent® CH function diagram

3.3 TopVent® CC

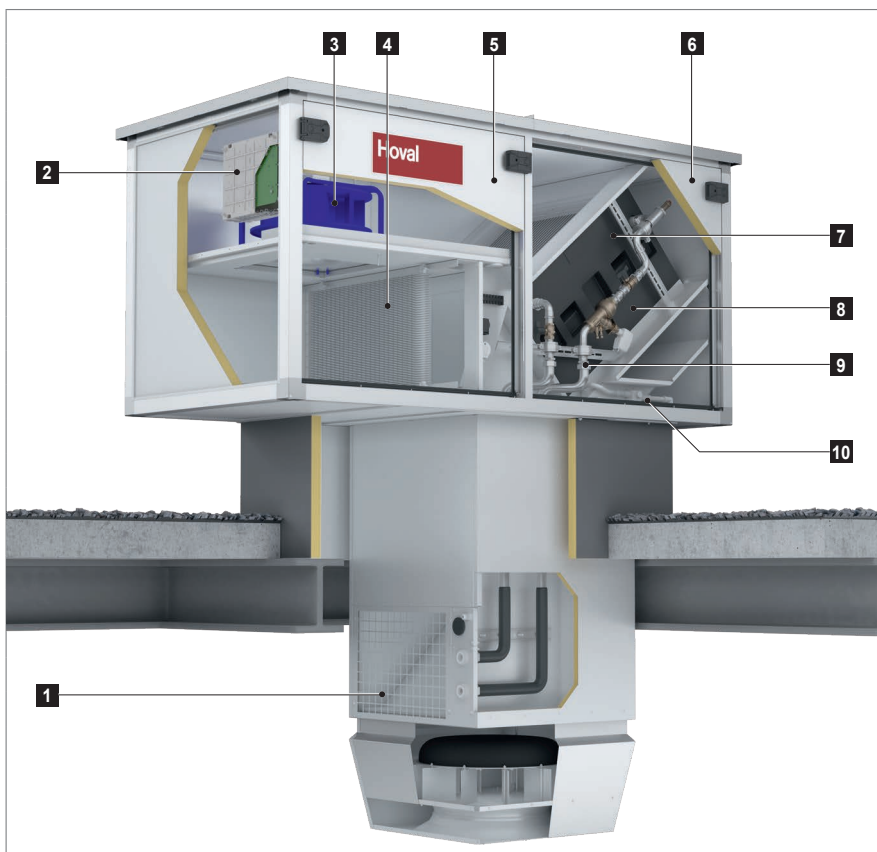

- 1 Extract air grille
- 2 Unit control box
- 3 Fan
- 4 Extract air filter
- 5 Fan access door
- 6 Hydraulic connection access door
- 7 Heating/cooling coil
- 8 Condensate separator
- 9 Hydraulic assembly throttling circuit
- 10 Condensate drain

Fig. 4: TopVent® CC construction

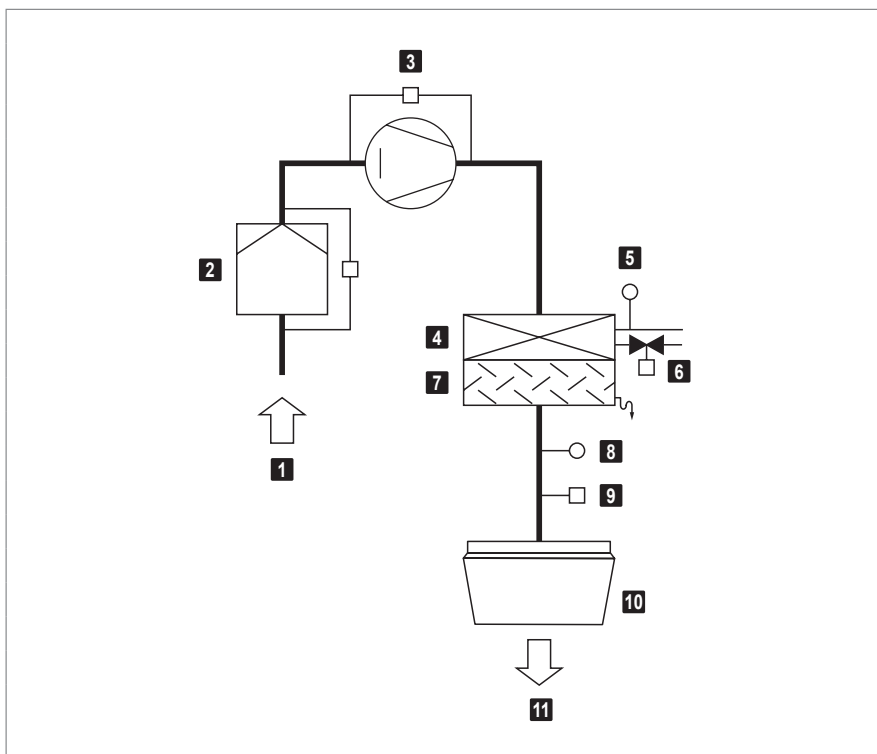

- 1 Extract air
- 2 Extract air filter with differential pressure switch
- 3 Fan with flow rate monitoring
- 4 Heating/cooling coil
- 5 Return temperature sensor
- 6 Control valve with actuator (option)
- 7 Condensate separator
- 8 Supply air temperature sensor
- 9 Actuator Air-Injector
- 10 Air-Injector
- 11 Supply air

Fig. 5: TopVent® CC function diagram

3.4 TopVent® CHC

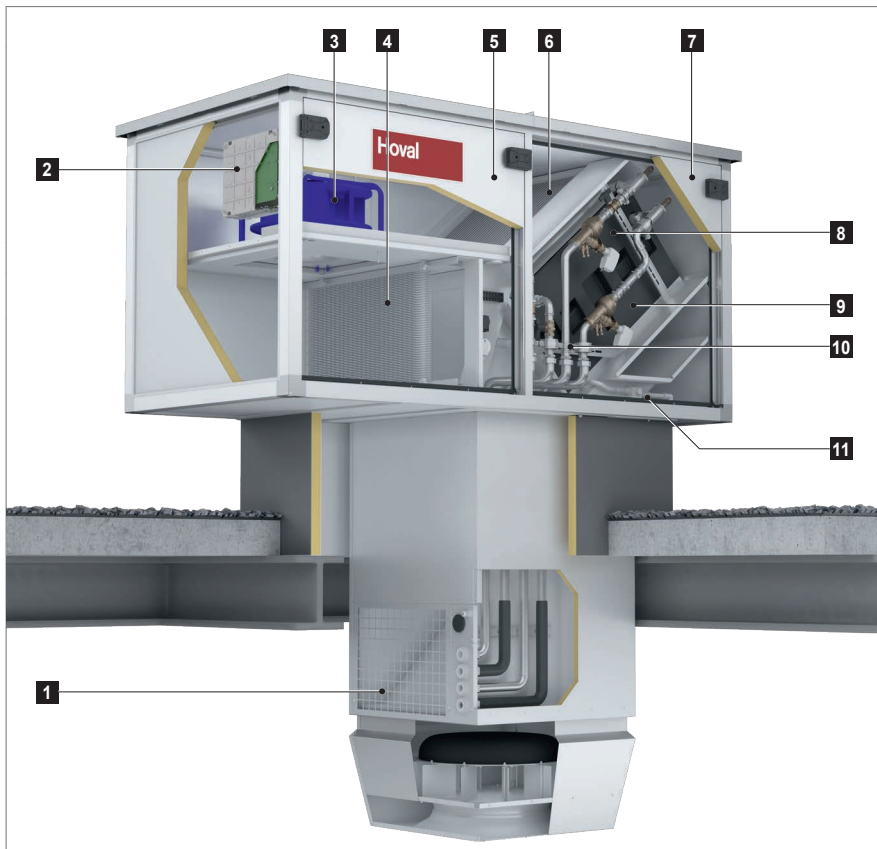

- 1 Extract air grille
- 2 Unit control box
- 3 Fan
- 4 Extract air filter
- 5 Fan access door
- 6 Heating coil
- 7 Hydraulic connection access door
- 8 Cooling coil
- 9 Condensate separator
- 10 Hydraulic assembly throttling circuit
- 11 Condensate drain

Fig. 6: TopVent® CHC construction

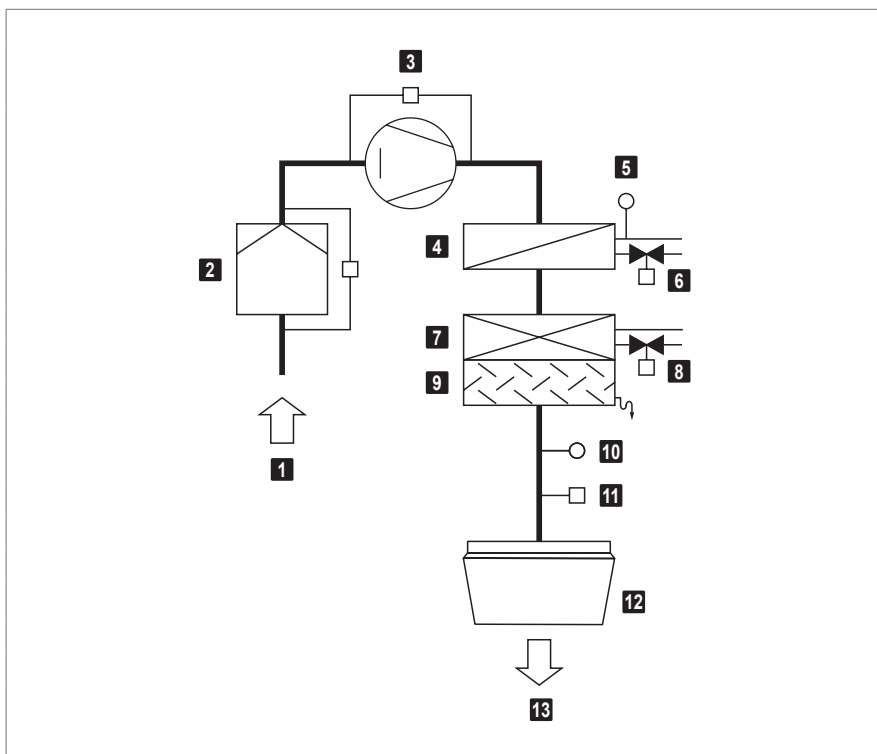

- 1 Extract air
- 2 Extract air filter with differential pressure switch
- 3 Fan with flow rate monitoring
- 4 Heating coil
- 5 Return temperature sensor
- 6 Control valve with actuator (option)
- 7 Cooling coil
- 8 Control valve with actuator (option)
- 9 Condensate separator
- 10 Supply air temperature sensor
- 11 Actuator Air-Injector
- 12 Air-Injector
- 13 Supply air

Fig. 7: TopVent® CHC function diagram



3.5 TopVent® SH

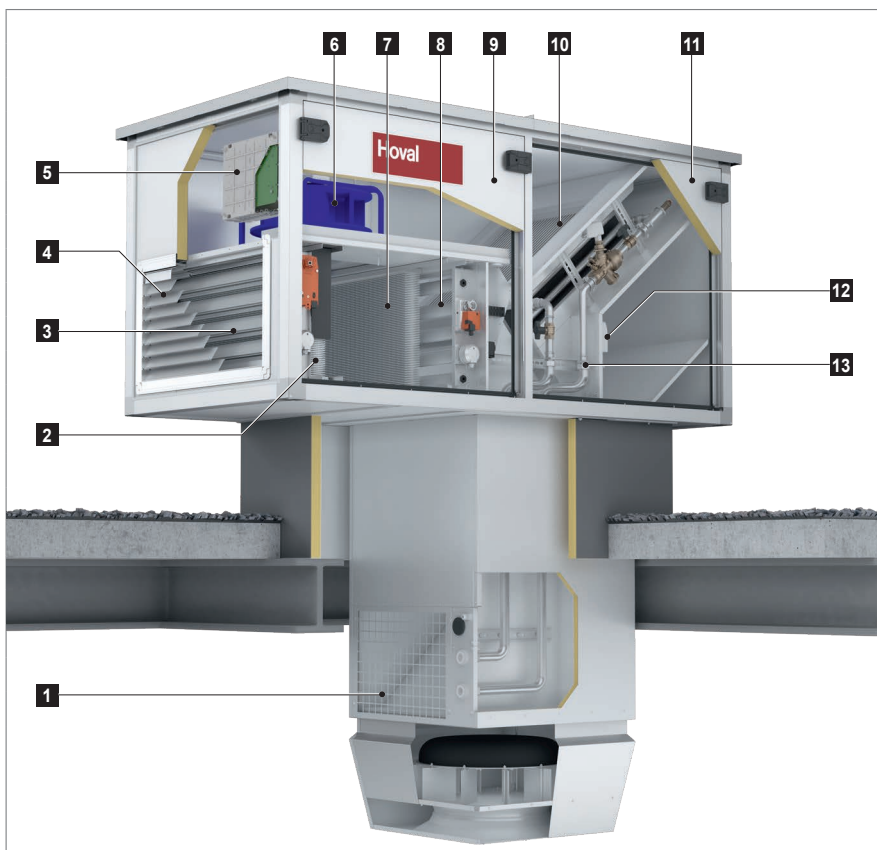

- 1 Extract air grille
- 2 Fresh air filter
- 3 Fresh air damper
- 4 Weather protection
- 5 Unit control box
- 6 Fan
- 7 Extract air filter
- 8 Recirculation damper
- 9 Fan access door
- 10 Heating coil
- 11 Hydraulic connection access door
- 12 Frost controller
- 13 Hydraulic assembly throttling circuit

Fig. 8: TopVent® SH construction

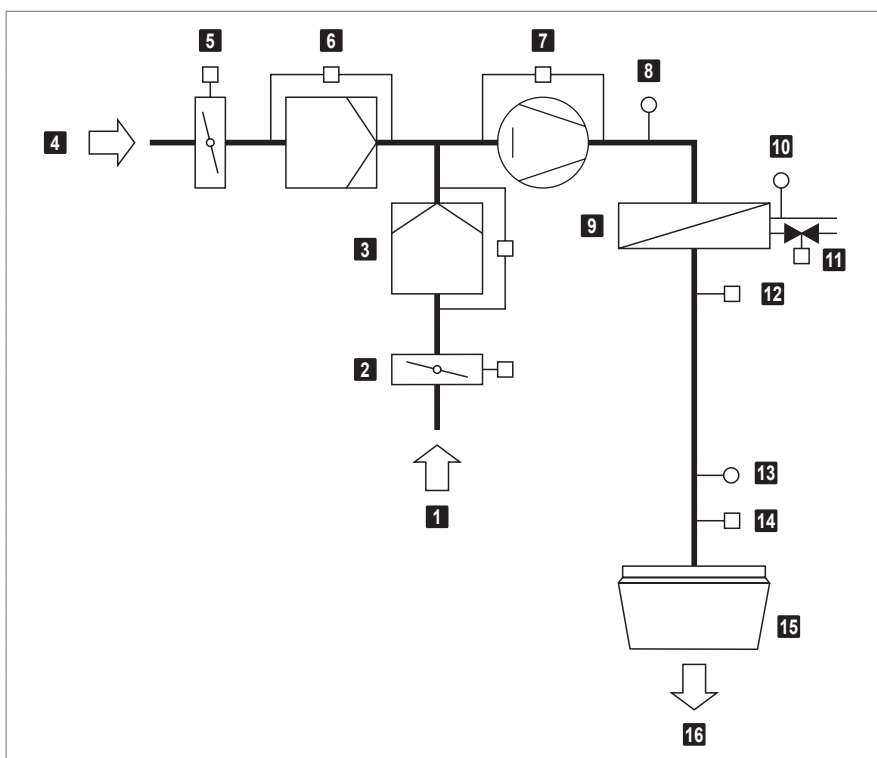

- 1 Extract air
- 2 Recirculation damper with actuator
- 3 Extract air filter with differential pressure switch
- 4 Fresh air
- 5 Fresh air damper with actuator
- 6 Fresh air filter with differential pressure switch
- 7 Fan with flow rate monitoring
- 8 Mixed air temperature sensor
- 9 Heating coil
- 10 Return temperature sensor
- 11 Control valve with actuator (option)
- 12 Frost controller
- 13 Supply air temperature sensor
- 14 Actuator Air-Injector
- 15 Air-Injector
- 16 Supply air

Fig. 9: TopVent® SH function diagram

3.6 TopVent® SC

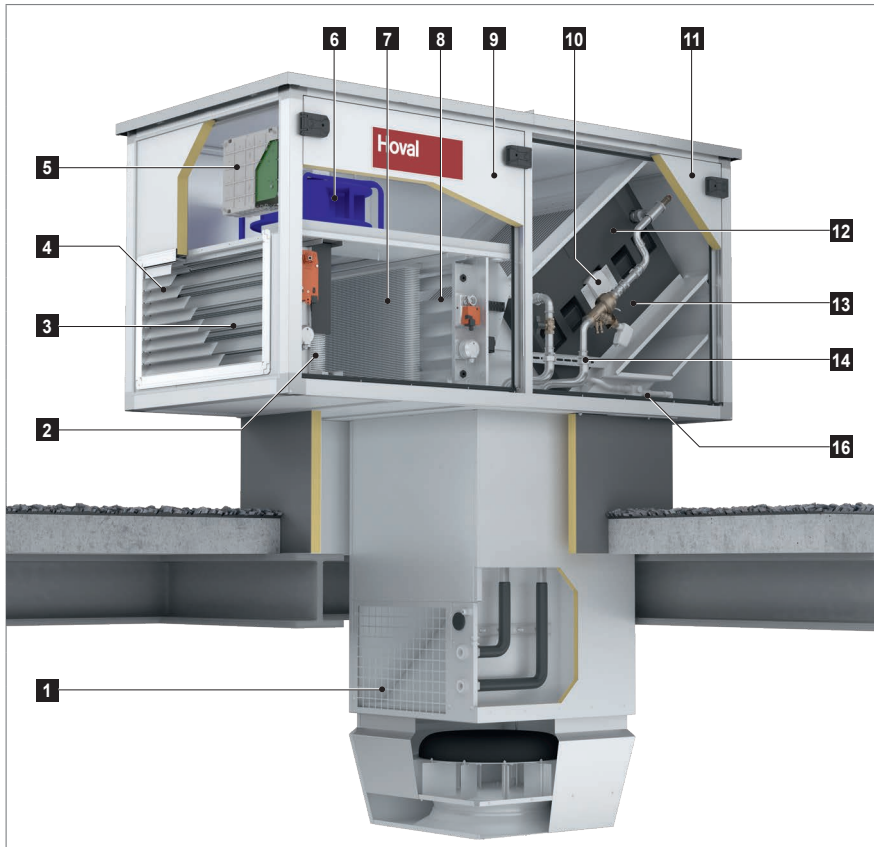

- 1 Extract air grille
- 2 Fresh air filter
- 3 Fresh air damper
- 4 Weather protection
- 5 Unit control box
- 6 Fan
- 7 Extract air filter
- 8 Recirculation damper
- 9 Fan access door
- 10 Frost controller
- 11 Hydraulic connection coil access door
- 12 Heating/cooling coil
- 13 Condensate separator
- 14 Hydraulic assembly throttling circuit
- 15 Condensate drain

Fig. 10: TopVent® SC construction

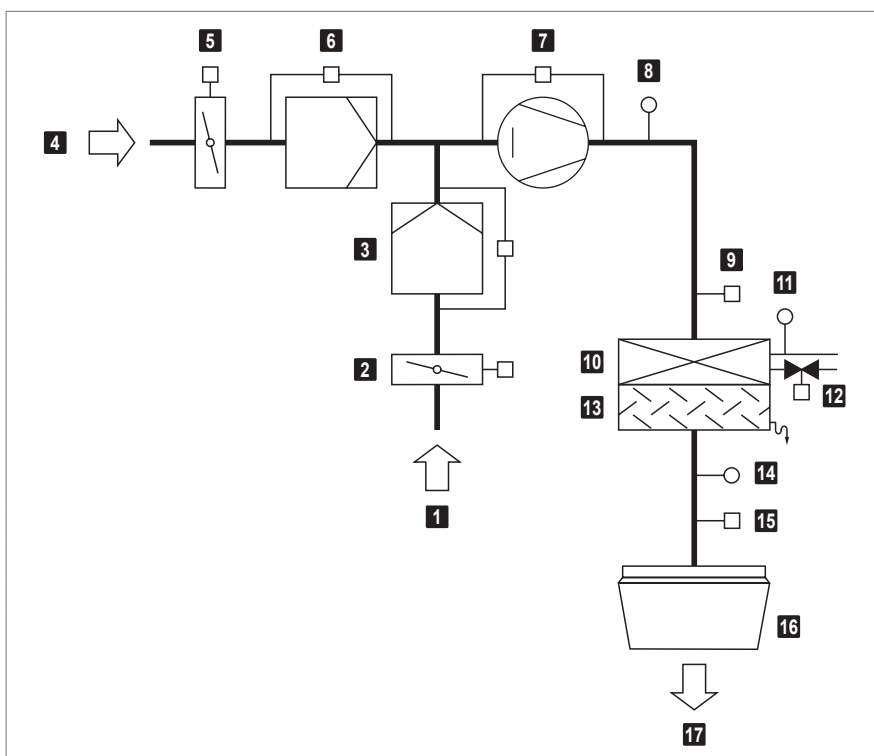

- 1 Extract air
- 2 Recirculation damper with actuator
- 3 Extract air filter with differential pressure switch
- 4 Fresh air
- 5 Fresh air damper with actuator
- 6 Fresh air filter with differential pressure switch
- 7 Fan with flow rate monitoring
- 8 Mixed air temperature sensor
- 9 Frost controller
- 10 Heating/cooling coil
- 11 Return temperature sensor
- 12 Control valve with actuator (option)
- 13 Condensate separator
- 14 Supply air temperature sensor
- 15 Actuator Air-Injector
- 16 Air-Injector
- 17 Supply air

Fig. 11: TopVent® SC function diagram

3.7 TopVent® SHC

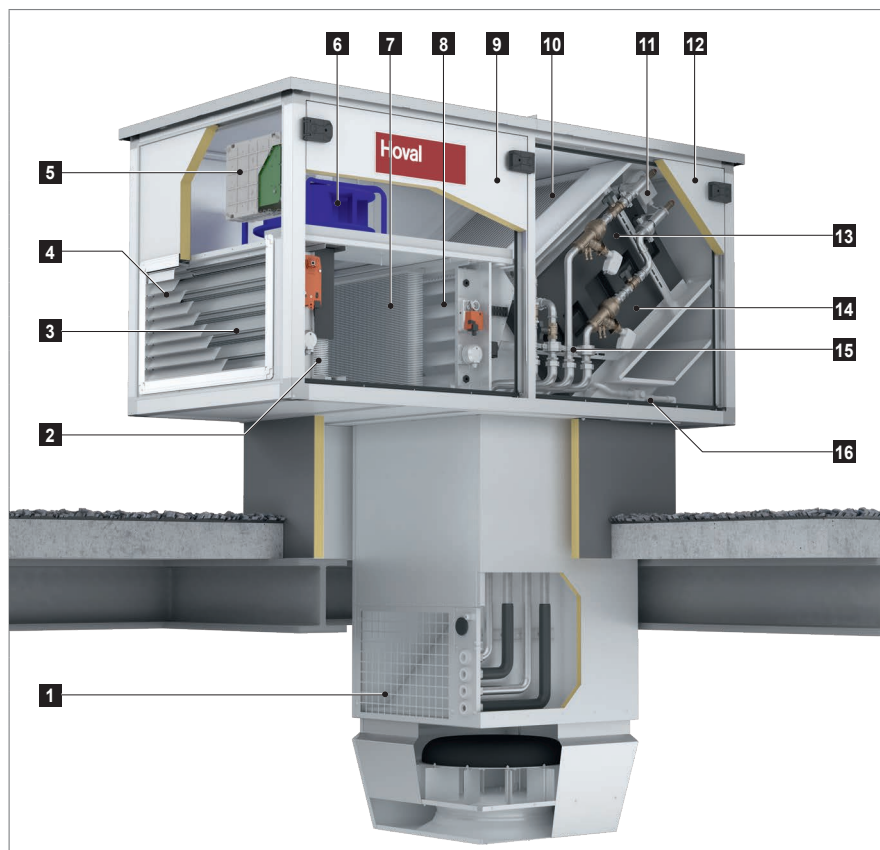

- 1 Extract air grille
- 2 Fresh air filter
- 3 Fresh air damper
- 4 Weather protection
- 5 Unit control box
- 6 Fan
- 7 Extract air filter
- 8 Recirculation damper
- 9 Fan access door
- 10 Heating coil
- 11 Frost controller
- 12 Hydraulic connection access door
- 13 Cooling coil
- 14 Condensate separator
- 15 Hydraulic assembly throttling circuit
- 16 Condensate drain

Fig. 12: TopVent® SHC construction

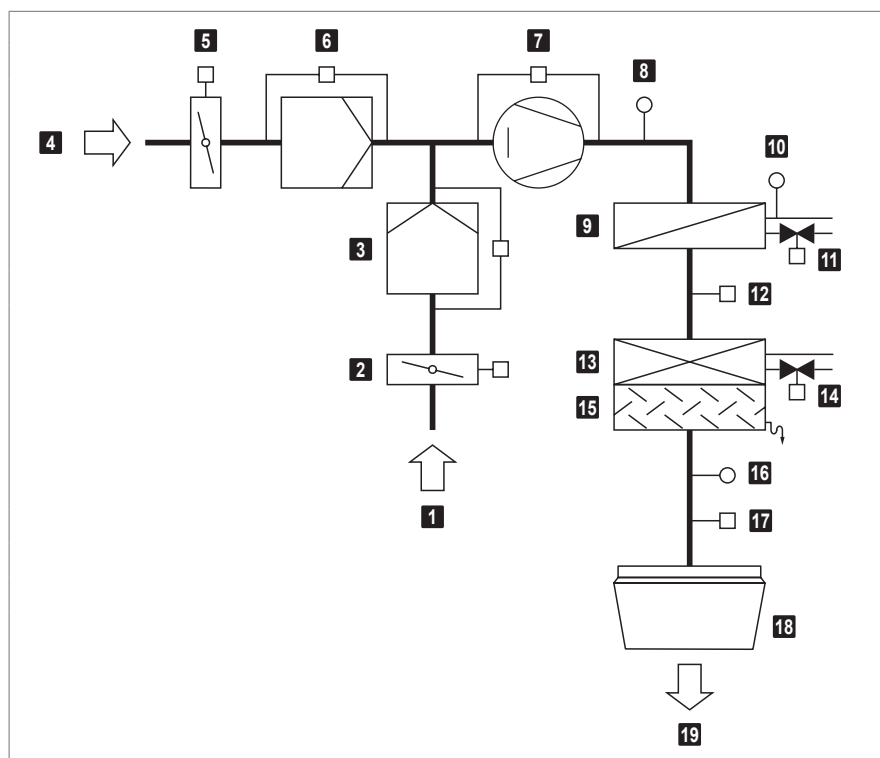

- 1 Extract air
- 2 Recirculation damper with actuator
- 3 Extract air filter with differential pressure switch
- 4 Fresh air
- 5 Fresh air damper with actuator
- 6 Fresh air filter with differential pressure switch
- 7 Fan with flow rate monitoring
- 8 Mixed air temperature sensor
- 9 Heating coil
- 10 Return temperature sensor
- 11 Control valve with actuator (option)
- 12 Frost controller
- 13 Cooling coil
- 14 Control valve with actuator (option)
- 15 Condensate separator
- 16 Supply air temperature sensor
- 17 Actuator Air-Injector
- 18 Air-Injector
- 19 Supply air

Fig. 13: TopVent® SHC function diagram



## 4 Operating modes

The units have the following operating modes:

- Supply air speed 2 (only TopVent® SH, SC, SHC)
- Supply air speed 1 (only TopVent® SH, SC, SHC)
- Recirculation
- Recirculation speed 1
- Standby

The TopTronic® C control system regulates these operating modes automatically for each control zone in accordance with the specifications in the calendar. The following points also apply:

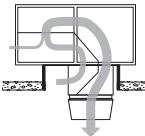
- The operating mode of a control zone can be switched over manually.
- Each TopVent® unit can operate individually in a local operating mode: Off, Supply air speed 2, Supply air speed 1, Recirculation, Recirculation speed 1 (depending on the unit type)

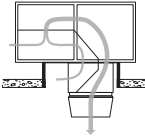
Code	Operating mode		Description
SA2	<b>Supply air speed 2</b> The fan runs at speed 2 (high air flow rate). The room temperature set value day is active. The unit blows fresh air into the room. The control of the fresh air ratio can be selected:		
	<u>Fixed fresh air ratio:</u> The unit operates continuously with the set fresh air ratio. The system controls the heating/cooling according to the heating/cooling demand.		Fan ..... speed 2 Fresh air damper ..... 10 % open <sup>1)</sup> Heating/cooling ..... 0-100 % <sup>2)</sup>  <sup>1)</sup> Percentage is adjustable <sup>2)</sup> Depending on heat or cool demand
	<u>Variable fresh air ratio:</u> <ul style="list-style-type: none"> <li>■ The system regulates the fresh air ratio depending on the temperature. The set fresh air ratio serves as a minimum value. If the temperature conditions permit, more fresh air is brought into the room and used for free heating or free cooling. Only when this potential is fully utilised is the heating/cooling switched on via the coil if required.</li> <li>■ If a combination sensor for room air is installed (option), the system additionally controls the fresh air ratio depending on the air quality.                             <ul style="list-style-type: none"> <li>– If there is no heat demand, the fresh air damper is opened 100% if the indoor air quality is too poor.</li> <li>– When the setpoint value for the CO<sub>2</sub> or VOC content of the room air is reached, the fresh air damper closes again to the set minimum value.</li> </ul> </li> </ul>		Fan ..... speed 2 Fresh air damper ..... MIN-100 % open <sup>1)</sup> Heating/cooling ..... 0-100 % <sup>2)</sup>  <sup>1)</sup> A minimum value can be set <sup>2)</sup> Depending on heat or cool demand
 <b>Notice</b> In order to save heating energy, the unit only operates with the set minimum fresh air rate when heat is required.			
SA1	<b>Supply air speed 1</b> The same as SA2, but the fan operates at speed 1 (low air flow rate)		Fan ..... speed 1 Fresh air damper ..... MIN-100 % open <sup>1)</sup> Heating/cooling ..... 0-100 %  <sup>1)</sup> Fixed or variable (see above)

Code	Operating mode		Description
REC	<b>Recirculation</b> On/Off operation: during heat or cool demand, the unit draws in room air, heats or cools it and blows it back into the room. The room temperature set value day is active.		Fan ..... Speed 1 / 2 <sup>1)</sup> Fresh air damper..... closed Heating/cooling ..... on <sup>1)</sup>  <sup>1)</sup> Depending on heat or cool demand
DES	■ <b>De-stratification:</b> To avoid heat build-up under the ceiling, it may be appropriate to switch on the fan when there is no heat demand (either in permanent operation or in on/off operation depending on the temperature stratification, as desired).		Fan ..... speed 2 Fresh air damper..... closed Heating/cooling ..... off
REC1	<b>Recirculation speed 1</b> The same as REC, but the unit operates only at speed 1 (low air flow rate)		Fan ..... speed 1 Fresh air damper..... closed Heating/cooling ..... on <sup>1)</sup>  <sup>1)</sup> Depending on heat or cool demand
DES	■ <b>De-stratification:</b> The same as for REC, but the unit operates only at speed 1		Fan ..... speed 1 Fresh air damper..... closed Heating/cooling ..... off
ST	<b>Standby</b> The unit is ready for operation. The following operating modes are activated if required:		
CPR	■ <b>Cooling protection:</b> If the room temperature drops below the set value for cooling protection, the unit heats up the room in recirculation operation.		Fan ..... speed 2 Fresh air damper..... closed Heating ..... on
OPR	■ <b>Overheating protection: (only cooling units)</b> If the room temperature rises above the set value for overheating protection, the unit cools down the room in recirculation operation.		Fan ..... speed 2 Fresh air damper..... closed Cooling..... on
NCS	■ <b>Night cooling: (only TopVent® SH, SC, SHC supply air units)</b> If the room temperature exceeds the set value for night cooling and the current fresh air temperature permits it, the unit blows cool fresh air into the room and extracts warmer room air.		Fan ..... speed 2 Fresh air damper..... open Heating/cooling ..... off
L_OFF	<b>Off (local operating mode)</b> The unit is switched off. Frost protection for the unit remains active.		Fan ..... off Fresh air damper..... closed Heating/cooling ..... off
-	<b>Forced heating (only TopVent® SH, SC, SHC supply air units)</b> The unit draws in room air, warms it and blows it back into the room. Forced heating can be activated and set as required by the Hoval service technician. For example, it is suitable for heating the hall before taking the control system into operation or if the controller fails during the heating period.		Fan ..... speed 2 <sup>1)</sup> Fresh air damper..... closed <sup>1)</sup> Heating ..... on <sup>1)</sup>  <sup>1)</sup> Adjustable by the Hoval service technician

Table 1: Operating modes

## 5 Type code

### TopVent® CH, CC, CHC recirculation units

Availability		CHC - 9 B C / ST . V1 . D1 / -- . CA . Z / V . -- / TC . PP . --	
<b>Unit type</b>			
CH	•	CH	Recirculation unit with heating section
CC	•	CC	Recirculation unit with heating/cooling section
CHC	•	CHC	Recirculation unit with heating and cooling section
<b>Unit size</b>			
•	•	6	Size 6
•	•	9	Size 9
<b>Heating section</b>			
•	•	-	without heating section
•	•	A	with coil type A
•	•	B	with coil type B
•	•	C	with coil type C
<b>Heating/cooling section</b>			
•	•	-	without heating/cooling section
•	•	C	with coil type C
•	•	D	with coil type D
<b>Design</b>			
•	•	ST	Standard
<b>Connection module</b>			
•	•	V1	Standard
•	•	V2	Length + 450 mm
•	•	V3	Length + 900 mm
<b>Air outlet</b>			
•	•	D1	Design with Air-Injector
•	•	D0	Design without Air-Injector
•	•	DB	Air distribution box
•	•	DN	Outlet nozzle
<b>Reserve</b>			
<b>Surface</b>			
•	•	--	Standard
•	•	CA	Coating of roof unit (anthracite grey)
•	•	LU	Paint finish of below-roof unit (as desired)
•	•	CL	Coating of roof unit and paint finish of below-roof unit

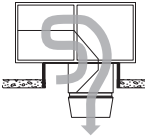
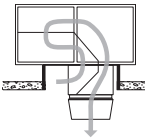
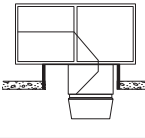
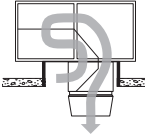
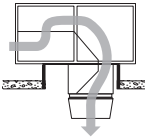
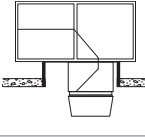
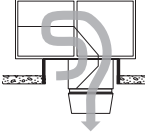
Availability			CHC - 9 B C / ST . V1 . D1 / -- . CA . Z / V . -- / TC . PP . --		
CH	CC	CHC			
			<b>Silencer</b>		
•	•	•	-	without	
•	•	•	Z	Supply air silencer	
			<b>Hydraulics</b>		
•	•	•	-	without	
•	•	•	V	Hydraulic assembly throttling circuit	
			<b>Reserve</b>		
			<b>Control system</b>		
•	•	•	TC	TopTronic® C	
•	•		KK	Terminal box design	
			<b>Pump control</b>		
•	•	•	--	without	
•	•	•	PH	Heating pump	
	•	•	PK	Heating or cooling pump	
	•	•	PP	Heating pump and cooling pump	
			<b>Reserve</b>		

Table 2: Type code for recirculation units

TopVent® SH, SC, SHC supply air units

Availability		SHC - 9 B C / ST . V1 . D1 / -- . CA . Z / V . -- / TC . PP . --	
		<b>Unit type</b>	
SH	SH	SH	Supply air unit with heating section
SC	SC	SC	Supply air unit with heating/cooling section
SHC	SHC	SHC	Supply air unit with heating and cooling section
		<b>Unit size</b>	
•	•	•	6 Size 6
•	•	•	9 Size 9
		<b>Heating section</b>	
	•	-	without heating section
•	•	A	with coil type A
•	•	B	with coil type B
•	•	C	with coil type C
		<b>Heating/cooling section</b>	
•		-	without heating/cooling section
•	•	C	with coil type C
•	•	D	with coil type D
		<b>Design</b>	
•	•	•	ST Standard
		<b>Connection module</b>	
•	•	•	V1 Standard
•	•	•	V2 Length + 450 mm
•	•	•	V3 Length + 900 mm
		<b>Air outlet</b>	
•	•	•	D1 Design with Air-Injector
•	•	•	D0 Design without Air-Injector
•	•	•	DB Air distribution box
		<b>Reserve</b>	
		<b>Surface</b>	
•	•	•	-- Standard
•	•	•	CA Coating of roof unit (anthracite grey)
•	•	•	LU Paint finish of below-roof unit (as desired)
•	•	•	CL Coating of roof unit and paint finish of below-roof unit



Availability			SHC - 9 B C / ST . V1 . D1 / -- . CA . Z / V . -- / TC . PP . --		
SH	SC	SHC			
<b>Silencer</b>					
•	•	•	-	without	
•	•	•	Z	Supply air silencer	
<b>Hydraulics</b>					
•	•	•	-	without	
•	•	•	V	Hydraulic assembly throttling circuit	
<b>Reserve</b>					
<b>Control system</b>					
•	•	•	TC	TopTronic® C	
<b>Pump control</b>					
•	•	•	--	without	
•	•	•	PH	Heating pump	
•	•	•	PK	Heating or cooling pump	
•	•	•	PP	Heating pump and cooling pump	
<b>Reserve</b>					

Table 3: Type code for supply air units

## 6 Technical data

### 6.1 Application limits

Extract air temperature	max.	°C	45	
Moisture content of extract air	max.	g/kg	15	
Fresh air temperature	min.	°C	-20	
	max.	°C	45	
Supply air temperature	max.	°C	60	
Temperature of the heating medium	max.	°C	90	
Pressure of the heating/cooling medium	max.	kPa	800	
Air flow rate	Size 6:	min.	m³/h	3100
	Size 9:	min.	m³/h	5000
Condensate quantity	Size 6:	max.	kg/h	90
	Size 9:	max.	kg/h	150
The units cannot be used in:				
<ul style="list-style-type: none"> <li>■ Damp locations</li> <li>■ Places with a corrosive or aggressive environment</li> <li>■ Spaces with a large amount of dust</li> <li>■ Areas where there is danger of explosion</li> </ul>				

Table 4: Application limits

### 6.2 Electrical connection

Unit type		CH, CC, SH, SC		CHC, SHC	
Unit size		6	9	6	9
Supply voltage	V AC	3 x 400	3 x 400	3 x 400	3 x 400
Permitted voltage tolerance	%	± 5	± 5	± 5	± 5
Frequency	Hz	50	50	50	50
Connected load	kW	2.23	3.33	2.43	3.53
Current consumption max.	A	4.17	5.87	4.17	5.87
Series fuse	A	13	13	13	13
Protection rating	-	IP 54	IP 54	IP 54	IP 54

Table 5: Electrical connection

### 6.3 Air flow rate

Unit size		6	9
Nominal air flow rate	m³/h	6000	9000
Floor area covered	m²	537	946

Table 6: Air flow rate

### 6.4 Air filtration

Filter	Fresh air <sup>1)</sup>	Extract air
Class acc. to ISO 16890	ISO ePM <sub>1</sub> 55 %	ISO ePM <sub>1</sub> 55 %
Class acc. to EN 779	F7	F7
Factory setting of differential pressure switches	300 Pa	300 Pa

<sup>1)</sup> only TopVent® SH, SC, SHC supply air units

Table 7: Air filtration

6.5 Heat output

TopVent® CH, CC, CHC recirculation units

Unit size	Coil type	Heating capacity P <sub>rated,h</sub> (in kW)
6	A	13.2
	B	18.9
	C	29.8
9	A	22.6
	B	28.5
	C	46.2
	D	54.2
Reference:	Standard rating conditions for fan coil units acc. to Commission Regulation (EU) 2016/2281 <ul style="list-style-type: none"> <li>■ Room air temperature .....20 °C</li> <li>■ Extract air temperature .....22 °C</li> <li>■ Heating medium temperature.....45/40 °C</li> <li>■ Nominal air flow rate</li> </ul>	

Table 8: TopVent® CH, CC, CHC heat output

TopVent® SH, SC, SHC supply air units

Unit size	Coil type	Heating capacity P <sub>rated,h</sub> (in kW)
6	A	13.2
	B	18.9
	C	29.8
9	A	22.6
	B	28.5
	C	46.2
	D	54.2
Reference:	<ul style="list-style-type: none"> <li>■ Room air temperature .....20 °C</li> <li>■ Extract air temperature .....22 °C</li> <li>■ Fresh air temperature .....12 °C</li> <li>■ Heating medium temperature.....45/40 °C</li> <li>■ Nominal air flow rate</li> <li>■ Fresh air ratio .....10%</li> </ul>	

Table 9: TopVent® SH, SC, SHC heat output

6.6 Cooling capacity

TopVent® CC, CHC recirculation units

Unit size	Coil type	Cooling capacity (sensible) P <sub>rated,c</sub> (in kW)	Cooling capacity (latent) P <sub>rated,c</sub> (in kW)
6	C	26.5	5.6
9	C	41.0	7.3
	D	48.6	15.2
Reference:	Standard rating conditions for fan coil units according to Commission Regulation (EU) 2016/2281 <ul style="list-style-type: none"> <li>■ Room air temperature .....27 °C (dry bulb) 19 °C (wet bulb)</li> <li>■ Room air humidity .....46.26 % rH</li> <li>■ Extract air temperature .....29 °C</li> <li>■ Cooling medium temperature.....7/12 °C</li> <li>■ Nominal air flow rate</li> </ul>		

Table 10: TopVent® CC, CHC cooling capacity

TopVent® SC, SHC supply air units

Unit size	Coil type	Cooling capacity (sensible) P <sub>rated,c</sub> (in kW)	Cooling capacity (latent) P <sub>rated,c</sub> (in kW)
6	C	26.5	5.6
9	C	41.0	7.3
	D	48.6	15.2
Reference:	<ul style="list-style-type: none"> <li>■ Room air temperature .....27 °C (dry bulb) 19 °C (wet bulb)</li> <li>■ Room air humidity .....46.26 % rH</li> <li>■ Extract air temperature .....29 °C</li> <li>■ Fresh air temperature .....32 °C</li> <li>■ Cooling medium temperature.....7/12 °C</li> <li>■ Nominal air flow rate</li> <li>■ Fresh air ratio .....10%</li> </ul>		

Table 11: TopVent® SC, SHC cooling capacity

6.7 Dimensions and weights

TopVent® CH

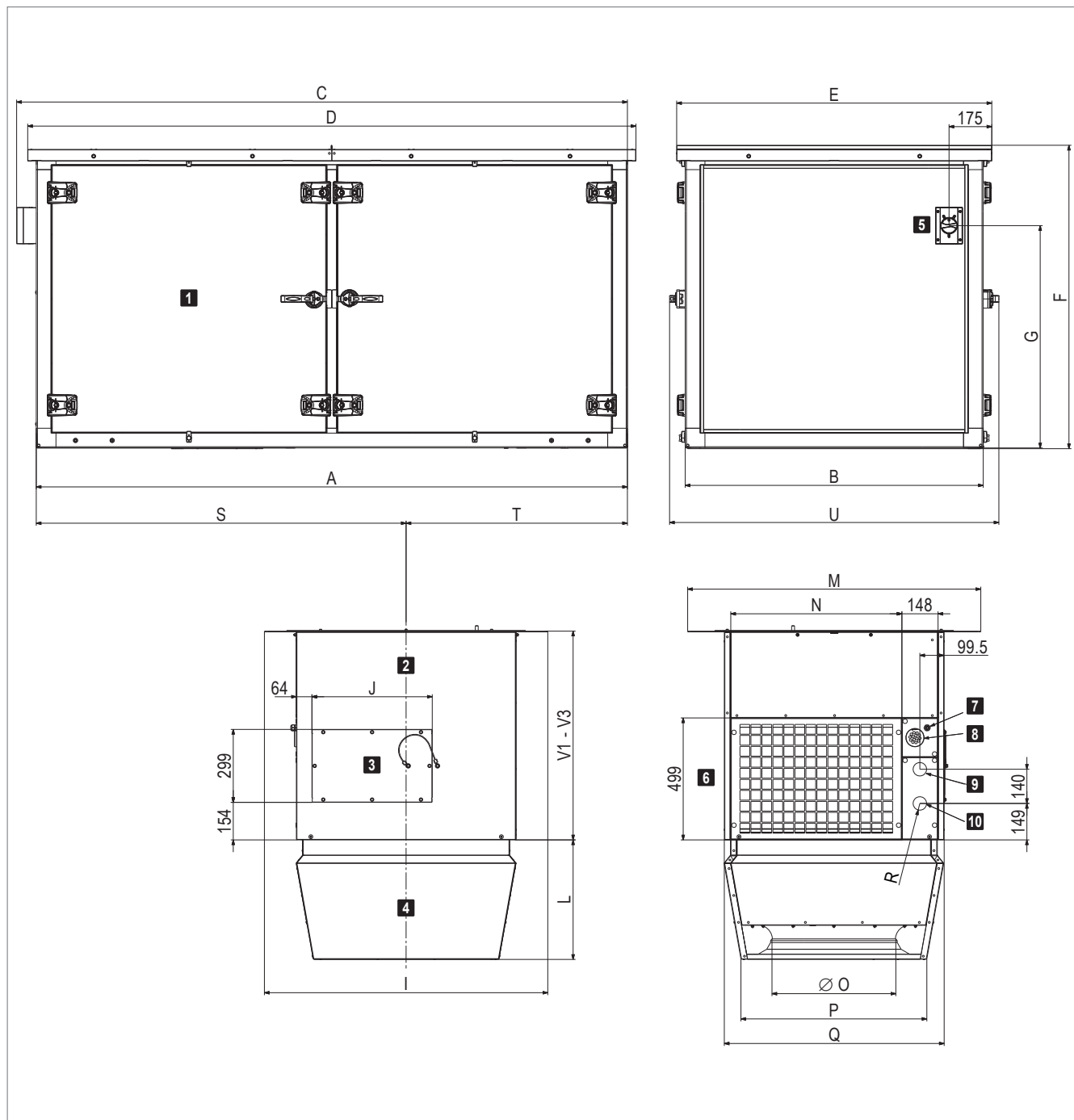

- |                            |  |
|----------------------------|--|
| <b>1</b> Roof unit         | <b>6</b> Extract air grille                  |
| <b>2</b> Connection module | <b>7</b> Cable gland for power supply        |
| <b>3</b> Installation lid  | <b>8</b> Cable feedthrough for signal cables |
| <b>4</b> Air-Injector      | <b>9</b> Heating circuit return              |
| <b>5</b> Isolation switch  | <b>10</b> Heating circuit flow               |

Fig. 14: Dimensional drawing for TopVent® CH with hydraulic assembly throttling circuit (dimensions in mm)

Unit type		CH-6	CH-9
A	mm	2420	2725
B	mm	1220	1420
C	mm	2500	2805
D	mm	2490	2795
E	mm	1290	1490
F	mm	1239	1439
G	mm	910	1010
I	mm	1160	1360
J	mm	492	492
L	mm	490	570
M	mm	1200	1400
N	mm	701	901
Ø O	mm	500	630
P	mm	767	937
Q	mm	900	1100
R (internal thread) <sup>1)</sup>	"	G 1½	G 1½
S	mm	1514	1684
T	mm	906	1041
U	mm	1348	1548
V1	mm	850	850
V2	mm	1300	1300
V3	mm	1750	1750

<sup>1)</sup> TopVent® units without hydraulic assembly: pipe outlets Ø 55 mm

Table 12: TopVent® CH dimensions

Unit type	CH-	6 A	6B	6C	9 A	9B	9C
<b>Total</b>	<b>kg</b>	<b>610</b>	<b>609</b>	<b>616</b>	<b>779</b>	<b>778</b>	<b>791</b>
Roof unit	kg	468	467	474	597	596	609
Below-roof unit	kg	142	142	142	182	182	182
Air-Injector	kg	40	40	40	57	57	57
Connection module V1	kg	102			125		
Additional weight V2	kg	+ 42			+ 50		
Additional weight V3	kg	+ 85			+ 101		

Table 13: TopVent® CH weights

Heating section		6 A	6B	6C	9 A	9B	9C
Connection (internal thread)	"	Rp 1¼	Rp 1¼	Rp 1¼	Rp 1½	Rp 1½	Rp 1½
Water content of the coil	l	4.6	4.6	7.9	7.4	7.4	12.4

Table 14: Hydraulic connection of the heating section in the roof unit (without hydraulic assembly throttling circuit)

TopVent® CC

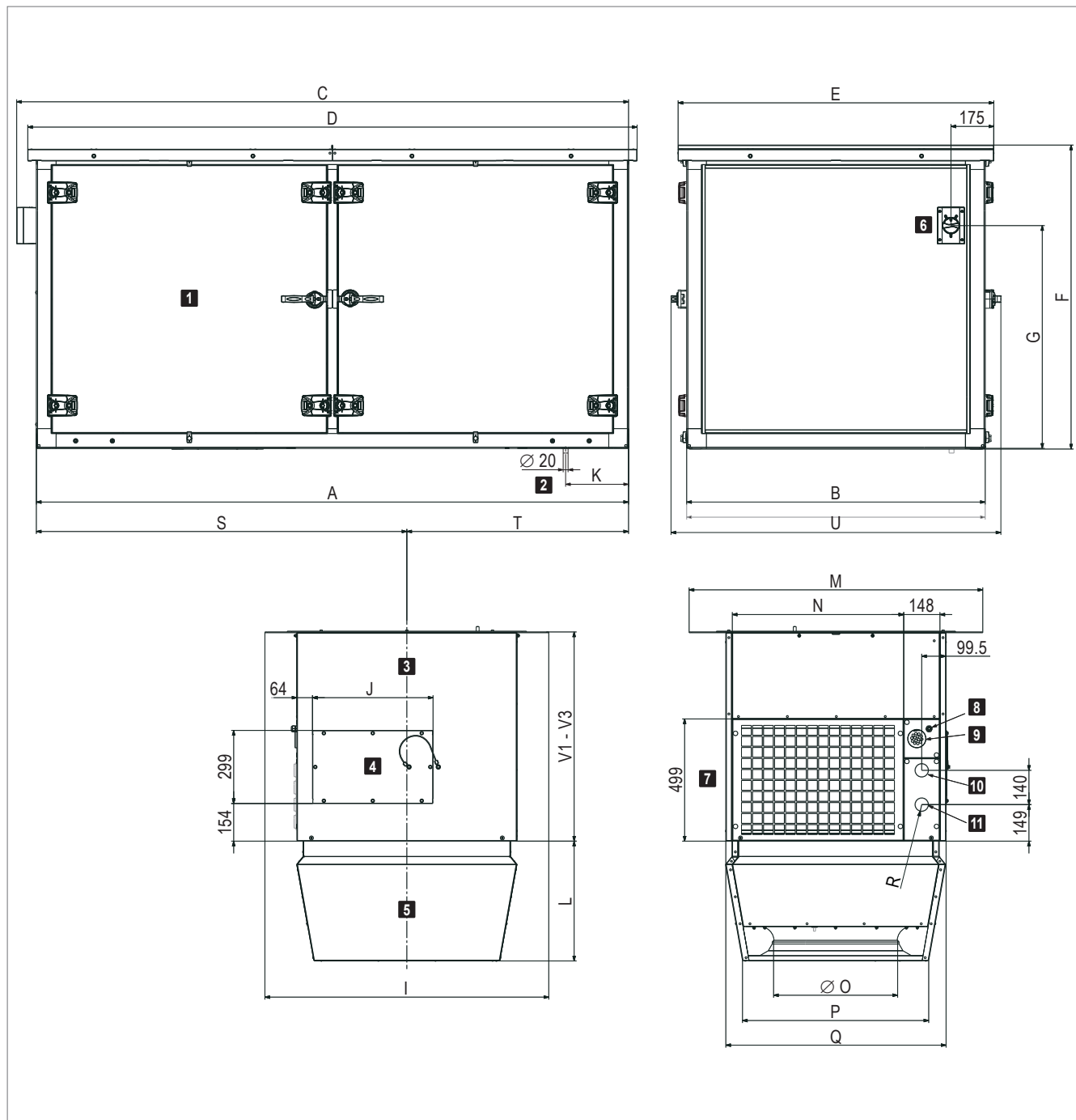

- |                            |  |
|----------------------------|--|
| <b>1</b> Roof unit         | <b>7</b> Extract air grille                  |
| <b>2</b> Condensate drain  | <b>8</b> Cable gland for power supply        |
| <b>3</b> Connection module | <b>9</b> Cable feedthrough for signal cables |
| <b>4</b> Installation lid  | <b>10</b> Heating/cooling circuit return     |
| <b>5</b> Air-Injector      | <b>11</b> Heating/cooling circuit flow       |
| <b>6</b> Isolation switch  |  |

Fig. 15: Dimensional drawing for TopVent® CC with hydraulic assembly throttling circuit (dimensions in mm)

Unit type		CC-6	CC-9
A	mm	2420	2725
B	mm	1220	1420
C	mm	2500	2805
D	mm	2490	2795
E	mm	1290	1490
F	mm	1239	1439
G	mm	910	1010
I	mm	1160	1360
J	mm	492	492
K	mm	257	292
L	mm	490	570
M	mm	1200	1400
N	mm	701	901
Ø O	mm	500	630
P	mm	767	937
Q	mm	900	1100
R (internal thread) <sup>1)</sup>	"	G 1½	G 1½
S	mm	1514	1684
T	mm	906	1041
U	mm	1348	1548
V1	mm	850	850
V2	mm	1300	1300
V3	mm	1750	1750

<sup>1)</sup> TopVent® units without hydraulic assembly: pipe outlets Ø 55 mm

Table 15: TopVent® CC dimensions

Unit type	CC-	6-C	9-C	9-D
<b>Total</b>	<b>kg</b>	<b>647</b>	<b>824</b>	<b>843</b>
Roof unit	kg	505	642	661
Below-roof unit	kg	142	182	182
Air-Injector	kg	40	57	57
Connection module V1	kg	102	125	
Additional weight V2	kg	+ 42	+ 50	
Additional weight V3	kg	+ 85	+ 101	

Table 16: TopVent® CC weights

Heating/cooling section		6-C	9-C	9-D
Connection (internal thread)	"	Rp 1¼	Rp 1½	Rp 2
Water content of the coil	l	7.9	12.4	19.2

Table 17: Hydraulic connection of the heating/cooling section in the roof unit (without hydraulic assembly throttling circuit)

TopVent® CHC

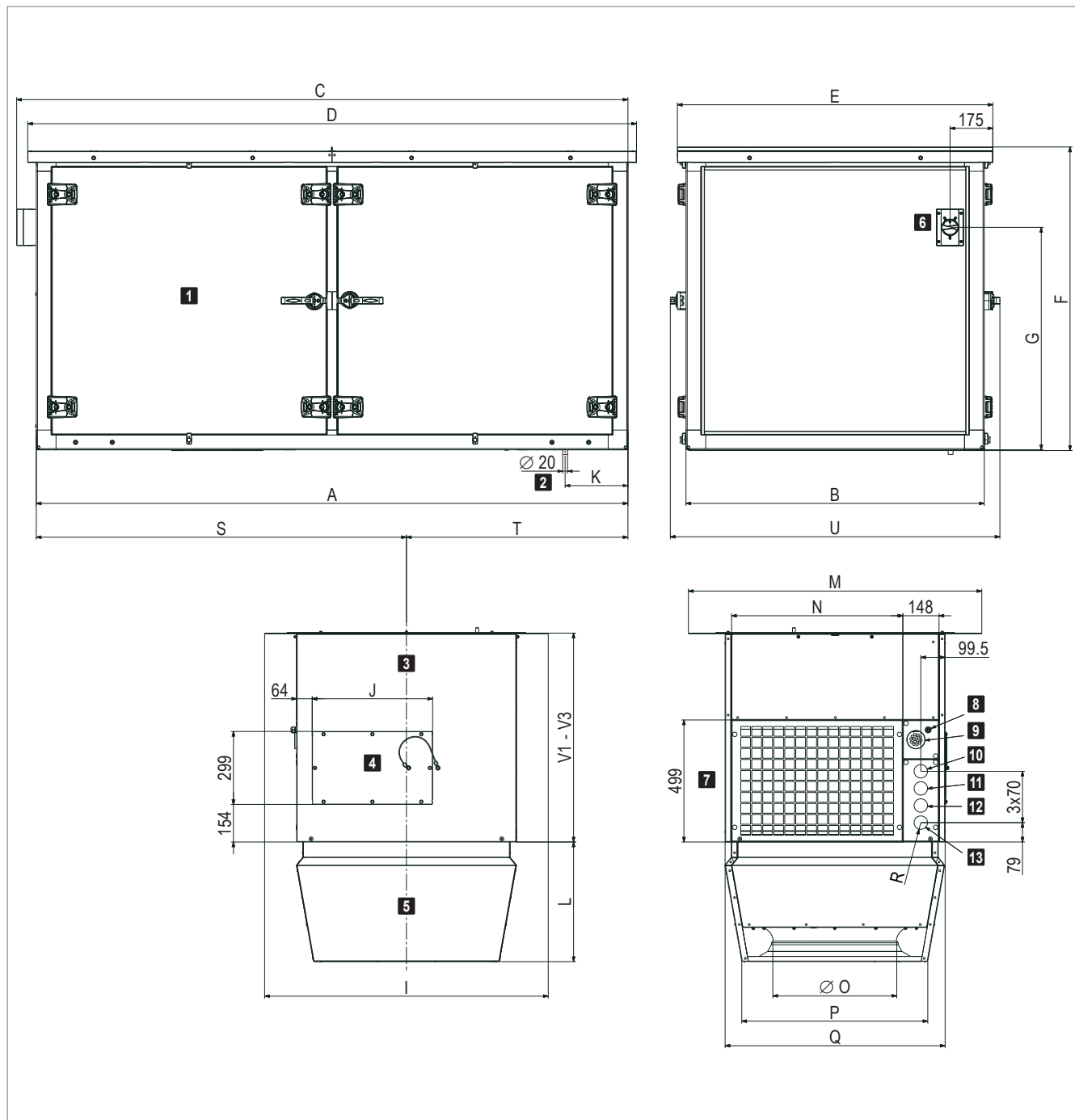

- |                             |  |
|-----------------------------|--|
| <b>1</b> Roof unit          | <b>8</b> Cable gland for power supply        |
| <b>2</b> Condensate drain   | <b>9</b> Cable feedthrough for signal cables |
| <b>3</b> Connection module  | <b>10</b> Heating circuit return             |
| <b>4</b> Installation lid   | <b>11</b> Cooling circuit return             |
| <b>5</b> Air-Injector       | <b>12</b> Heating circuit flow               |
| <b>6</b> Isolation switch   | <b>13</b> Cooling circuit flow               |
| <b>7</b> Extract air grille |  |

Fig. 16: Dimensional drawing for TopVent® CHC with hydraulic assembly throttling circuit (dimensions in mm)



Unit type		CHC-6	CHC-9
A	mm	2420	2725
B	mm	1220	1420
C	mm	2500	2805
D	mm	2490	2795
E	mm	1290	1490
F	mm	1239	1439
G	mm	910	1010
I	mm	1160	1360
J	mm	492	492
K	mm	257	292
L	mm	490	570
M	mm	1200	1400
N	mm	701	901
Ø O	mm	500	630
P	mm	767	937
Q	mm	900	1100
R (internal thread) <sup>1)</sup>	"	G 1½	G 1½
S	mm	1514	1684
T	mm	906	1041
U	mm	1348	1548
V1	mm	850	850
V2	mm	1300	1300
V3	mm	1750	1750

<sup>1)</sup> TopVent® units without hydraulic assembly: pipe outlets Ø 55 mm

Table 18: TopVent® CHC dimensions

Unit type	CHC-	6AC	6BC	6CC	9AC	9BC	9CC	9AD	9BD	9CD
<b>Total</b>	<b>kg</b>	<b>678</b>	<b>677</b>	<b>684</b>	<b>867</b>	<b>866</b>	<b>879</b>	<b>886</b>	<b>885</b>	<b>898</b>
Roof unit	kg	536	535	542	685	684	697	704	703	716
Below-roof unit	kg	142	142	142	182	182	182	182	182	182
Air-Injector	kg	40	40	40	57	57	57	57	57	57
Connection module V1	kg	102			125					
Additional weight V2	kg	+ 42			+ 50					
Additional weight V3	kg	+ 85			+ 101					

Table 19: TopVent® CHC weights

Heating section		6 A	6B	6C	9 A	9B	9C
Connection (internal thread)	"	Rp 1¼	Rp 1¼	Rp 1¼	Rp 1½	Rp 1½	Rp 1½
Water content of the coil	l	4.6	4.6	7.9	7.4	7.4	12.4

Table 20: Hydraulic connection of the heating section in the roof unit (without hydraulic assembly throttling circuit)

Cooling section		6-C	9-C	9-D
Y (internal thread)	"	Rp 1¼	Rp 1½	Rp 2
Water content of the coil	l	7.9	12.4	19.2

Table 21: Hydraulic connection of the cooling section in the roof unit (without hydraulic assembly throttling circuit)

TopVent® SH

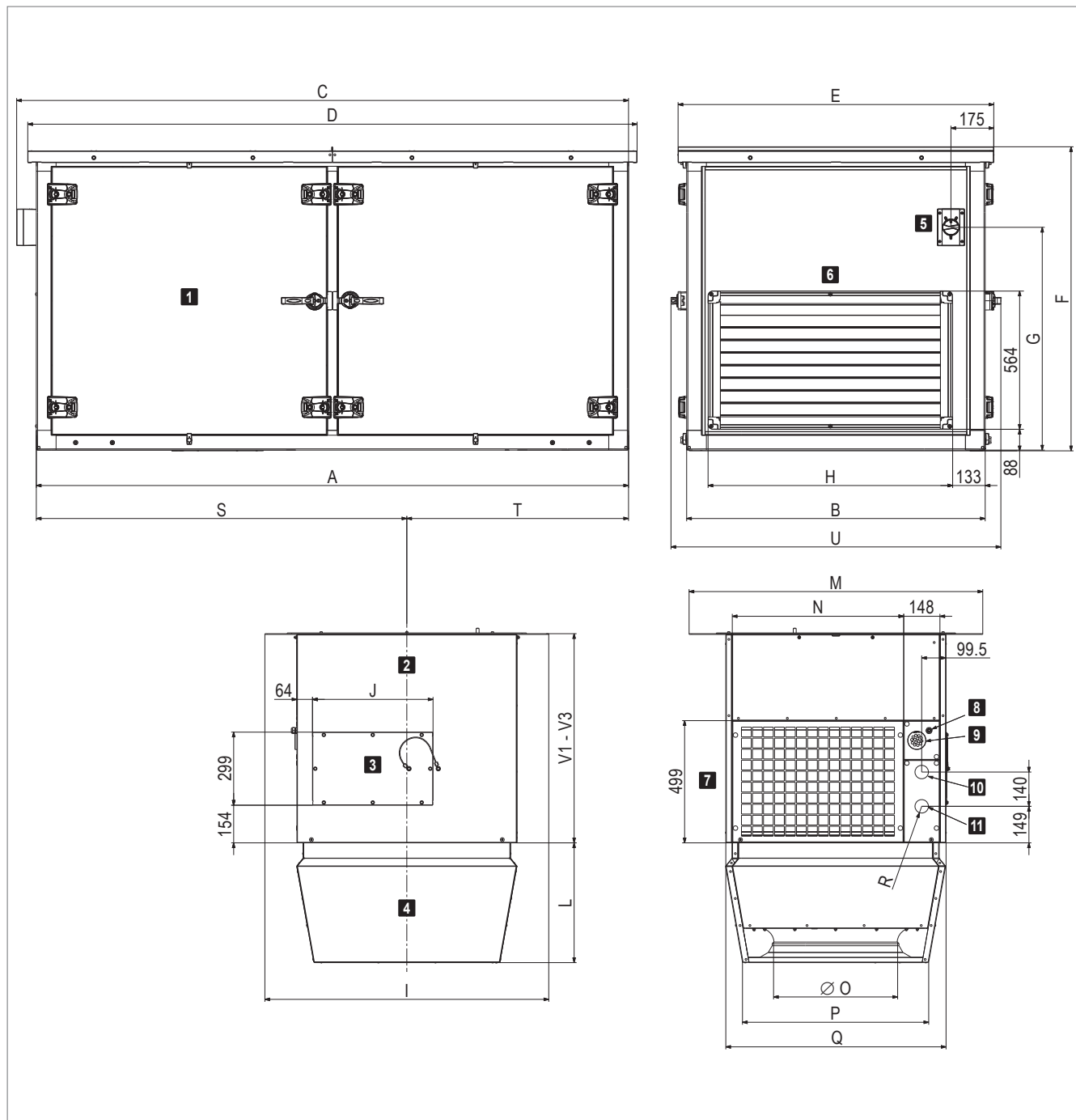

- |                             |  |
|-----------------------------|--|
| <b>1</b> Roof unit          | <b>7</b> Extract air grille                  |
| <b>2</b> Connection module  | <b>8</b> Cable gland for power supply        |
| <b>3</b> Installation lid   | <b>9</b> Cable feedthrough for signal cables |
| <b>4</b> Air-Injector       | <b>10</b> Heating circuit return             |
| <b>5</b> Isolation switch   | <b>11</b> Heating circuit flow               |
| <b>6</b> Weather protection |  |

Fig. 17: Dimensional drawing for TopVent® SH with hydraulic assembly throttling circuit (dimensions in mm)

Unit type		SH-6	SH-9
A	mm	2420	2725
B	mm	1220	1420
C	mm	2500	2805
D	mm	2490	2795
E	mm	1290	1490
F	mm	1239	1439
G	mm	910	1010
H	mm	999	1199
I	mm	1160	1360
J	mm	492	492
L	mm	490	570
M	mm	1200	1400
N	mm	701	901
Ø O	mm	500	630
P	mm	767	937
Q	mm	900	1100
R (internal thread) <sup>1)</sup>	"	G 1½	G 1½
S	mm	1514	1684
T	mm	906	1041
U	mm	1348	1548
V1	mm	850	850
V2	mm	1300	1300
V3	mm	1750	1750

<sup>1)</sup> TopVent® units without hydraulic assembly: pipe outlets Ø 55 mm

Table 22: TopVent® SH dimensions

Unit type	SH-	6 A	6B	6C	9 A	9B	9C
<b>Total</b>	<b>kg</b>	<b>655</b>	<b>654</b>	<b>661</b>	<b>834</b>	<b>833</b>	<b>846</b>
Roof unit	kg	513	512	519	652	651	664
Below-roof unit	kg	142	142	142	182	182	182
Air-Injector	kg	40	40	40	57	57	57
Connection module V1	kg	102			125		
Additional weight V2	kg	+ 42			+ 50		
Additional weight V3	kg	+ 85			+ 101		

Table 23: TopVent® SH weights

Heating section		6 A	6B	6C	9 A	9B	9C
Connection (internal thread)	"	Rp 1¼	Rp 1¼	Rp 1¼	Rp 1½	Rp 1½	Rp 1½
Water content of the coil	l	4.6	4.6	7.9	7.4	7.4	12.4

Table 24: Hydraulic connection of the heating section in the roof unit (without hydraulic assembly throttling circuit)

TopVent® SC

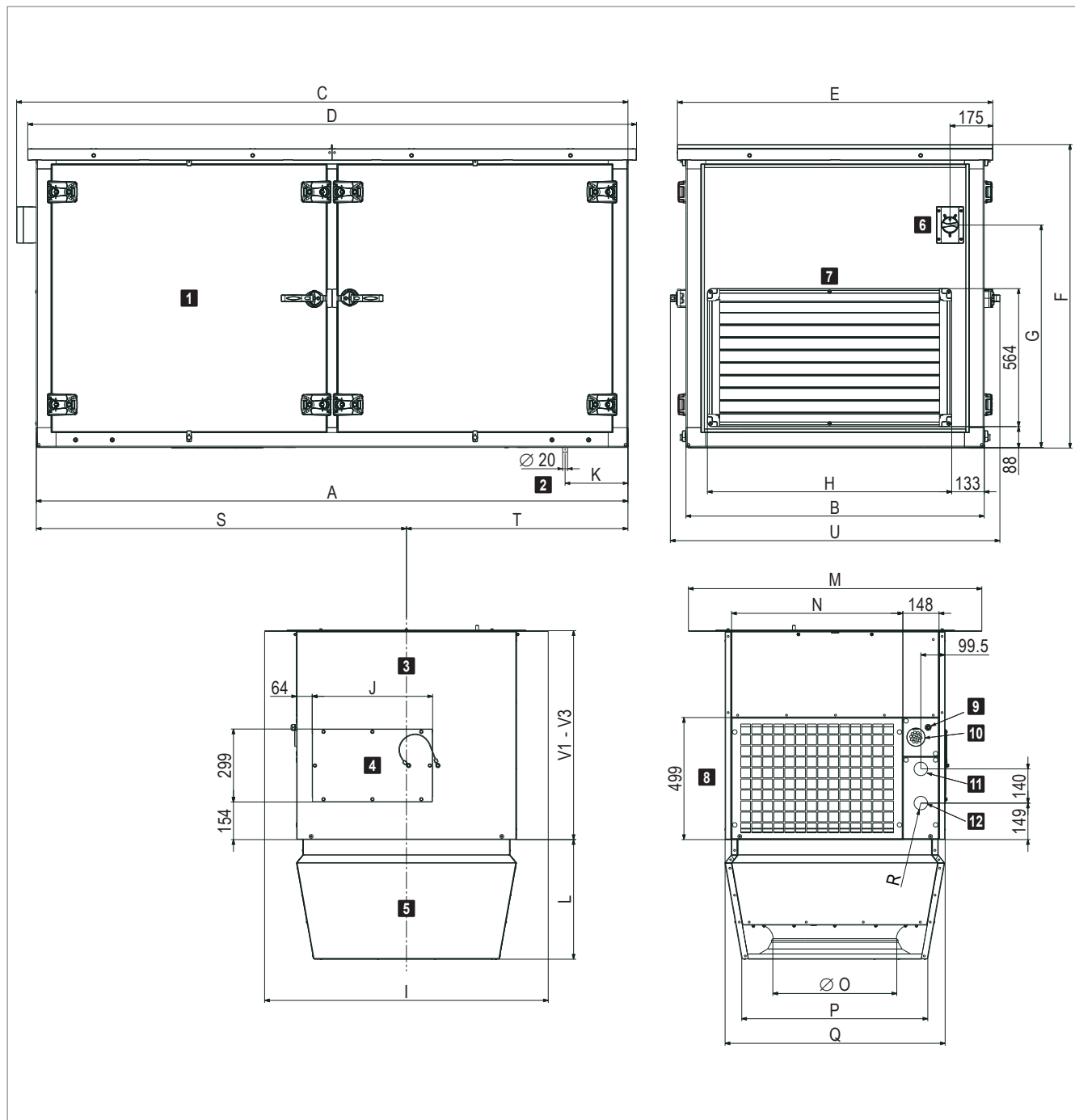

- |                            |   |
|----------------------------|---|
| <b>1</b> Roof unit         | <b>7</b> Weather protection                   |
| <b>2</b> Condensate drain  | <b>8</b> Extract air grille                   |
| <b>3</b> Connection module | <b>9</b> Cable gland for power supply         |
| <b>4</b> Installation lid  | <b>10</b> Cable feedthrough for signal cables |
| <b>5</b> Air-Injector      | <b>11</b> Heating/cooling circuit return      |
| <b>6</b> Isolation switch  | <b>12</b> Heating/cooling circuit flow        |

Fig. 18: Dimensional drawing for TopVent® SC with hydraulic assembly throttling circuit (dimensions in mm)

Unit type		SC-6	SC-9
A	mm	2420	2725
B	mm	1220	1420
C	mm	2500	2805
D	mm	2490	2795
E	mm	1290	1490
F	mm	1239	1439
G	mm	910	1010
H	mm	999	1199
I	mm	1160	1360
J	mm	492	492
K	mm	257	292
L	mm	490	570
M	mm	1200	1400
N	mm	701	901
Ø O	mm	500	630
P	mm	767	937
Q	mm	900	1100
R (internal thread) <sup>1)</sup>	"	G 1½	G 1½
S	mm	1514	1684
T	mm	906	1041
U	mm	1348	1548
V1	mm	850	850
V2	mm	1300	1300
V3	mm	1750	1750

<sup>1)</sup> TopVent® units without hydraulic assembly: pipe outlets Ø 55 mm

Table 25: TopVent® SC dimensions

Unit type	SC-	6-C	9-C	9-D
<b>Total</b>	<b>kg</b>	<b>692</b>	<b>879</b>	<b>898</b>
Roof unit	kg	550	697	716
Below-roof unit	kg	142	182	182
Air-Injector	kg	40	57	57
Connection module V1	kg	102	125	
Additional weight V2	kg	+ 42	+ 50	
Additional weight V3	kg	+ 85	+ 101	

Table 26: TopVent® SC weights

Heating/cooling section		6-C	9-C	9-D
Connection (internal thread)	"	Rp 1¼	Rp 1½	Rp 2
Water content of the coil	l	7.9	12.4	19.2

Table 27: Hydraulic connection of the heating/cooling section in the roof unit (without hydraulic assembly throttling circuit)

TopVent® SHC

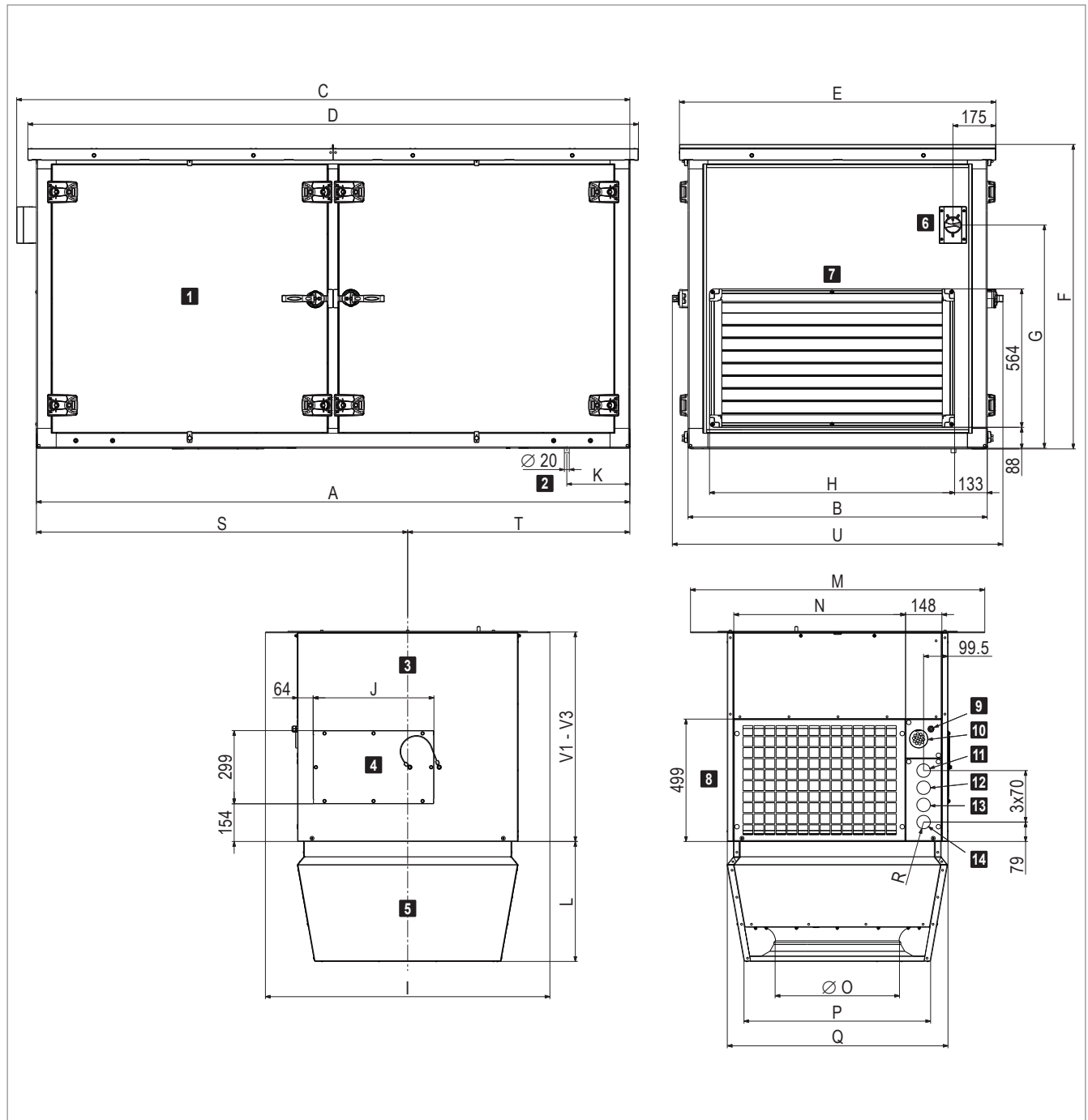

- |                             |   |
|-----------------------------|---|
| <b>1</b> Roof unit          | <b>8</b> Extract air grille                   |
| <b>2</b> Condensate drain   | <b>9</b> Cable gland for power supply         |
| <b>3</b> Connection module  | <b>10</b> Cable feedthrough for signal cables |
| <b>4</b> Installation lid   | <b>11</b> Heating circuit return              |
| <b>5</b> Air-Injector       | <b>12</b> Cooling circuit return              |
| <b>6</b> Isolation switch   | <b>13</b> Heating circuit flow                |
| <b>7</b> Weather protection | <b>14</b> Cooling circuit flow                |

Fig. 19: Dimensional drawing for TopVent® SHC with hydraulic assembly throttling circuit (dimensions in mm)

Unit type		SHC-6	SHC-9
A	mm	2420	2725
B	mm	1220	1420
C	mm	2500	2805
D	mm	2490	2795
E	mm	1290	1490
F	mm	1239	1439
G	mm	910	1010
H	mm	999	1199
I	mm	1160	1360
J	mm	492	492
K	mm	257	292
L	mm	490	570
M	mm	1200	1400
N	mm	701	901
Ø O	mm	500	630
P	mm	767	937
Q	mm	900	1100
R (internal thread) <sup>1)</sup>	"	G 1½	G 1½
S	mm	1514	1684
T	mm	906	1041
U	mm	1348	1548
V1	mm	850	850
V2	mm	1300	1300
V3	mm	1750	1750

<sup>1)</sup> TopVent® units without hydraulic assembly: pipe outlets Ø 55 mm

Table 28: TopVent® SHC dimensions

Unit type	SHC-	6AC	6BC	6CC	9AC	9BC	9CC	9AD	9BD	9CD
<b>Total</b>	<b>kg</b>	<b>723</b>	<b>722</b>	<b>729</b>	<b>922</b>	<b>921</b>	<b>934</b>	<b>941</b>	<b>940</b>	<b>953</b>
Roof unit	kg	581	580	587	740	739	752	759	758	771
Below-roof unit	kg	142	142	142	182	182	182	182	182	182
Air-Injector	kg	40	40	40	57	57	57	57	57	57
Connection module V1	kg	102			125					
Additional weight V2	kg	+ 42			+ 50					
Additional weight V3	kg	+ 85			+ 101					

Table 29: TopVent® SHC weights

Heating section		6 A	6B	6C	9 A	9B	9C
Connection (internal thread)	"	Rp 1¼	Rp 1¼	Rp 1¼	Rp 1½	Rp 1½	Rp 1½
Water content of the coil	l	4.6	4.6	7.9	7.4	7.4	12.4

Table 30: Hydraulic connection of the heating section in the roof unit (without hydraulic assembly throttling circuit)

Cooling section		6-C	9-C	9-D
Connection (internal thread)	"	Rp 1¼	Rp 1½	Rp 2
Water content of the coil	l	7.9	12.4	19.2

Table 31: Hydraulic connection of the cooling section in the roof unit (without hydraulic assembly throttling circuit)

6.8 Sound level

Unit type		CH-6C		CH-9C		CC-6-C		CC-9-C		CHC-6CC		CHC-9CC		
		indoors	outdoors	indoors	outdoors	indoors	outdoors	indoors	outdoors	indoors	outdoors	indoors	outdoors	
Sound pressure level (at a distance of 5 m) <sup>1)</sup>		dB(A)	55	42	58	45	55	42	59	46	55	43	59	47
Total sound power level		dB(A)	77	64	80	67	77	64	81	68	77	65	81	69
Octave sound power level	63 Hz	dB	45	40	46	41	45	40	47	42	45	41	47	43
	125 Hz	dB	61	55	64	58	61	55	65	59	58	54	60	56
	250 Hz	dB	67	57	69	59	67	57	70	60	67	59	70	62
	500 Hz	dB	71	60	73	62	71	60	73	62	71	61	73	63
	1000 Hz	dB	74	57	77	60	74	57	78	61	73	58	77	62
	2000 Hz	dB	70	56	75	61	70	56	76	62	69	57	75	63
	4000 Hz	dB	66	47	71	52	66	47	71	52	64	47	70	53
	8000 Hz	dB	65	39	65	39	65	39	66	40	63	39	65	41

<sup>1)</sup> with a hemispherical radiation pattern in a low-reflection room

Table 32: Sound level recirculation units

Unit type		SH-6C		SH-9C		SC-6-C		SC-9-C		SHC-6CC		SHC-9CC		
		indoors	outdoors <sup>1)</sup>	indoors	outdoors <sup>1)</sup>	indoors	outdoors <sup>1)</sup>	indoors	outdoors <sup>1)</sup>	indoors	outdoors <sup>1)</sup>	indoors	outdoors <sup>1)</sup>	
Sound pressure level (at a distance of 5 m) <sup>2)</sup>		dB(A)	55	47	58	49	55	47	59	50	55	48	59	50
Total sound power level		dB(A)	77	69	80	71	77	69	81	72	77	70	81	72
Octave sound power level	63 Hz	dB	45	44	46	44	45	44	47	45	45	45	47	46
	125 Hz	dB	61	56	64	57	61	55	65	58	58	55	60	55
	250 Hz	dB	67	63	69	63	67	63	70	64	67	64	70	65
	500 Hz	dB	71	65	73	65	71	65	73	66	71	66	73	67
	1000 Hz	dB	74	60	77	64	74	60	78	65	73	60	77	66
	2000 Hz	dB	70	58	75	64	70	59	76	65	69	59	75	66
	4000 Hz	dB	66	57	71	61	66	56	71	61	64	56	70	62
	8000 Hz	dB	65	57	65	57	65	57	66	57	63	57	65	58

<sup>1)</sup> with fresh air ratio 10 %

<sup>2)</sup> with a hemispherical radiation pattern in a low-reflection room

Table 33: Sound level supply air units



## 7 Options

### 7.1 Connection module

The connection module is available in 3 lengths for adapting the unit to local conditions. The connection module V3 is equipped with 2 installation lids.

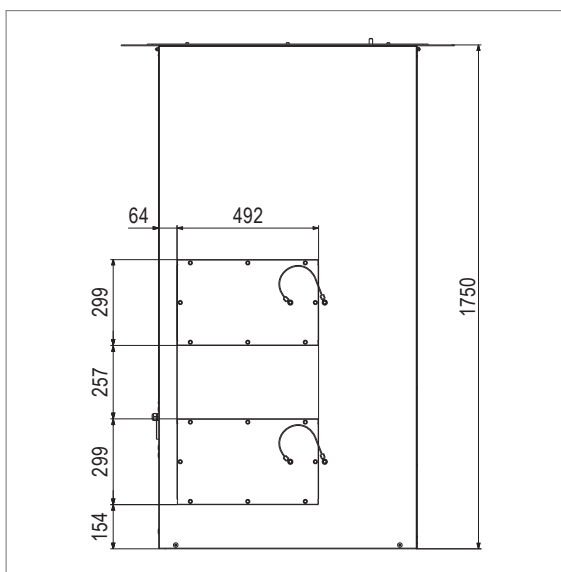

Fig. 20: Installation lids in connection module V3

### 7.2 Design without Air-Injector

TopVent® units in the design without Air-Injector are suitable for connecting to an air distribution system supplied by the client.

### 7.3 Air distribution box

For easy connection to ventilation ducts or fabric sleeves, TopVent® units are available with an air distribution box. This has a collar on 2 opposite sides as a connection piece to the on-site air distribution system.

The air distribution box replaces the Air-Injector.

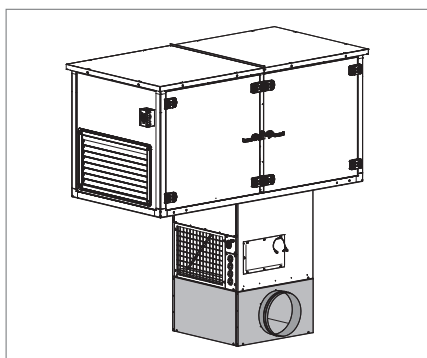

Fig. 21: TopVent® unit with air distribution box

#### 7.4 Outlet nozzle

The outlet nozzle replaces the Air-Injector. The external dimensions of the unit remain the same.

Size		6	9
Weight	kg	31	37

Fig. 22: Outlet nozzle weights

The air discharge angle cannot be adjusted. Units with outlet nozzle are well-suited for applications with lower comfort requirements and for large mounting heights (e.g. in high-bay warehouses).

#### 7.5 Coating of roof unit

The casing of the roof unit is made of coated zinc sheet (anthracite grey, similar to RAL 7016).

#### 7.6 Paint finish of below-roof unit

The below-roof unit is provided with an exterior painting in choice of RAL colour.

#### 7.7 Supply air silencer

The supply air silencer reduces noise emissions from TopVent® units. It consists of a sound-absorbing mat made of rock wool and is mounted above the fan on the casing ceiling. Weight: 20 kg.

#### 7.8 Hydraulic assembly throttling circuit

An assembly for the hydraulic throttling circuit is pre-installed in the unit. The assembly consists of the following components:

- Installed and wired in the roof unit, each for the heating and cooling circuit:
  - Pressure independent control valve for precise temperature control with digitally configurable, proportional actuator
  - Ball valve
  - Automatic air vent
- Installed in the below-roof unit for connection to the distribution network:
  - Pre-insulated corrugated pipelines through the connection module

#### 7.9 Pump control

Instead of the throttling circuit, a mixing or injection circuit can also be installed in the load circuit.

Please note the following:

- Not only the mixing valves but also the pumps in the load circuit are controlled directly by the unit control box.
- Terminals for wiring the mixing valves and the pumps in the load circuit are located in the unit control box.
- Install an automatic air vent in the roof unit at the highest point of the pipework.

- The return temperature sensor is pre-installed at the factory (TopVent® CC, SC: installation on site).
- Make sure that valves and pumps which meet the following requirements are provided on site.

**Requirements for mixing valves**

- Use 3-way mixing valves with the following flow characteristics:
  - Equal percentage control path
  - Linear bypass
- The valve authority must be  $\geq 0.5$ .
- The maximum run time of the valve actuator is 45 s.
- The valve actuator must be continuous, i.e. the stroke changes in proportion to the control voltage (0...10 VDC or 2...10 VDC).
- The valve actuator must be designed with a position response (0...10 VDC or 2...10 VDC).
- The maximum power consumption is 20 VA.
- Install the valve close to the unit (max. distance 2 m).

**Requirements for pumps**

- Voltage .....230 VAC
- Total current .....max. 4.0 A for all pumps (heating pump, cooling pump)

**Requirements on changeover valves**

Use changeover valves conforming to the following specification for heating and cooling in the 2-pipe system:

- 3-way changeover valves
- Supply voltage 24 V AC
- 1-wire control (0/24 V AC)
- Position response via limit switches (0°/90°)
- Power consumption:
  - max. 44 VA (TopTronic® C system control)
  - max. 13 VA (TopTronic® C system control for TopVent® C-SYS)

## 7.10 Roof frame

For easy installation of the TopVent® units in the roof, suitable roof frames are available as accessories. The roof frames consist of 4 load-bearing side walls made of galvanised sheet steel with fastening rails for the roof foil.

## 7.11 Protection hood

To protect the fresh air inlet from strong winds and snowfall, protection hoods are available as accessories for TopVent® supply air units.

## 8 Transport and installation



### Caution

Risk of injury from incorrect handling. Transport, assembly and installation work may only be performed by specialists. Observe safety and accident prevention regulations.

### 8.1 Scope of delivery

The scope of delivery includes:

- TopVent® unit, delivered in 2 parts on pallets (roof unit, below-roof unit)
- Accessories (transport eyes, installation material, temperature sensors)
- Optional components

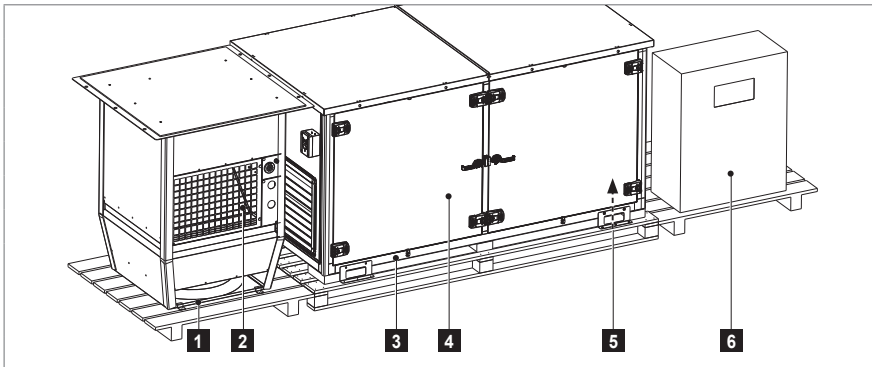

1 TopVent® below-roof unit

2 Extract air grille

3 TopVent® roof unit

4 Fan access door

5 Drawing pocket, type label

6 Zone control panel

Fig. 23: Delivery of the components on pallets

### Accessories

The following accessories are supplied separately:

- Transport eyes for lifting the below-roof unit (2 pieces per order, in the first roof unit, in the cardboard box behind the fan access door)
- Screws for assembling the unit (in the first roof unit, in the cardboard box behind the fan access door)
- Operating manual and CE declaration of conformity (1 x per order, in the first roof unit, in the cardboard box behind the fan access door)
- Spacer bars as transport protection for the roof unit (4 pieces per order, in the first roof unit)
- Wiring diagram (in the drawing pocket)
- Fresh air temperature sensor and room air temperature sensor (in the zone control panel)
- TopVent® CC, SC: Return temperature sensor (pre-wired at the factory, fastened near the coil)

### Options

The following optional components are supplied separately:

- Roof frame
- Additional room temperature sensors, combination sensor room air quality, temperature and humidity (in zone control panel)
- 2 collars for the air distribution box (behind the extract air grille)
- Protection hood

### Preparation

- Use a forklift with a sufficiently long fork to unload (at least 1.8 m).
- Check the consignment against the delivery documents and the order confirmation to ensure that it is complete. Report missing parts and any

damage immediately in writing.

- For deliveries of more than one unit:
  - Make sure that the correct unit components match up by checking the unit numbers.

### 8.2 Storage

If you do not install the unit immediately:

- Remove the packaging film to avoid water vapour condensation.
- Store the unit in a dry, dust-free room.
- Keep the storage temperature between  $-30\text{ }^{\circ}\text{C}$  and  $+50\text{ }^{\circ}\text{C}$ .
- Avoid too long storage periods. After a storage period of more than 1 year:
  - Check that the bearings of the fans move smoothly before installing the unit.

### 8.3 Requirements for the installation site

- Make sure that the roof has sufficient load-bearing capacity and that the roof frames correspond to the specifications in the design handbook.
- Position the units according to the system layout. Pay attention to the orientation of the units, the minimum and maximum distances and the position of the coil connections.
- All air inlet and air outlet openings must be freely accessible. The supply air jet must be free to spread out unhindered.
- The access doors in the roof unit must be freely accessible and there must be sufficient space for maintenance work.
- Make sure that supply air units draw in fresh air through the fresh air damper:
  - Not impaired by exhaust air openings, flues or the like
  - Roof frame protruding at least 300 mm from the roof

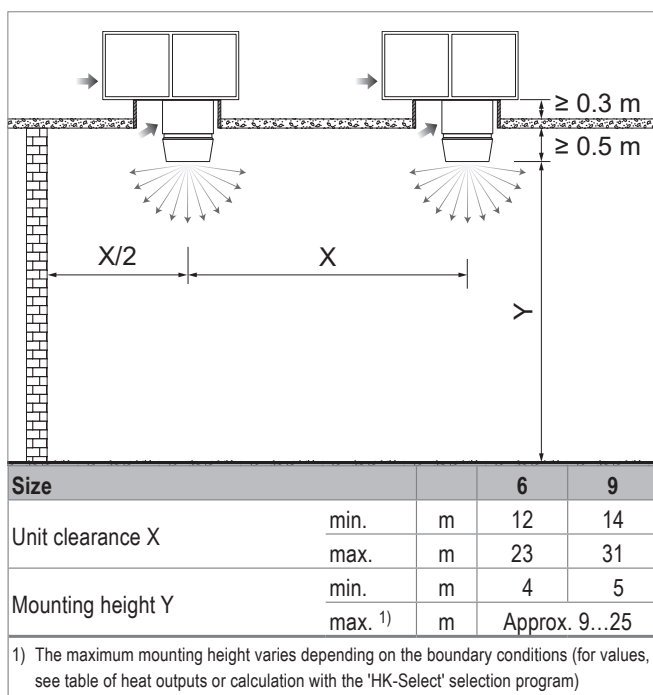

Fig. 24: Minimum and maximum distances

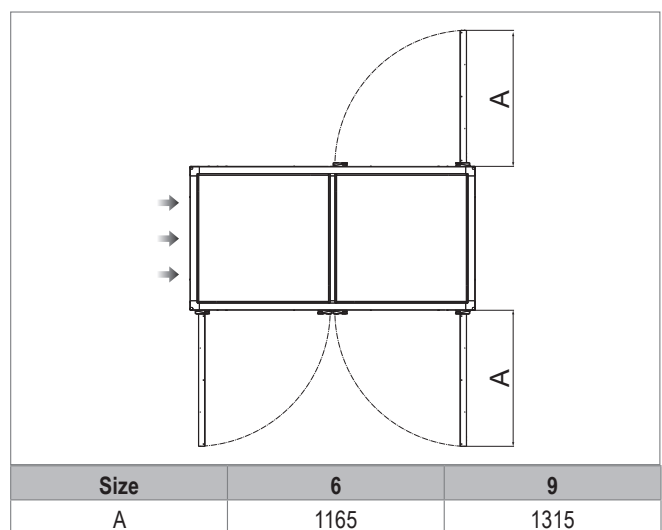

Fig. 25: Space requirements for opening the access doors (dimensions in mm)

## 8.4 Installation



### Caution

Risk of injury caused by falling load and improper handling.

During installation:

- Wear personal protective equipment.
- Do not stand under suspended loads.
- Use cranes or forklifts with sufficient load-bearing capacity.



### Caution

Provide suitable protective devices and make sure the units can be accessed easily. The roof of the TopVent® units cannot be walked on.

### Preparation

- The units are assembled from roof level. Make sure that the following items are on hand for the assembly:
  - Crane or helicopter for assembly on the roof
  - Ladder for screwing in the transport eyes
  - Lifting gear (lifting ropes at least 2 m in length for the below-roof unit, lifting straps at least 3 m in length for the roof unit)
  - Sealing compound for the roof frame (e.g. Sikaflex® 221)
  - Adhesive for securing screws (e.g. Loctite® 243, medium strength, soluble)
- Roof unit:
  - Remove the roof unit from the packaging film.
- Below-roof unit:
  - Remove the below-roof unit from the packaging film.
  - Remove the mounting bracket or wooden slats with which the below-roof unit is fixed to the pallet.



### Notice

For units without a pre-installed hydraulic assembly, it may be necessary, depending on the local conditions, to install the piping in the connection module even before the unit is mounted (see section 8.6).

- Roof frame:
  - Fasten the adjustment screws with nuts and lock washers in the roof frame.
  - Apply sealing compound to the roof frame.

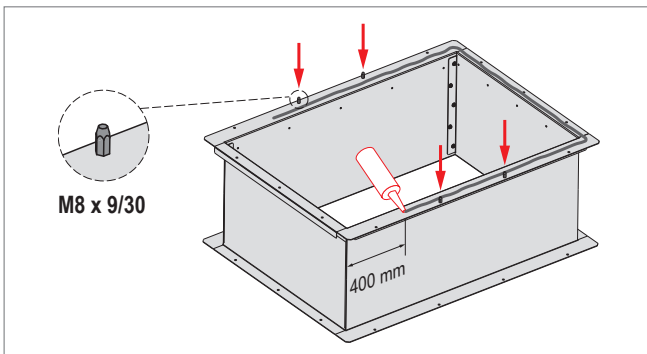
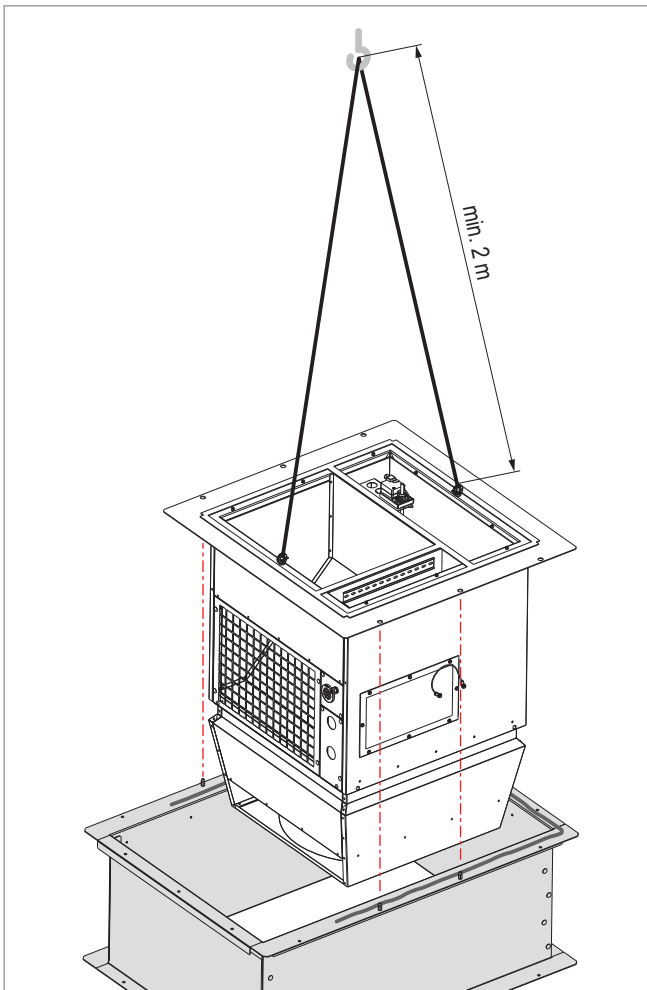

Fig. 26: Preparing the roof frame

**Installing the below-roof unit**

- Screw in the transport eyes into the connection module frame and attach the lifting gear.
  - Heed the minimum length of the lifting ropes (see Fig. 27).
- Transport the below-roof unit to the roof frame using a helicopter or crane.
- Turn the below-roof unit to the correct position.
- Hang the below-roof unit into the roof frame from above.
  - The adjustment screws on the roof frame support the correct positioning.
- Check the sealing strip on the connection module flange. Improve the seal if necessary.
- Remove the transport eyes.

**Fig. 27: Hanging the below-roof unit**

### Installing the roof unit

- Loosen the fixation of the lifting kit on the pallet.
- Attach the lifting gear (see Fig. 28).
  - Heed the minimum length of the lifting straps.
  - Protect the unit roof at the 4 upper corners with spacer bars that rest against the profile frame of the unit.
  - Pass the lifting straps through the lugs of the lifting kit.
- Apply sealing compound to the roof frame.
- Transport the roof unit onto the roof.
- Correctly position the roof unit over the below-roof unit and set it down.
  - The isolation switch of the roof unit and the extract air grille of the below-roof unit are located on the same side.
  - The adjustment screws on the roof frame support the correct positioning.
- Screw the roof unit to the roof frame:
  - Use the supplied M8 x 30 screws and washers.
  - Torque 20 Nm
  - Secure the screw connection using medium-strength, soluble adhesive (e.g. Loctite® 243).
- Remove the lifting kits:
  - Unscrew the lifting kits.
  - Keep the lifting kits for when disassembling the units at a later date at the end of their service life.
  - Remount the screws in the unit.

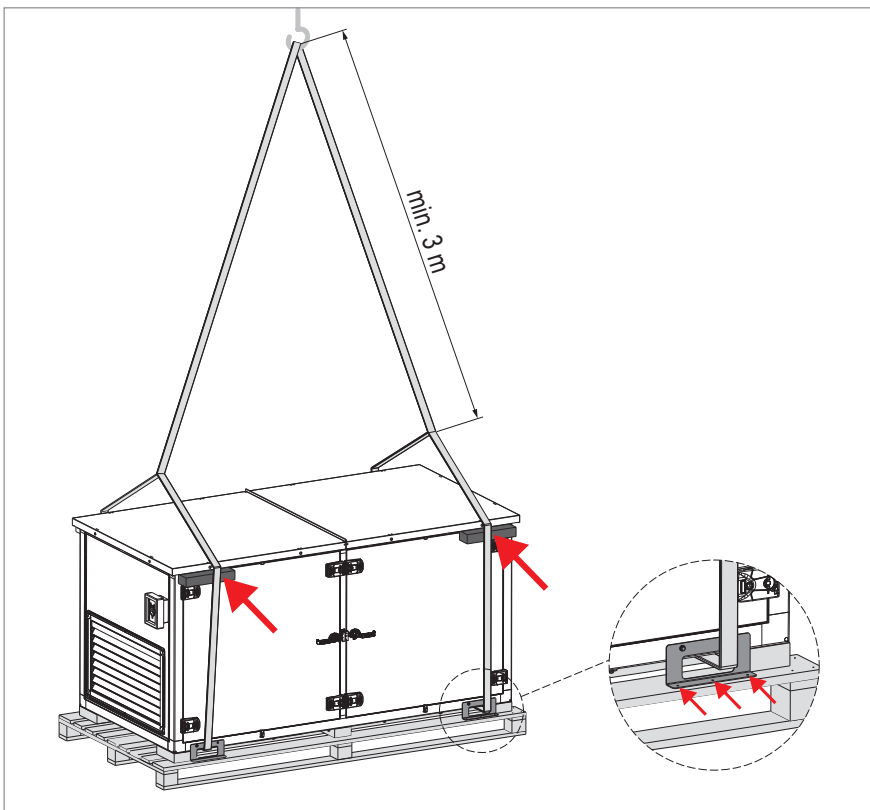
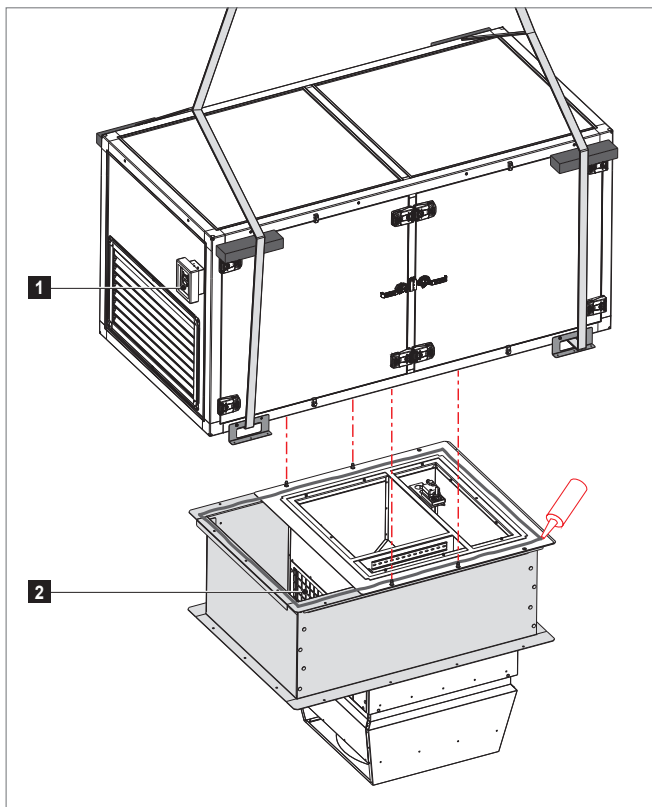

Fig. 28: Lifting the roof unit





- 1 Isolation switch
- 2 Extract air grille

Fig. 29: Installing the roof unit

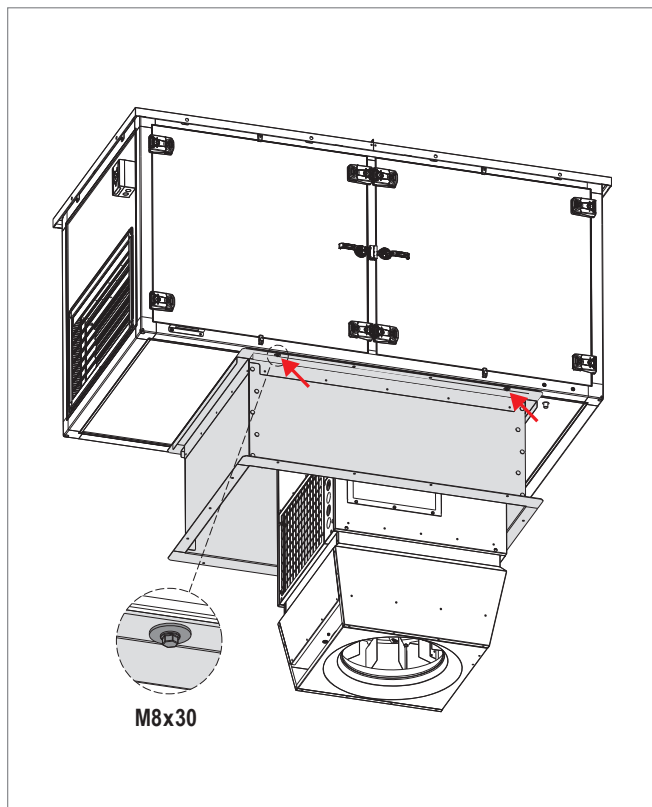

Fig. 31: Screw joint

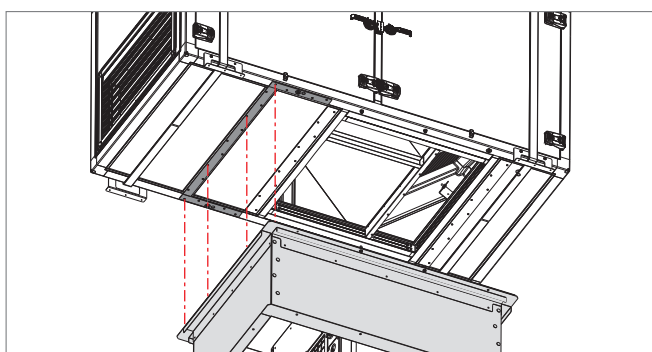

Fig. 30: Positioning on the roof frame

### Mounting the protection hood

The protective hood for the fresh air inlet (option) is supplied loose, consisting of 2 side plates and 2 cover plates. It must be fitted to the unit at the building site. The mounting material is provided. Proceed as follows:

- Screw the upper cover plate onto the two side plates.
  - Use the M4 x 20 countersunk screws with washers (4 x).
- Screw the assembly to the roof unit.
  - Use the 4.5 x 35 Spengler screws with washers (11 x).
- Screw on the front cover plate.
  - Use the M4 x 20 countersunk screws with washers (10 x).

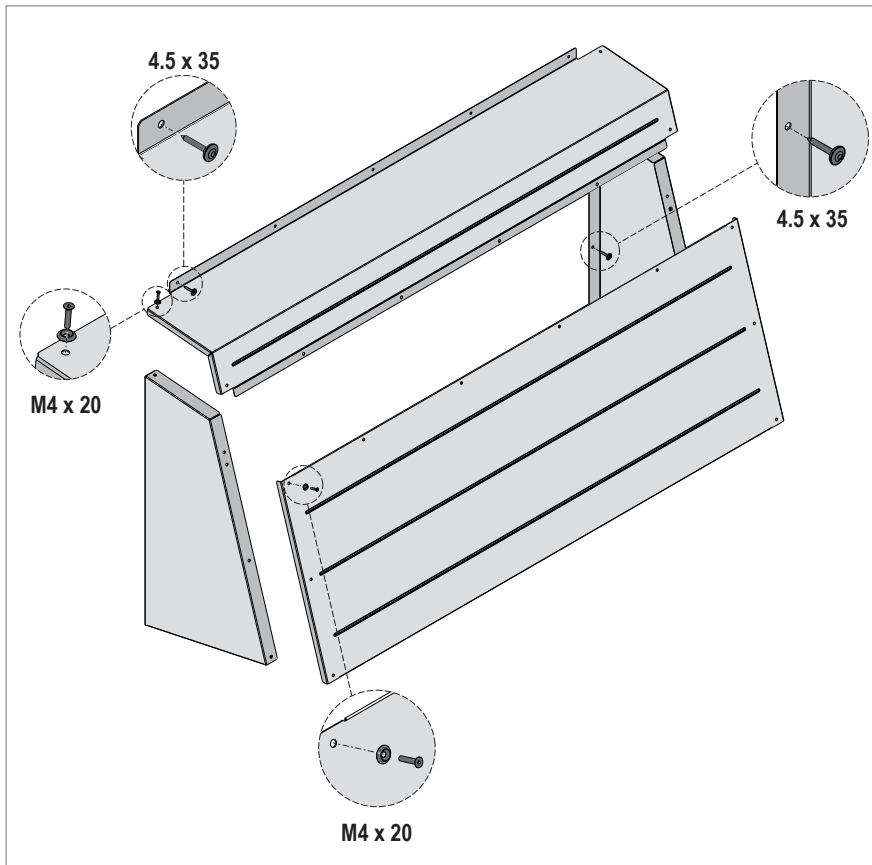

Fig. 33: Mounting the protection hood

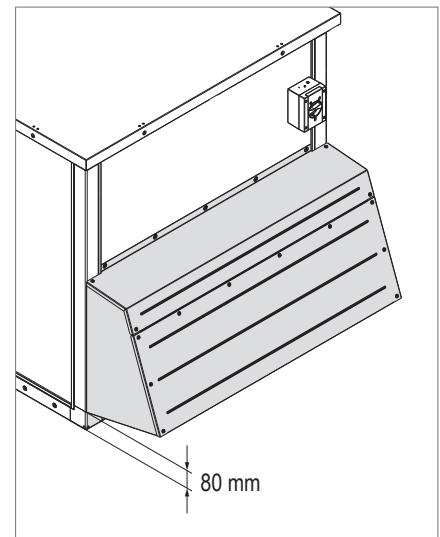

Fig. 32: Protective hood mounted on the roof unit

### 8.5 Connecting air ducts



**Attention**

Danger of damaging the units. The unit must not be subjected to the weight of the ducts. Suspend the ducts from the ceiling or support them on the floor.

**TopVent® units in the design without Air-Injector**

- Connect TopVent® units in the design without Air-Injector to a on-site air duct.

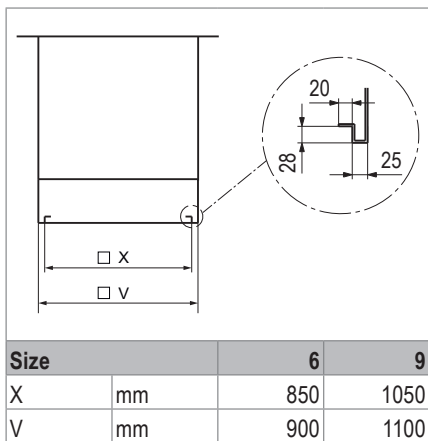

Table 34: Connection dimensions supply air duct (in mm)

**TopVent® units with air distribution box**

- Mount the collars on the air distribution box with 6 self-tapping screws each.
- Connect TopVent® units with air distribution box to a on-site air duct.

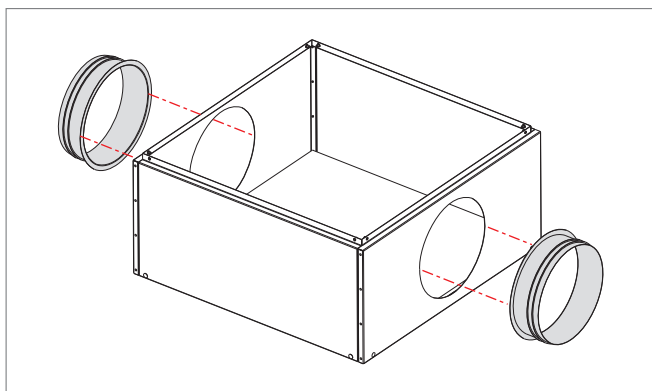

Fig. 34: Mounting the collars

## 8.6 Hydraulic installation

### Hydraulic installation of units without pre-installed hydraulic assembly

The connection points for the on-site pipe network are located in the roof unit, behind the hydraulic connection access door. The piping through the unit must be installed on site. We recommend the use of flexible corrugated pipes.



**Notice**

Install the piping through the connection module prior to mounting the unit in the roof if the installation lid in the connection module is impossible or difficult to access when installed.

Please note the following:

- Connect the heating or cooling coil in accordance with the hydraulic diagram.
- Install an automatic air vent in the roof unit at the highest point of the pipework.
- TopVent® CC, SC: Install the enclosed return temperature sensor:
  - Install the sensor on the return line, directly after the screw connection.
  - Attach the sensor with the clamping band.
  - Insulate the sensor.

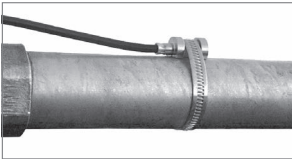

Fig. 36: Return temperature sensor

- Depending on local conditions, check whether compensators for linear expansion are required for the supply and return lines and/or articulated connections are required for the units.
- Insulate the hydraulic lines.
- Hydraulically balance the pipework for the the individual units within a control zone to ensure even distribution.



**Attention**

Danger of damaging the units. Do not fasten any loads to the coil, e.g. by means of the flow or return lines.



**Attention**

Danger of malfunctions. The condensate separator in cooling units only functions while the fan is running. No coolant must be allowed to circulate in the coil when the unit is switched off.

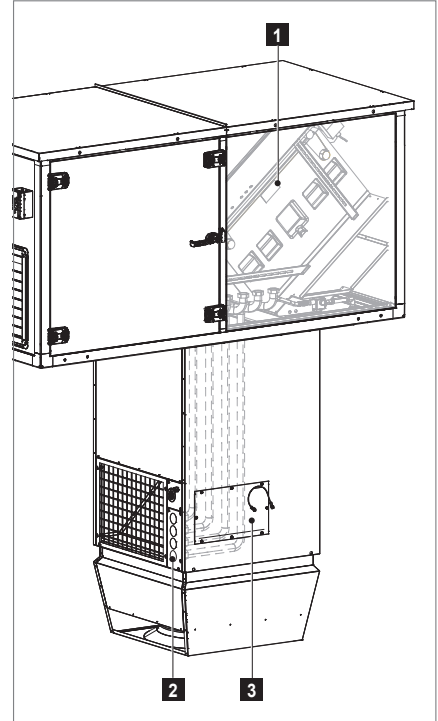

- 1 Hydraulic connection access door
- 2 Pipe outlets (Ø 55 mm)
- 3 Installation lid

Fig. 35: Hydraulic connection

**Hydraulic installation of units with hydraulic assembly throttling circuit (option)**

An assembly for the hydraulic throttling circuit is pre-installed in the unit. The connection points for the on-site pipe network are located on the connection module.

Please note the following:

- Connect the piping in the roof unit and in the below-roof unit.
- Connect the heating or cooling coil in accordance with the hydraulic diagram.
- Depending on local conditions, check whether compensators for linear expansion are required for the supply and return lines and/or articulated connections are required for the units.
- Insulate the hydraulic lines.



**Attention**

Danger of malfunctions. The condensate separator in cooling units only functions while the fan is running. No coolant must be allowed to circulate in the coil when the unit is switched off.

Setting the control valve

- Read the setting values for the control valve from the table below and set the required full-load flow rate on the valve:

Size		Flow in l/h													
6	DN 40	1000	1240	1530	1840	2200	2570	3020	3450	3960	4550	5200	5800	6500	
9	DN 50	2150	2640	3220	3790	4430	5150	5990	6870	7800	8790	9740	10600	11200	
Position		0.8	0.9	1.0	1.1	1.2	1.3	1.4	1.5	1.6	1.7	1.8	1.9	2.0	

Table 35: Flow at each setting and fully open valve plug

Setting	Isolating
<ul style="list-style-type: none"> <li>■ Remove the actuator.</li> <li>■ Turn the setting wheel to the desired value (e.g. 1.3).</li> </ul>	<ul style="list-style-type: none"> <li>■ Remove the actuator.</li> <li>■ Turn the setting wheel clockwise to stop (position 0 ±0.3).</li> </ul>

## 8.7 Electrical installation



### Caution

Danger of electric shocks. The electrical installation must only be carried out by a qualified electrician.

Please note the following:

- Observe all relevant regulations (e.g. EN 60204-1).
- Choose the dimensions of the cable cross sections in line with the applicable regulations.
- Route signal and bus lines separately from mains cables.
- Make sure the lightning protection system for the units or for the entire building is planned and carried out by professionals.
- Provide overload protection equipment on site in the mains connection line of the zone control panel.
- Carry out the electrical installation according to the wiring diagram.
- Secure all connections against working loose.
- When installing cables, observe the following points:
  - Fasten the cables in place with cable mounts and cable ties or with cable conduits/ducts.
  - Use blind rivets.
  - Drill holes with a maximum diameter of 5 mm Ø.
  - The maximum drilling depth is 10 mm. Use a drill bit with a depth stop.
  - The maximum load resulting from cable holders and cable guides is 10 kg.
  - All access panels must be easily removable.
  - Do not drill any holes in the connection module around the cable duct leading to the roof unit.

### TopVent® unit with TopTronic® C

- Connect the power supply to the unit control box.
- Connect the zone bus to the unit control box.
- Connect the unit frame with the foundation earth electrode and attach an earthing label.
- Connect the Air-Injector actuator.
  - The cable from the unit control box to the actuator is pre-installed in the roof unit.
- Wire up the Air-Injector actuator to the unit control box.
- Wire up the control valve(s) to the unit control box.



### Notice

In units with the 'hydraulic assembly' option, control valves are installed and pre-wired at the factory.

### TopVent® options

- Injection system:
  - Wire up the pump(s) and valve(s) to the unit connection box.
- TopVent® CH, CC, CHC:
  - Wire up the door contact to the unit control box.
- TopVent® SH, SC, SHC:
  - Wire up the signal for emergency shut-off (Forced off) to the unit control box.

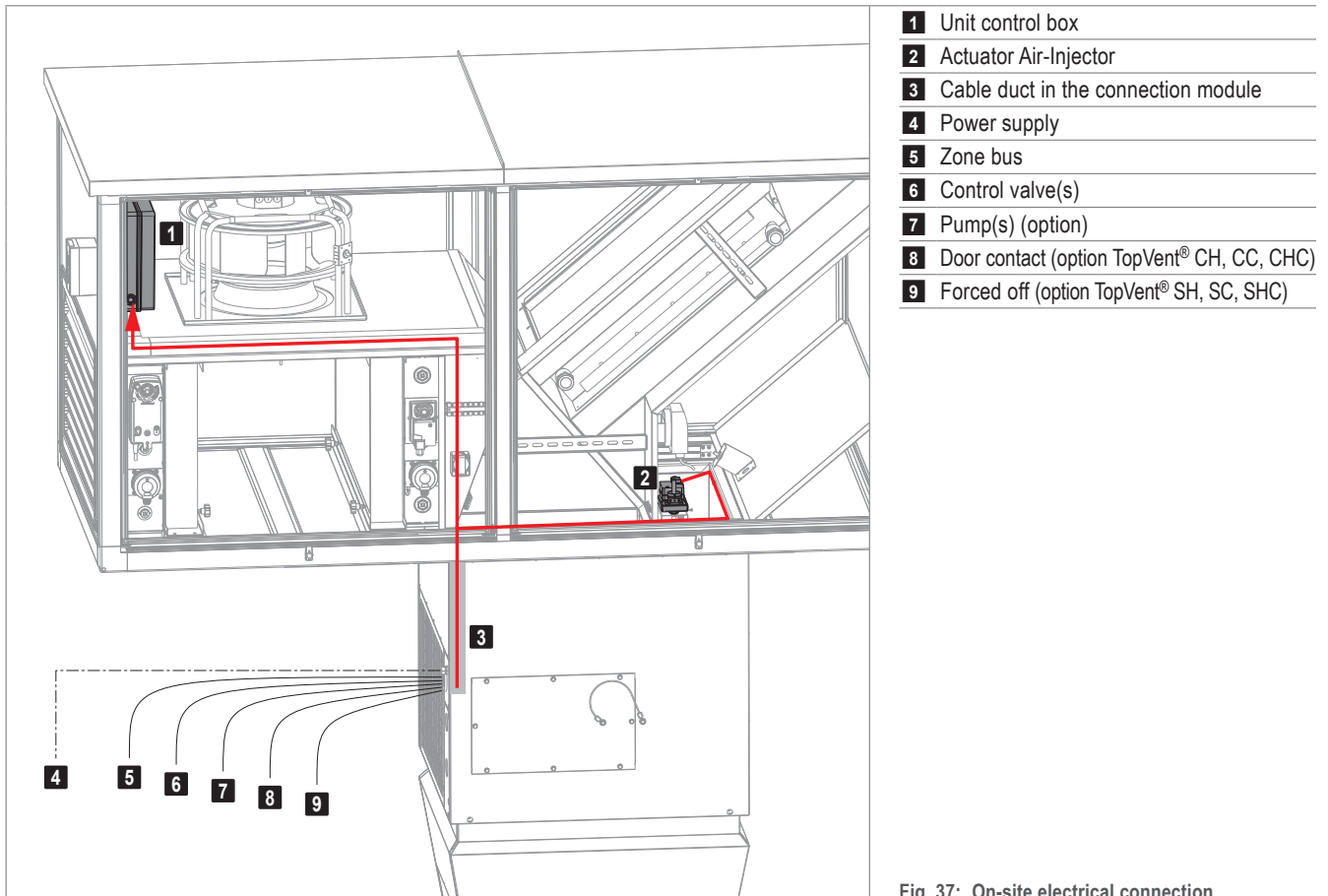

Fig. 37: On-site electrical connection

### Temperature sensors

The room air sensor and the fresh air temperature sensor are supplied loose in the control panel:

- Install the room air temperature sensor at a representative position in the occupied area at a height of about 1.5 m. The measured values must not be distorted by the presence of sources of heat or cold (machines, direct sunlight, windows, doors, etc.).
- Install the fresh air temperature sensor at least 3 m above the ground on a north-facing wall, so that it is protected from direct sunlight. Provide cover for the sensor and thermally insulate it from the building.

**TopVent® CH, CC with EasyTronic EC**

- Connect the power supply to the terminal box in the unit and to the EasyTronic EC.
- Lay the system bus according to the system layout.
- Wire up optional components according to the connection diagram (see Fig. 38 and Fig. 39).
- Lay the signal line for the differential pressure switch of the air filter to an on-site lamp or controller.
- TopVent® CC:
  - Lay the signal line for heating/cooling changeover to the EasyTronic EC.

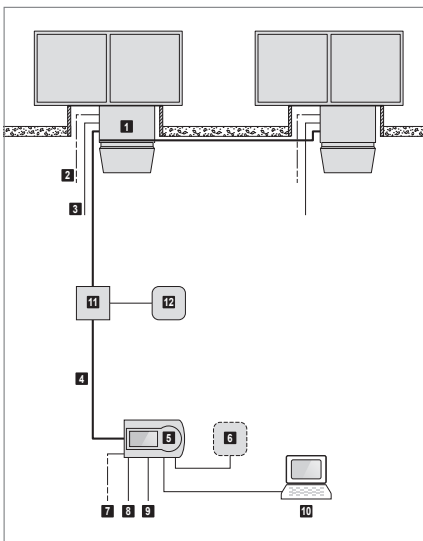

- 1** TopVent® CH, CC (max. 10)
- 2** Power supply for TopVent® CH, CC
- 3** Differential pressure switch air filter
- 4** System bus
- 5** EasyTronic EC
- 6** External room temperature sensor
- 7** Power supply for EasyTronic EC
- 8** Door contact
- 9** Heating/cooling changeover (TopVent® CC)
- 10** BMS connection via Modbus

Fig. 38: EasyTronic EC connection diagram without pump/valve control

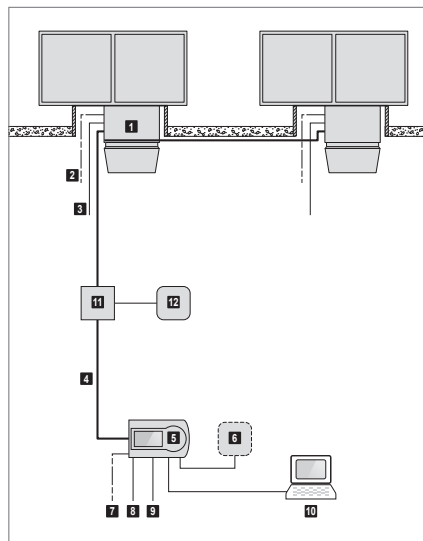

- 1** TopVent® CH, CC (max. 10)
- 2** Power supply for TopVent® CH, CC
- 3** Differential pressure switch air filter
- 4** System bus
- 5** EasyTronic EC
- 6** External room temperature sensor
- 7** Power supply for EasyTronic EC
- 8** Door contact
- 9** Heating/cooling changeover (TopVent® CC)
- 10** BMS connection via Modbus
- 11** Relay (on-site)
- 12** Pump/valve

Fig. 39: EasyTronic EC connection diagram with pump/valve control



**Terminal box design (TopVent® CH, CC)**

The following components are installed in the terminal box:

- Circuit board with all required electrical components as well as connection terminals for the following signals:
  - Input Enable fan
  - Input Control signal fan
  - Output Control signal next fan
  - Input Control signal actuator Air-Injector
  - Output Control signal next actuator Air-Injector
  - Output Feedback control signal Air-Injector
  - Output Error
- The following sensors and actuators in the unit are factory-wired:
  - Isolation switch
  - Fan
  - Supply air temperature sensor
- Options:
  - Lay the signal line for the differential pressure switch of the air filter to an on-site lamp or controller.

## 9 Operation

### 9.1 Initial commissioning



#### Attention

Risk of damage to property as a result of performing initial commissioning on your own authority. Initial commissioning must be performed by the manufacturer's customer service technicians.

#### Checklist to prepare for commissioning

- Mechanical installation
  - Indoor climate units
  - Zone control panels
  - Operator terminals
- Hydraulic installation
  - Indoor climate units (heating/cooling coil)
  - Complete heating/cooling circuit
  - Hydraulic balancing
  - Provision of the heating/cooling medium during commissioning
- Electrical installation
  - Power supply for indoor climate units, zone control panels, hydraulic pumps and valves
  - Wiring of control valve, pump, return temperature sensor, door contact, forced off to the unit control box
  - Laying of bus cables conforming to wiring diagram
  - Installation and wiring of all sensors (room temperature sensor, fresh air sensor, ...)
  - Wiring of external operator terminals
  - Wiring of external inputs and outputs
- Organisational matters
  - Access to all system components during commissioning (indoor climate units, operator terminals, valves, ...)
  - Provision of a suitable working platform
  - Organisation of commissioning and training (date, presence of all of the respective trade groups and of the operating personnel)

The unit is checked at the factory and preset according to the specifications on the type label.

### 9.2 Operation

The system runs fully automatically depending on the programmed operating times and temperature conditions.

- Observe the operating instructions for the control system.
- Check alarm displays daily.
- Correct changes to operating times in the programming accordingly.
- Ensure free air outlet and unhindered dispersion of the supply air.

## 10 Maintenance and repair



### Caution

Risk of injury from incorrect work. Maintenance work must be carried out by trained personnel.

### 10.1 Safety

Before performing any work on the unit:

- Turn the isolation switch on the unit to the 'Off' position and secure it against being switched back on.



### Caution

Danger of electric shocks. The unit controller and the service socket are still live.

- Wait at least 3 minutes after switching the unit off.



### Caution

The use of condensers can pose a danger of fatal injury from directly touching live parts even after the unit is switched off. Only open the access doors after waiting 3 minutes.



### Caution

Crushing hazard – the fresh air damper has a spring return actuator and closes automatically. Do not reach into the open damper.

- Observe the accident prevention regulations.
- Observe the particular dangers involved when working on electrical systems.
- When working in the unit, take precautions against unprotected, sharp metal edges.
- Immediately replace damaged or removed informational and warning signs.
- Following maintenance work, professionally reassemble all dismantled protective devices.
- Replacement parts must comply with the technical requirements of the unit manufacturer. Hoval recommends the use of original spare parts.

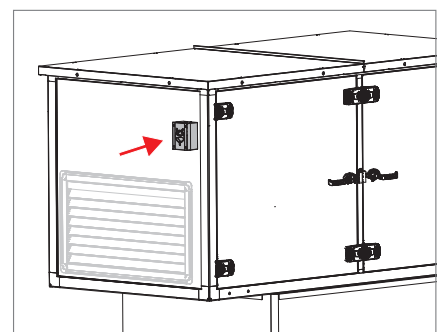

Fig. 40: Position of the isolation switch

## 10.2 Opening and closing access doors

### Opening

- Loosen the knobs at the top and bottom and turn them by 90°.
- Unlock the latch hinges with a 10 mm Allen key.
- Fold up the latches and turn them by 90°.
- Open the access door with the door handle until the door holder engages.
  - The door holder holds the door in position at an opening angle of 90°.

### Closing

- Check the earth cable and fix it again if necessary.
- Push up the locking pin to unlock the door holder.
- Close the access door with the door handle.
- Turn the latches by 90°, fold them down and press on until the lock engages.
- Turn the knobs at the top and bottom by 90°.

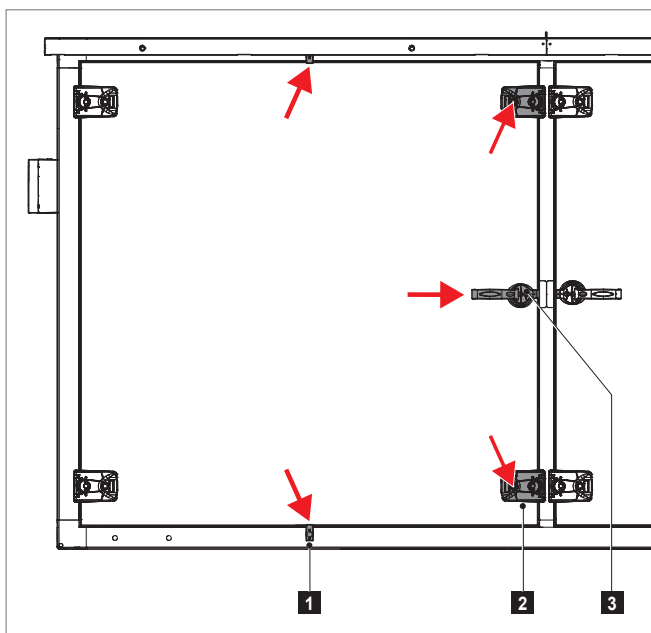

- 1** Knob
- 2** Latch hinge
- 3** Door handle

Fig. 41: Access door

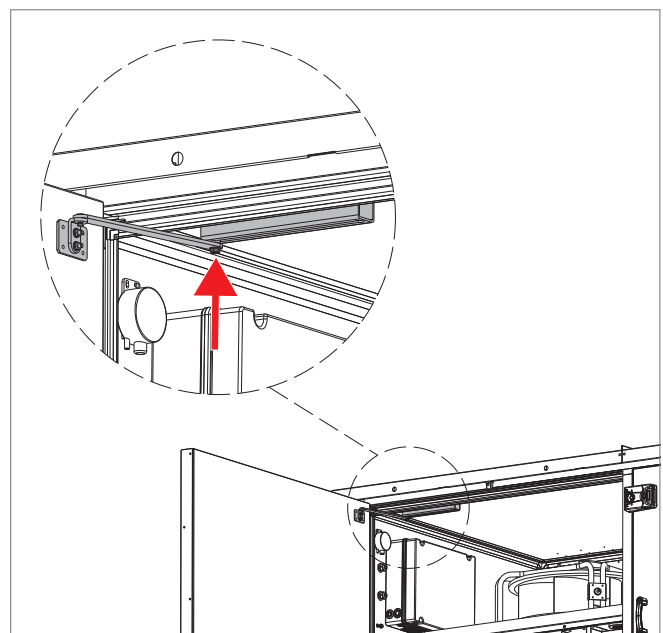

Fig. 42: Unlocking the door holder

### 10.3 Maintenance

#### Maintenance schedule

Activity	Procedure	Interval									
Clean unit	<ul style="list-style-type: none"> <li>■ Clean inside of TopVent® unit with vacuum cleaner.</li> <li>■ Remove the siphon, clean it and rinse the condensate drain.</li> </ul>	1 × annually									
Functional check	<ul style="list-style-type: none"> <li>■ Check function of the fan.</li> <li>■ Check fan motor for bearing damage.</li> <li>■ Check function of the actuators.</li> <li>■ Check function of the Air-Injector.</li> <li>■ Check function of the control system.</li> </ul>	1 × annually									
Filter change	<ul style="list-style-type: none"> <li>■ Renew air filter.</li> </ul> <table border="1" style="margin-left: 20px;"> <thead> <tr> <th>Fresh air / Extract air</th> <th>Filter class</th> <th>Mat. no.</th> </tr> </thead> <tbody> <tr> <td>Size 6</td> <td>ISO ePM<sub>1</sub> 55 %</td> <td>2079898</td> </tr> <tr> <td>Size 9</td> <td>ISO ePM<sub>1</sub> 55 %</td> <td>2080690</td> </tr> </tbody> </table>	Fresh air / Extract air	Filter class	Mat. no.	Size 6	ISO ePM <sub>1</sub> 55 %	2079898	Size 9	ISO ePM <sub>1</sub> 55 %	2080690	When the filter alarm is displayed, at least 1 × annually
Fresh air / Extract air	Filter class	Mat. no.									
Size 6	ISO ePM <sub>1</sub> 55 %	2079898									
Size 9	ISO ePM <sub>1</sub> 55 %	2080690									

Table 36: Maintenance schedule

#### Changing the filter



**Caution**

- Danger of hazardous emissions from damaged filters:
- Only hold the filters on the black filter frame.
  - Never touch the white filter medium.
  - Replace damaged filter elements immediately.

- Changing the air filter (fresh air/extract air):
  - Open the fan access door.
  - Loosen the star knobs (4 knobs per filter).
  - Remove the filter.
  - Insert the new filter.
  - Retighten the star knobs.
  - Close the fan access door.
- Dispose of the filters in accordance with local regulations.
  - The disposal of used filters depends on the contents.

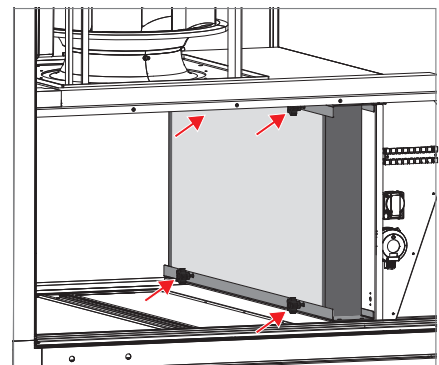

Fig. 43: Changing the filter

### 10.4 Repair

Please contact the manufacturer's customer service if needed.

#### Product service life

Component	Service life
EC motor of the fan	up to 40'000 hours depending on the application and environmental conditions

Table 37: Product service life

## 11 Dismantling



### Caution

- Risk of injury caused by falling load and improper handling.
- Wear protective equipment (fall protection, helmet, safety shoes).
  - Do not stand under suspended loads.
  - Use cranes or helicopters with sufficient load-bearing capacity.
  - Do not lift the two-part unit in one piece.

- Disconnect the power supply to the unit.
- Wait at least 3 minutes after switching the unit off.



### Caution

The use of condensers can pose a danger of fatal injury from directly touching live parts even after the unit is switched off. Only open the access doors after waiting 3 minutes.

- Drain the heating or cooling circuit.
- Dismantle all media connections.
- Disconnect the unit from any fastenings.
- Disconnect the screw connection between the roof unit and roof frame.
- Screw the lifting kits to the roof unit and attach the lifting gear.
- Remove the roof unit.
- Screw in the transport eyes into the connection module frame and attach the lifting gear.
- Remove the below-roof unit.

## 12 Disposal

- Recycle metal components.
- Recycle plastic parts.
- Dispose of electric and electronic parts via hazardous waste.
- Dispose of oil-fouled parts in accordance with local regulations.
- Dispose of the filters in accordance with local regulations.
  - The filters are fully incinerable; the disposal of used filters depends on the contents.

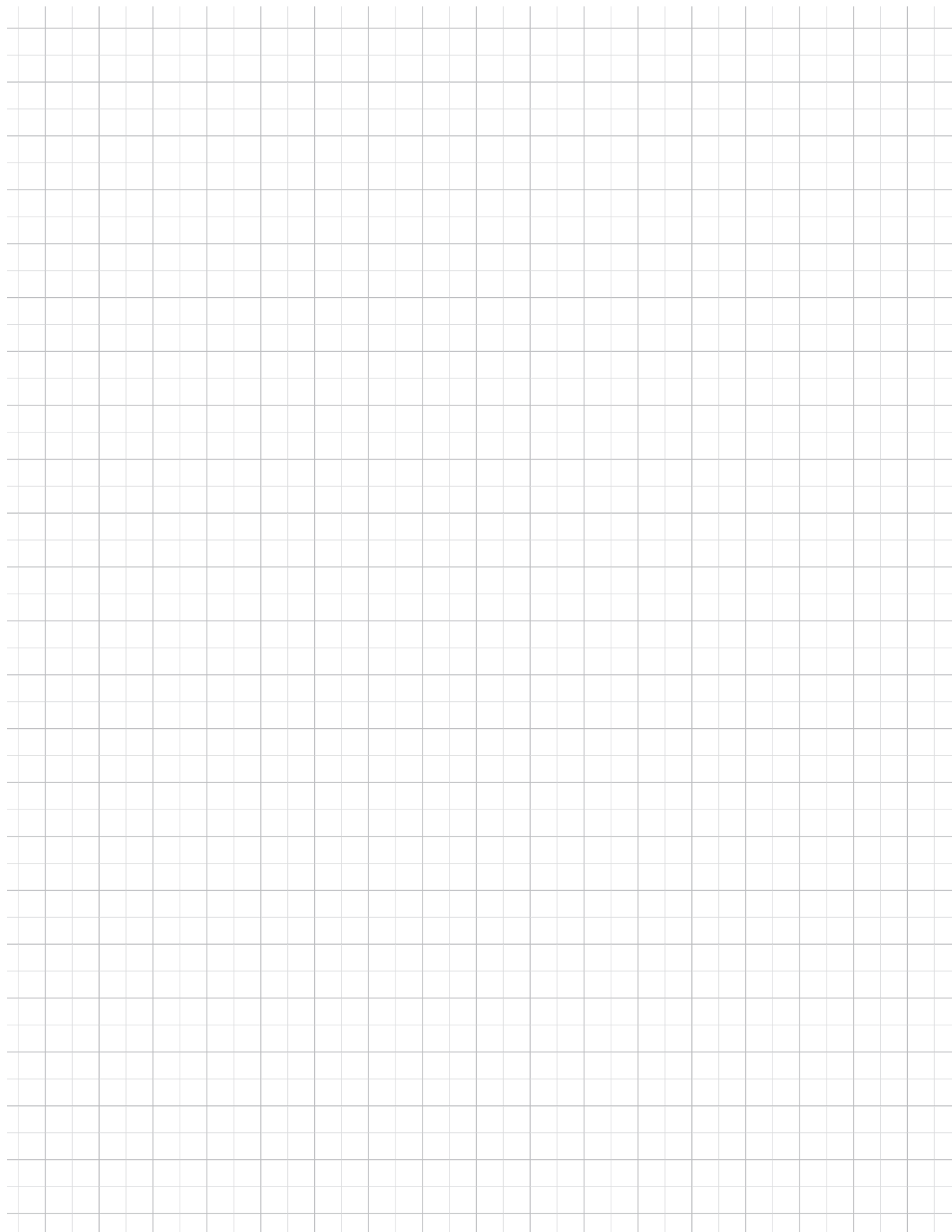

**International**

Hoval Aktiengesellschaft  
9490 Vaduz  
Liechtenstein  
Tel. +423 399 24 00  
info.klimatechnik@hoval.com  
www.hoval.com

**United Kingdom**

Hoval Ltd.  
Northgate, Newark  
Notts  
NG24 1JN  
Tel. 01636 672711  
hova@hova.co.uk  
www.hova.co.uk